

J. MOORE.
Reversible Latch.

2 Sheets--Sheet 1.

No. 166,129.

Patented July 27, 1875.

Fig. 1.

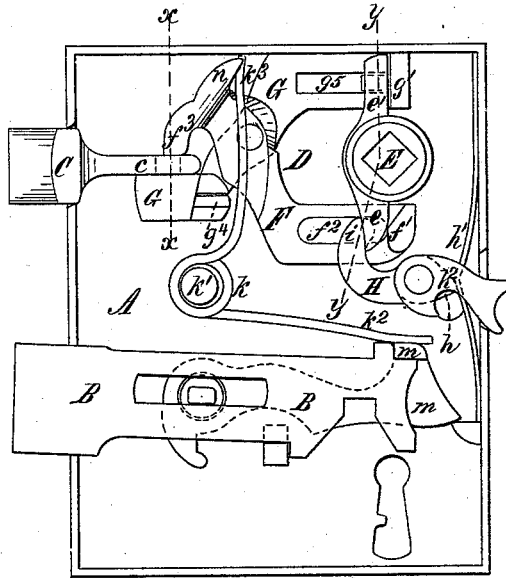
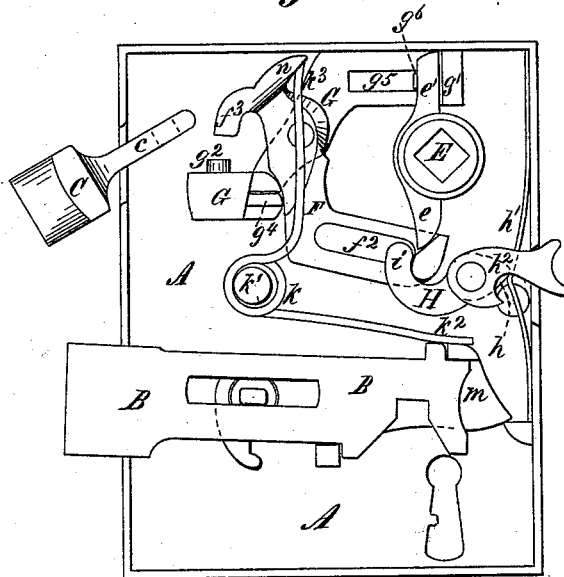

Fig. 2.



Witnesses:
E. H. Williams
Geo. H. Mott

Inventor:
John Moore
Per Edw. C. Secomb
att.

J. MOORE.
Reversible Latch.

No. 166,129.

Patented July 27, 1875.

Fig. 3.

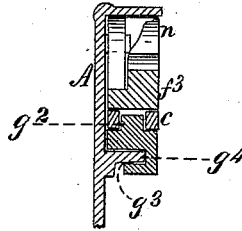

Fig. 4.

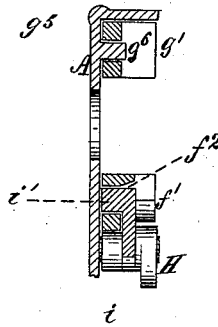
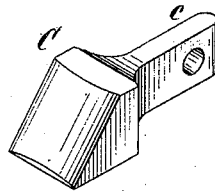

Fig. 5.



Witnesses:
E. H. Williams
Geo. H. Miatt

Inventor:
John Moore
Per Edw. C. Quincy
att'y

UNITED STATES PATENT OFFICE.

JOHN MOORE, OF BROOKLYN, E. D., NEW YORK.

IMPROVEMENT IN REVERSIBLE LATCHES.

Specification forming part of Letters Patent No. **166,129**, dated July 27, 1875; application filed July 13, 1875.

To all whom it may concern:

Be it known that I, JOHN MOORE, of Brooklyn, Eastern District, New York, have invented a certain Improvement in Reversible Locks, of which the following is a specification:

My improvement relates to that class of reversible locks in which the latch is capable of detachment and reversal without removing any part of the casing of the lock; and my invention consists in the peculiar construction and organization of the parts of the lock which operate the latch, primarily, in a jointed horseshoe, so called, one joint of which slides back and forth upon suitable guides in obedience to the motion of the knob, and is provided with a projecting pin for engaging and carrying the latch. The other joint of the horseshoe is pivoted to the sliding joint, and slides with it. After the latch has been hooked on the pin which holds it, the pivoted arm of the horseshoe is thrown up by a lever, and its forward end nips the latch-tail on the side opposite the seat to which it is pivoted, and securely holds the latch-tail upon its pin. This structure, which takes the place of the so-called horseshoe or forked link for transmitting the motion of the knob to the latch, constitutes, in fact, a pair of nippers. The end of the pivoted lever which engages the latch-tail resembles in appearance the hammer of a gun-lock, and is pressed against the latch-tail by the spring, which operates to give the latch its outward movement after it has been withdrawn into the lock by the turning of the knob in the usual way. When the pivoted lever has nipped the latch-tail the rear arms of the sliding joint and the pivoted joint stand parallel to each other, and present the appearance of the ordinary horseshoe or forked slide-piece, and their inner extremities are provided with laterally-projecting lugs to engage the horns on the hub of the knob-spindle. I operate the pivoted joint of my horseshoe by a pivoted lever, one end of which projects slightly through the end wall of the lock-case, while the other end engages a slot in the pivoted joint of my horseshoe.

The accompanying drawings are as follows: Figure 1 is a view of the interior of the lock with casing removed, showing the parts in position for operation. Fig. 2 is a similar view,

showing the pivoted lever thrown back—or, in other words, the nippers unclosed, and showing the latch detached from the latch-tail pin. Fig. 3 is a section through the line *xx* on Fig. 1, showing the rail for guiding the horseshoe, the lip of the horseshoe, and the pin for engaging the latch-tail, a cross-section of the latch-tail, and a portion of the pivoted lever. Fig. 4 is a section through the line *yy* on Fig. 1, the hub being removed. Fig. 5 is a perspective view of the latch.

Referring to the drawings, A represents the case of a lock, containing the usual bolt B and the latch C, the latter carried by the horseshoe slide-piece D. The hub E of the knob-spindle is provided with the two horns *e* and *e'* for operating the horseshoe-slide by engaging the end lugs *f*¹ and *g*¹, respectively, projecting from the inner ends of the joints F and G of the horseshoe, the horn *e* being rounded to accommodate the sweep of the pivoted joint F. H is a pivoted lever for operating the pivoted joint F of the horseshoe. The hub of this lever H is provided with a radially-projecting cam, *h*, which rides over the crown of the flat spring *h*¹. It will be seen that the tendency of this spring is to throw the lever H either way from its center of motion. When the parts are in the position shown in Fig. 1 the force exerted by the spring *h*¹ upon the cam *h* is transmitted through the inner end *i* of the lever H to the pin *i'*, which engages the slot *f*² in the pivoted joint of the horseshoe, and thrusts the end of the pivoted joint of the horseshoe toward the hub, thus closing the jaw or other end *f*³ of the pivoted joint upon the latch-tail *c*. The latch-tail is perforated to admit the pin *g*² projecting vertically from the forward end of the sliding joint G. The forward end of the sliding joint G is provided with the groove *g*³ for embracing the guide-rail *g*⁴, which is affixed to the wall of the lock-chamber. The inner end of the sliding joint G is provided with the slot *g*⁵, which engages the guide-pin *g*⁶, also affixed to the shell of the lock-case. The mainspring *k* of the lock is coiled spirally upon the pin *k*¹, and one end *k*² of the wire spring presses against the bolt-tumbler *m*, while the opposite end *k*³ of the wire spring engages the end of a rearward projection; *n*, on the forward end of the piv-

oted joint of the horseshoe. The lever H is concentrically notched at h^2 , for the purpose of engaging one of the screws by which the lock is attached, so that the reversing mechanism cannot be operated without the withdrawal of the screw in question. It will be seen that when the lever H is thus fixed in position, the pin i' acts as a guide for engaging the slot f^2 in the pivoted joint F. The latch C is at its forward end of the usual form, and occupies the slot in the end wall of the lock-chamber, in the usual manner. The inner part of the latch, which I call the latch-tail, consists of the narrow central blade c , and it will be seen that when the pivoted joint of the horseshoe is thrown backward, as shown in Fig. 2, the latch C may be extricated from the pin on the sliding joint of the horseshoe by pressing sideways that part of the latch which projects outside of the end of the lock. The latch C may then be withdrawn and reversed, and be again affixed to the horseshoe by slipping the tail on the pin, and closing the pivoted joint upon it, as before.

I claim as my invention in a reversible lock—

1. The jointed sliding link or horseshoe, in combination with the tail-piece of a detachable latch and the horns of a knob-shaft hub, substantially as shown and described.

2. The combination of the pivoted joint F of the horseshoe with the lever H, projecting through the shell of the lock, substantially as and for the purposes set forth.

3. The combination of the pivoted joint F, provided with the slot f^2 , and the movable guide-pin i' , affixed to the inner end of the lever H, with the notch h^2 , and a screw passing through the lock, for the purpose of maintaining the pin i' in suitable position to act as a guide for the horseshoe in its reciprocating movement, substantially as shown and described.

JOHN MOORE.

Witnesses:

E. H. WILLIAMS,
GEO. W. MIATT.