

T. NOONAN.
Spring-Bottom for Chairs, &c.

No. 166,133.

Patented July 27, 1875.

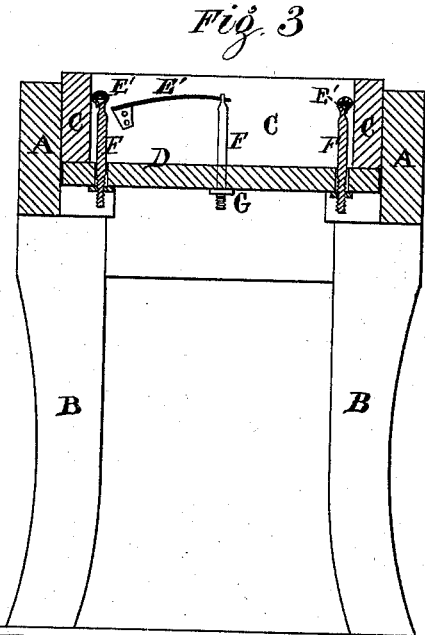
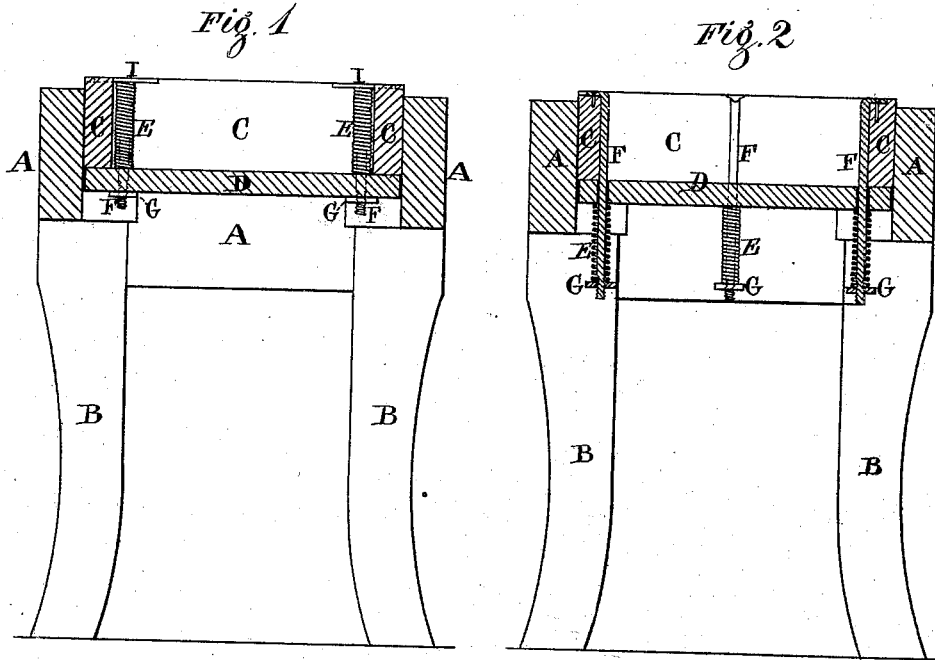

Witnesses
Sam^l. M. Barton
J. J. Donahue

Inventor
Timothy Noonan
by his atty
Carr & Wright

UNITED STATES PATENT OFFICE.

TIMOTHY NOONAN, OF BOSTON, MASSACHUSETTS.

IMPROVEMENT IN SPRING-BOTTOMS FOR CHAIRS.

Specification forming part of Letters Patent No. **166,133**, dated July 27, 1875; application filed March 16, 1874.

To all whom it may concern:

Be it known that I, TIMOTHY NOONAN, of Boston, in the county of Suffolk and State of Massachusetts, have invented certain Improvements in Spring-Bottoms for Chairs, Sofas, &c., of which the following is a specification:

Figures 1, 2, and 3 of the accompanying drawings are central longitudinal vertical sections of the bottom frame of a chair, showing different methods of applying my improvement.

The object of the present invention is to provide a movable bottom or support to sustain the springs and filling of a chair, lounge, sofa, or other seat, and allow it to yield to the pressure exerted thereon when occupied, without subjecting the springs and upholstery to the injury occasioned by their sudden concussion when hastily sat upon, or constant pressure from continual use against an unyielding bottom, as has heretofore been the case in upholstered spring-seats as ordinarily constructed with stationary wooden bottoms; and to this end my invention consists in an adjustable bottom connected to the upholstered frame of a chair, lounge, sofa, &c., by springs and rods or stems suitably arranged to form a yielding seat for the seat-springs and filling, as I will now proceed to describe.

In the drawings, A represents the bottom frame of a chair, lounge, sofa, &c., supported by legs B, and having properly held within its upper portion an inner frame, C, to receive the springs and upholstery of the chair or other seat, the bottom of which upholstery and springs rests on a movable bottom or support, D, which, in its normal position, is held so as to abut against the bottom of the frame C by spiral or other springs, E, arranged on and attached at one end to rods or stems F. The rods or stems F may be located, as in Fig. 1, in each corner of the interior of the frame C, extending through the bottom D, to which each is held by a screw-nut, G, turning on screw-threads formed on the lower end of the rods; and impinging against the under side of the bottom D. One end of each spring E is attached to each rod F above the bottom D, and the other end of the spring is attached to a metal or other plate, I, extending across

each corner of the top of the inner frame C, or the springs may be otherwise suitably held; or rods F may be located, as in Fig. 2, on each side of the frame C at the center, and flanged on the top laterally, or otherwise arranged to be readily secured to the frame C. Each of these rods F extends through, and at a sufficient distance below, the bottom D, to receive a spiral spring, E, which at the top bears against the under side of the bottom D, and at the bottom is attached to the rod F, and finds a seat upon the top of a screw-nut, G, that turns on screw-threads formed on the lower end of the rod F; or a lever-spring, E', Fig. 3, flanged at one end, or otherwise formed to be properly secured to the interior of each side of the upper portion of the frame C, and connected at the other end with a vertical rod, F, that extends through in the center of each side of the bottom D, to which it is held by a screw-nut, G, turning on screw-threads formed on the lower end of the rod F, may be used for sustaining and operating the bottom D; or any other arrangement of springs that may be preferred may be employed to sustain and allow the up-and-down movement of the bottom D.

By means of the screw-nuts G turning on their several rods, the tension of the several springs F is regulated.

By the above description, reference being had to the drawings, it will readily be seen that, when pressure is exerted on the seat, it causes the seat-springs and filling to bear upon the bottom D, which, by the action of the spring F, yields sufficiently to allow an easy contraction of the seat-springs, which are thus prevented from any injury heretofore liable to occur when pressed against a stationary unyielding bottom as ordinarily constructed.

Moreover, when the pressure from the seat is removed, the seat-springs and filling are, by the lifting of the bottom by the reaction of the springs F, readily and effectively readjusted to, and retained in, their original position, and the sagging of the seat, heretofore occasioned by the non-recuperative action of the upholstery and springs when subjected to much or injurious wear, is prevented.

Having thus fully described my improve-

ments, what I claim as my invention, and desire to have secured to me by Letters Patent, is—

In a chair-bottom, the combination of stationary frames A C, yielding bottom board D, adjustable rods F, and spiral springs E, as and for the purpose set forth.

In testimony whereof I have signed my name to this specification in the presence of two subscribing witnesses.

TIMOTHY NOONAN.

Witnesses:

CARROLL D. WRIGHT,

SAML. M. BARTON.