

C. D. & E. D. READ. 3 Sheets--Sheet 1.
Corn-Sheller.

No. 166,142.

Patented July 27, 1875.

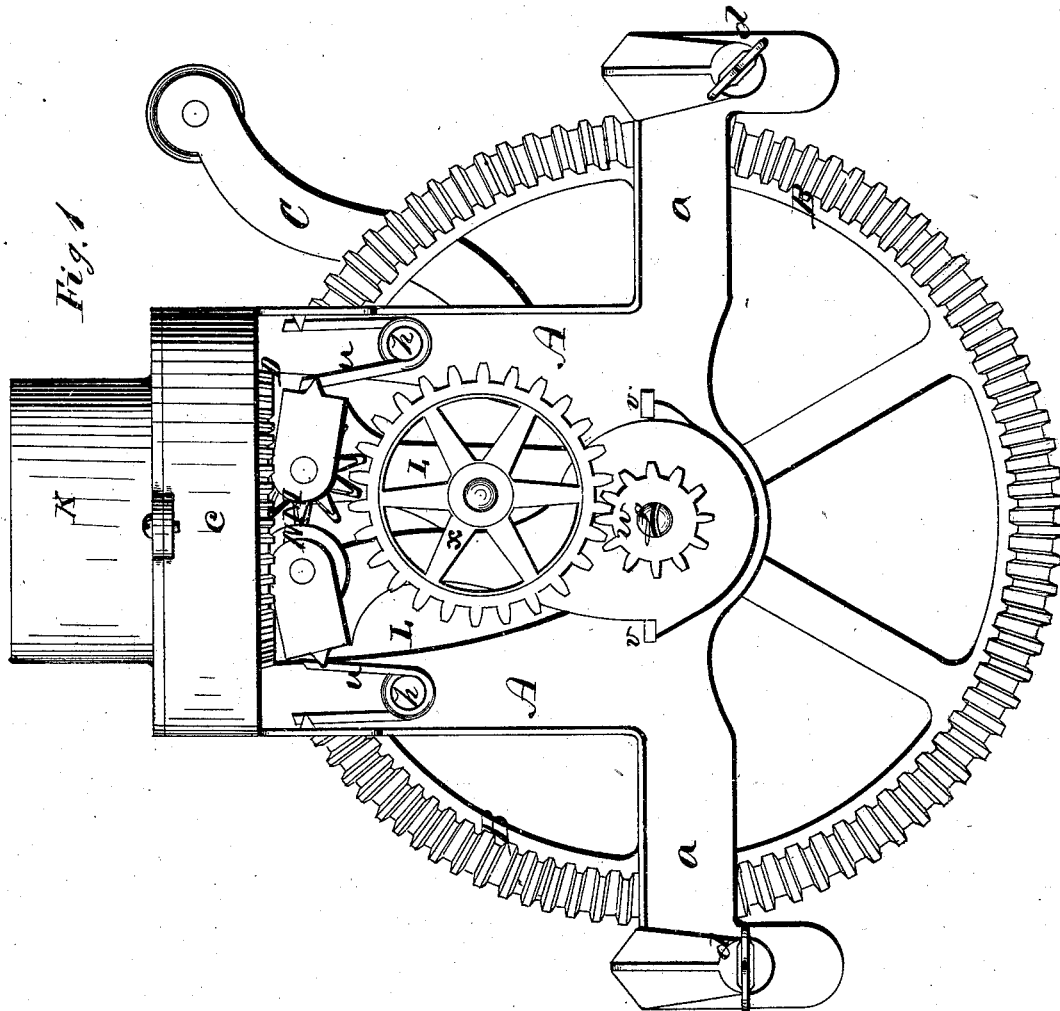

WITNESSES
C. M. Gallagher,
By
C. Clarence Poole

INVENTORS
Calvin S. Read,
Ellis S. Read,
J. S. Brown, their Attorney

C. D. & E. D. READ.
Corn-Sheller.

No. 166,142.

Patented July 27, 1875.

Fig. 2.

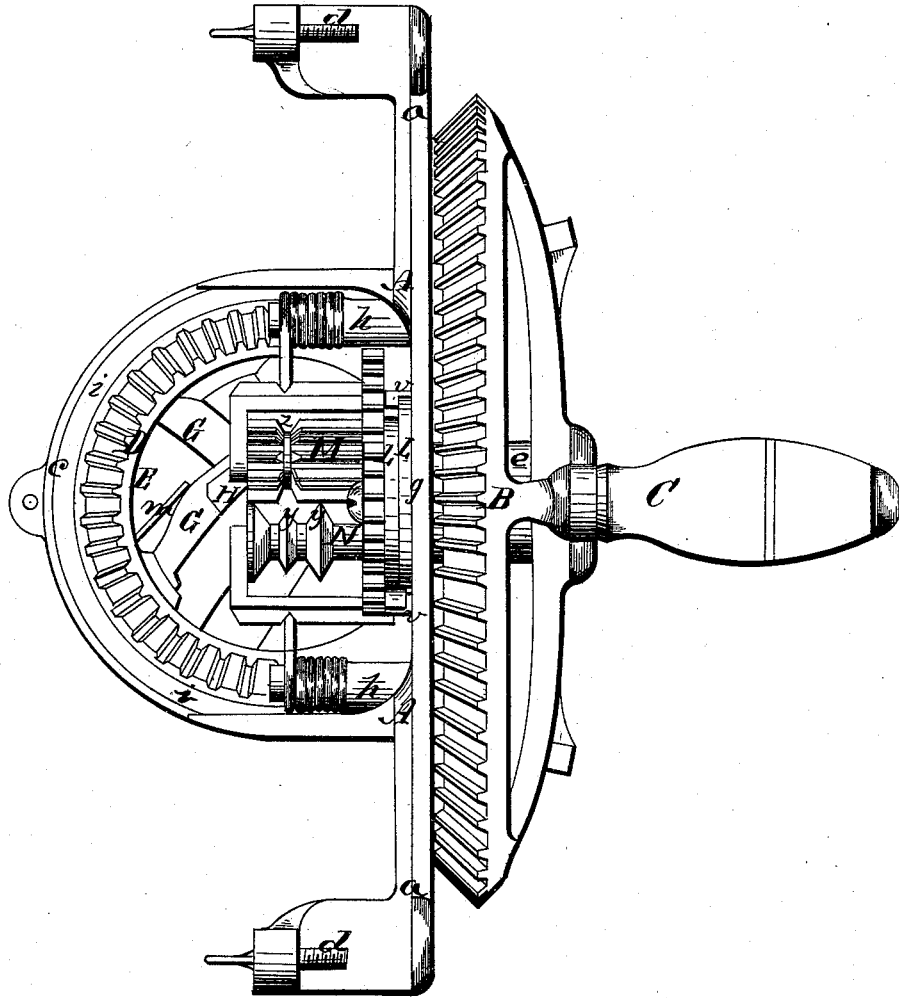

WITNESSES
C. M. Gallaher.
C. Clarence Poole By

INVENTORS,
Calvin D. Read,
Ellis D. Read,
J. S. Brown, their Attorney

C. D. & E. D. READ.
Corn-Sheller.

No. 166,142.

Patented July 27, 1875.

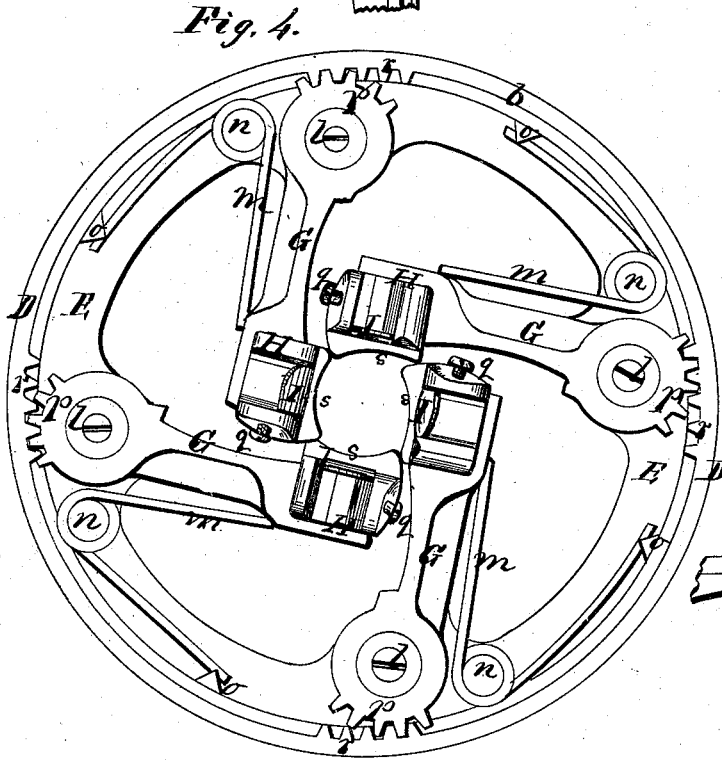
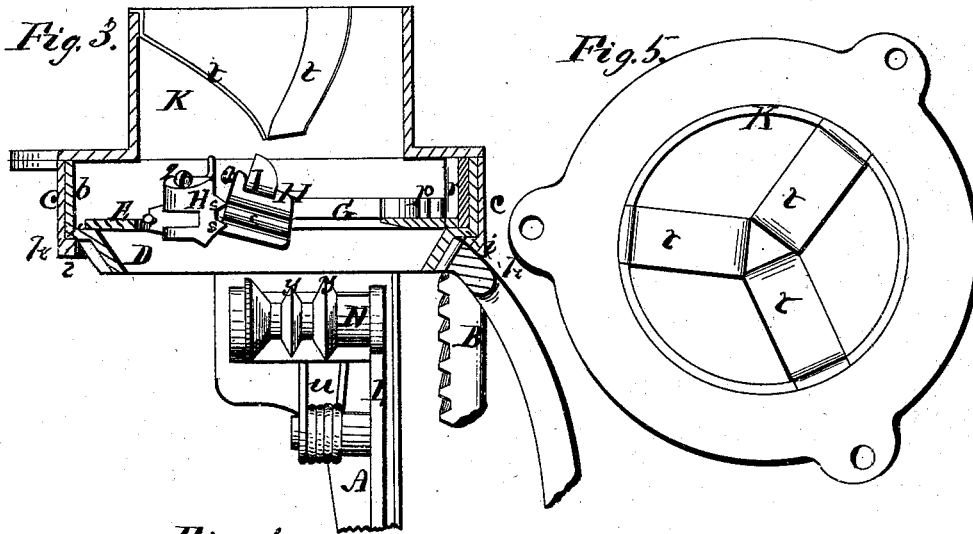

Fig. 6.



Fig. 7.



WITNESSES
C. McCallahan

C. Clarence Poole

By

INVENTORS,

Calvin D. Read,
Ellis S. Read,

J. S. Brown, their Attorney

UNITED STATES PATENT OFFICE.

CALVIN D. READ AND ELLIS D. READ, OF AYER, ASSIGNORS OF ONE-THIRD THEIR RIGHT TO JAMES GOODRICH, OF FITCHBURG, MASSACHUSETTS.

IMPROVEMENT IN CORN-SHELLERS.

Specification forming part of Letters Patent No. **166,142**, dated July 27, 1875; application filed April 7, 1875.

To all whom it may concern :

Be it known that we, CALVIN D. READ and ELLIS D. READ, of Ayer, in the county of Middlesex and State of Massachusetts, have invented an Improved Machine for Shelling and Cutting Green Corn, and for Shelling Dry Corn; and we do hereby declare that the following is a full and exact description thereof, reference being had to the accompanying drawings making part of this specification—

Figure 1 being a side view of the machine; Fig. 2, a view of the same looking upward; Fig. 3, a central vertical section of the upper part of the same; Fig. 4, a top view of the ring part of the frame and of the working parts mounted therein; Fig. 5, a top view of the feeding-hopper and of the guide-springs located therein; Figs. 6 and 7, views of parts detached.

Like letters designate corresponding parts in all of the figures.

The special purpose of our invention is to cut green corn on, and shell it from the cob, for use in canning establishments, and in hotels, eating-houses, and dwelling-houses.

The machine also is applicable to the ordinary purpose of shelling dry corn.

The nature of our invention consists in various improvements in the construction and functional parts of the machine; and we will set forth the said improvements one by one in succession.

First, in the construction of the frame, on and within which the several working parts of the machine are mounted. The body A thereof consists of an upright plate of cast-iron, with two lateral flange-arms, *a a*, for attaching the machine to the edge of a box or other suitable support, and with a lateral overhanging ring or short cylinder, *c*, at the top, within which are arranged the principal shelling parts; all of this frame being cast in one piece. Upon top of this ring part *c* is secured a short cylinder, K, of less diameter, through which the ears of corn are fed one by one. The flange-arms *a a* are provided with clamping-fingers and with thumb-screws *d d* for securing the machine to the support. The frame also has a hollow projecting bearing, *e*,

in which the driving-wheel shaft *f* turns. Other projections or studs, *g* and *h h*, are cast therewith, on which other parts of the machine are mounted. The driving-wheel B has a crank, C, if the machine is to be operated by hand; or it has a pulley if it is to be turned by power. The driving-wheel B gears into a bevel pinion, D, which bears the actual corn cutting and shelling parts of the machine. It is a ring-pinion, having no shaft or radial arms, and it is fitted and turns within the ring-projection *c* of the frame, as clearly shown in Figs. 3 and 4, there being an inner ledge, *i*, on the ring-projection, on which the ring-pinion rests. Thus all the interior space in this pinion is left free to receive the corn cutting and shelling parts, and to allow them to operate unimpeded. These parts form another distinctive feature of our invention, substantially as follows: Inside of an upper cylindrical part, *b*, of the ring pinion or gear D, and resting on a ledge, *k*, thereof, is located a separate movable ring-plate, E, on which project upward pivot-studs *l l l l*. On these pivots, respectively, are journaled inwardly-projecting arms G G G G, formed and arranged substantially as shown in Fig. 4; the inner ends thereof reaching inward so as to meet or nearly meet one another, and to surround a small nearly circular central space, down through which the ears of corn are driven for cutting and shelling the corn. These arms are pressed toward one another and the central space between them, for action upon the ears of corn, by means of springs *m m m m*, attached by studs *n n n n* to the ring-plate, and bearing at their outer ends against notched lugs *o o o o*; or any equivalent arrangement of springs may be employed; and, in order that these arms may press equally, and move simultaneously with equal motion, so as to keep the middle space between them always central in the ring, we provide the outer ends of the several arms with cogs *p p p p*, like sectors of pinions, concentric with the pivots around which the arms turn, the said cogs gearing into sets of corresponding cogs *r r r r* on the inner periphery of the ring gear D, so that neither arm can move without acting by said cog-

gear to move the ring plate E, and thereby moving the other arms equally and simultaneously.

Upon the inner ends of the arms G G G G heads H H H H are pivoted, as seen in Fig. 7. These heads act directly upon the ears of corn and their cobs. On their inner surfaces there are inclined V-shaped projections s s s s, the inclination thereof being such that as the heads turn round with the ring-gear D, which carries them, outside of the ears of corn held from turning with the heads, the said projections, by acting on the cobs by a screw-action, draw down the ears as fast as required to shell the corn from the cobs. Besides, upon the tops of these heads are, respectively, secured cutting and stripping knives I I I I, which, for shelling green corn, are thin and sharp, so as to cut the corn and sever it cleanly from the cobs; but for shelling dry corn they are duller and more rounded, no cutting being required in that operation. These knives or points are shaped substantially as shown in Fig. 6, leaning away from the ears of corn somewhat at the top, and they are rounded at the heel, so as to completely cleave the kernels from the cobs, as well as to cut into the green corn. The knives are secured adjustably in grooves in the heads H H H H by set-screws q q q q. The inner surfaces of the heads H H H H are somewhat concave, to better fit the form of the ears of corn, and, being pivoted to the arms G G G G, they adapt themselves in position to the ears of corn passing between them. The ears of corn are first inserted vertically into the hopper-cylinder K, in which are three or other suitable number of spring strips or fingers, t t t, pressing inward toward each other at their lower ends to direct the ears centrally down between the shelling-heads G G G G. These spring-fingers yield and separate to the size of the ears. The ears are pushed down till the heads can grasp and begin to act upon them. The V-shaped projections on the said heads first act to partially feed down the ears, till the lower ends of the ears are caught by a special feeding and holding device just below the shelling-heads, the peculiarities of which device we now describe. Two swinging arms, L L, are pivoted at their lower ends around the shaft f of the driving-wheel B, and at their upper ends, just below the shelling-heads, they furnish bearings for two feed-rollers, M N. The arms are pressed toward each other at their upper ends by springs u u, secured on the pivot-studs or projections h h of the frame. Thus the required holding pressure is imparted to the feed-rollers. The arms are prevented from moving out of a central position by means of stops v v on the frame, against which shoulders of the arms abut. One roller, M, is caused to revolve with a positive motion by means of a small cog-wheel, w, on the shaft f of the driving-wheel, and gearing into a larger cog-wheel,

x, having its pivot bearing on the arm that bears the said feed-roller, and gearing into a pinion on the shaft of the roller. This roller is fluted longitudinally for acting on the cobs and feeding down the ears. The counter-roller N is a loose roller, and has two or three V-shaped peripheral projections, y y, thereon, which cut into the cobs longitudinally and prevent the ears from turning round, so that the shelling-knives and V-shaped projections on the heads G G G G may act effectually on the ears. Opposite to one of the V-shaped projections on this roller is, or may be, a peripheral groove, z, in the fluted roller M to assist in holding the ears from turning.

What we claim as our invention, and desire to secure by Letters Patent, is—

1. The frame A, formed with a hollow projecting bearing, e, for the driving-wheel, stops v v for the arms L L, pivot-studs for the springs u u, and ring-projection c, having an internal ledge, t, as bearing for the ring-pinion carrying the shelling devices, all substantially as set forth.

2. The loose ring-plate E, bearing the shelling-arms G G G G, pivoted thereto and mounted in a cylindrical projection, b, of the ring-gear D, substantially as and for the purpose herein specified.

3. The arms G G G G, pivoted to the loose ring-plate E, and pressed toward each other by springs m m m m, and provided with sectoral gear p p p p, in combination with the ring-gear D, provided with interior sectoral gear r r r r, substantially as and for the purpose herein specified.

4. The heads H H H H, pivoted to the arms G G G G, and constructed with the inclined V-shaped projections s s s s, substantially as and for the purpose herein specified.

5. In combination with the pivoted arms G G G G, operating as described, and provided with the pivoted heads H H H H, the knives or points I I I I, attached to the said pivoted heads, constructed and arranged to operate substantially as and for the purpose herein specified.

6. The combination of the feed-roller M, mounted on one of the two swinging arms L L, and geared to the driving-wheel shaft through a cog-wheel, x, mounted on said arm, with the roller N, mounted on the other arm L, constructed, arranged, and operating substantially as and for the purpose herein specified.

In testimony that we claim the above we have hereunto subscribed our names in the presence of two witnesses.

CALVIN D. READ.
ELLIS D. READ.

Witnesses:

LEVI WALLACE,
G. W. SANDERSON.