

J. RUSSELL.

Piles for Horseshoe Blank-Bars.

No. 166,227.

Patented Aug. 3, 1875.

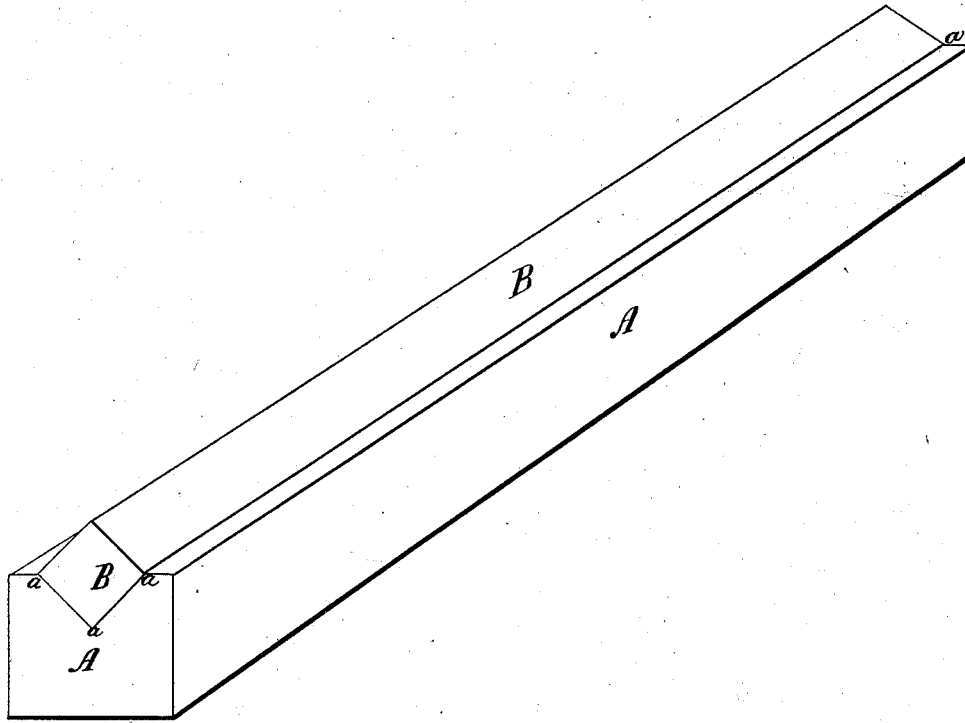

*Witnesses*

*W. M. Edwards.*

*Wm R Whitney*

*Inventor.*

*Jacob Russell*

# UNITED STATES PATENT OFFICE.

JACOB RUSSELL, OF NEW YORK, N. Y.

## IMPROVEMENT IN PILES FOR HORSESHOE-BLANK BARS.

Specification forming part of Letters Patent No. **166,227**, dated August 3, 1875; application filed April 12, 1875.

*To all whom it may concern:*

Be it known that I, JACOB RUSSELL, of the city, county, and State of New York, have invented an Improvement in Piles for the Manufacture of Horseshoes, of which the following is a specification:

The object of this invention is to provide a compound bar of steel and iron suited to the manufacture of horseshoes with steel wearing-surfaces and internal strengthening-rib, and soft, tough iron throughout the other portions of the same, the fabrication of such shoes being greatly cheapened and their quality made better by the use of a bar or blank having the steel and iron combined in due form and proportions.

My invention comprises a novel pile for the purpose mentioned, consisting of an angularly and longitudinally grooved rectangular bar of iron, and a rectangular bar of steel of smaller diameter laid with one angular longitudinal half in the groove of the iron, and the other or remaining half projecting beyond the adjacent flat surface of the latter, by which arrangement and construction of the pile the compound bar made by welding the iron and steel together by drawing through rollers has the steel brought into such relation with the iron that when the horseshoes are made from this resultant compound bar, or from blanks into which such bar may be transversely divided, the steel will constitute an internal or embedded strengthening-rib, the entire length of the shoe measuring from one heel-calk around the front or toe back to the other heel-calk, the steel also projecting at the aforesaid heel and toe to form the hardened or bearing surfaces of calks thereat.

The drawing shows a perspective view of a pile for horseshoes made according to my invention.

A is the rectangular bar of wrought-iron, which should be fibrous and tough, as is that ordinarily employed for the manufacture of horseshoes. This bar may have a diameter of, say, one and one-fourth inch, the four sides being of equal width. The bar A may be of any desired length suitable for being

drawn through ordinary rolling machinery. Formed in one side of this bar, equidistant from the edges thereof, is an angular groove, *a*, the shape and position of which are fully represented in the drawing. B is a rectangular bar of steel, which, when the diameter of the iron bar A is about that hereinbefore stated, may be half an inch in diameter, this bar B of course corresponding with the bar A in length. The bar B is laid in the groove *a* of the bar A, as correctly represented in the drawing, one longitudinal corner of the bar B resting in the acute bottom of the groove, and the two lateral corners being flush or even with the upper or outer edges of the groove—in other words, with the flat adjoining surface of that side of the bar A in which the groove is formed. By this arrangement one-half of the bar B, in a plane drawn from corner to corner, is above or outward from the surface of the bar A, while the remaining half is situated within the same in the groove *a*. The two bars, being thus combined and arranged, may be heated together in a suitable furnace, and then drawn through suitable welding and drawing rolls, which simultaneously weld the steel to the iron, and reduce the whole to the flat bar form desirable in bars required or designed for the manufacture of horseshoes, the steel being embedded within the iron in such form and proportions as to bring the steel into the desired portions of the horse shoe or shoes made therefrom. When the compound bar thus formed is of the length at which it can usually be very conveniently made it is to be cut up into blanks of the proper length, each for a single shoe to be made therefrom, either by machinery or by hand.

What I claim as my invention is—

The pile for the manufacture of horseshoes herein described, composed of the rectangular steel bar B, arranged in the angular groove *a* of the rectangular iron bar A, in the manner and for the purpose herein set forth.

JACOB RUSSELL.

Witnesses:

JAMES A. WHITNEY,  
W. M. EDWARD.