

**J. M. WILSON.**  
**Air-Heating Furnace.**

No. 166,325.

Patented Aug. 3, 1875.

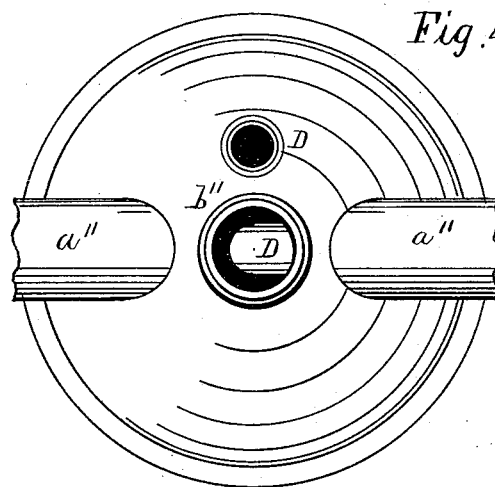
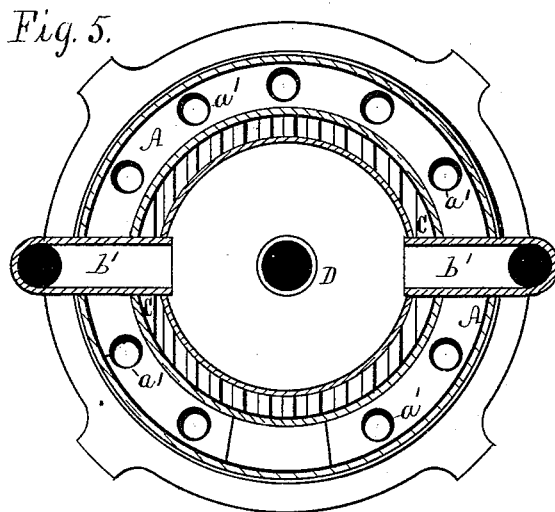
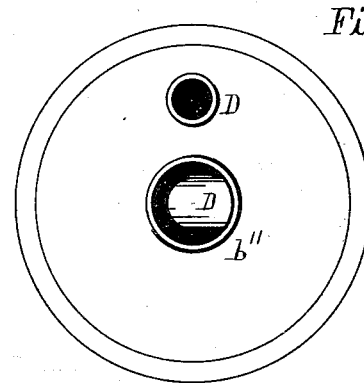
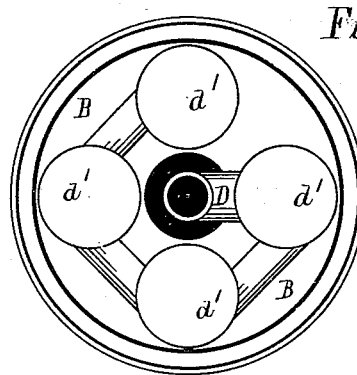
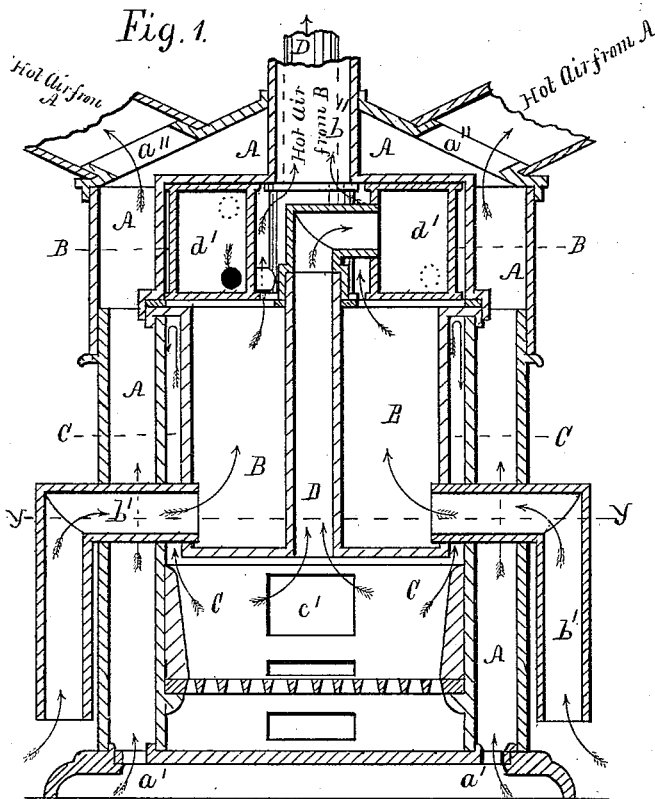

*Witnesses:*  
*Benj. Morison.*  
*Wm. H. Morison.*

*Inventor:*  
*John M. Wilson*

# UNITED STATES PATENT OFFICE.

JOHN M. WILSON, OF PHILADELPHIA, PENNSYLVANIA.

## IMPROVEMENT IN AIR-HEATING FURNACES.

Specification forming part of Letters Patent No. **166,325**, dated August 3, 1875; application filed February 24, 1875.

*To all whom it may concern:*

Be it known that I, JOHN M. WILSON, of the city of Philadelphia, in the State of Pennsylvania, have invented an Improvement in Air-Heating Furnaces, of which the following is a specification:

The object of my invention is to afford a duplex heater, or an air-heating furnace, having two separate incommunicating hot-air chambers heated by one fire, and so inclosed within the ordinary casing or walls of an air-heating furnace that one of the said hot-air chambers will be more strongly heated than the other, and so also that all the air heated or warmed in either of said two hot-air chambers can be conducted into any desired portion of a dwelling without drawing upon the other, and, consequently, diminishing the hot air therein intended for said other portion of the same dwelling.

My invention consists in the peculiar construction and arrangement of two separate incommunicating hot-air chambers, and a single fuel-combustion chamber, within an outside casing or wall, as will hereinafter be described with reference to the accompanying drawing, in which—

Figure 1 is a central vertical section of a portable air-heating furnace embodying my invention. Fig. 2 is a plan view of the open lower end of a detachable case or cover containing a series of heat-radiating drums, forming portions of the smoke and gas flue. Fig. 3 is a plan view of the upper end of the detachable cover shown by Fig. 2. Fig. 4 is a plan view of the detachable top of the furnace. Fig. 5 is a horizontal section of the furnace below the dotted line *y y* of Fig. 1.

The two separate and incommunicating air-heating chambers A and B are heated for the purpose by the one combustion-chamber C. The air-heating chamber B is located concentrically in the combustion-chamber C, and extends from a point at a short distance from the top of the fire-door opening *c'* upward to the top of the cover containing the drums *d' d'*, as shown in Fig. 1. The said drums form portions of the smoke-flue D, which extends concentrically upward from the fuel-holder through the top of the furnace to the chimney (not shown) of the building in which the fur-

nace may be placed. The fresh air to be heated in B enters the lower part of the latter through the externally-projecting pipes *b' b'* to the portion of the building (not shown) to be warmed by the warmed air from B. (See the appropriate arrows in Fig. 1.) The air-heating chamber A surrounds the air-heating chamber B and fire-chamber C with the fuel-holder, and receives the fresh air to be heated through a ring of holes, *a' a'*, in the base-plate of the furnace, (see Figs. 1 and 5,) the air becoming heated by the radiation of heat from the fire-chamber C, which extends upward into the cover, which contains the series of drums *d' d'*, as before referred to. The air in A, thus supplied and heated, passes out through the pipes *a'' a''* to the desired portion of the building to be supplied with the hot-air by this air-heating chamber A.

The top of the furnace is intended to be readily detachable, whether the exterior casing of the body of the furnace be of sheet metal, as shown in the drawing, or of brick-wall, as in the usual stationary furnaces, and the cover containing the drums *d' d'* being in either instance detachable, it will be seen that free access can be had at any time when occasion may require for cleaning out dust of ashes or soot from any part of the interior of the furnace.

It will also be seen that, as the two air-heating chambers A and B are separate and intercommunicating, the air received, warmed, and discharged by each can be used for warming different apartments in a building at the same time, without either drawing upon or reducing the heated air of the other; and, moreover, as the chamber B is entirely within the fire-chamber C, and directly above the fuel-holder, it will be more strongly heated than the surrounding chamber A, and, consequently, as one portion of a building may require a larger amount of warmed air than another portion, my said duplex air-heating furnace affords the requisite means of selecting either of the two volumes of the heated air, as may be desired.

I am aware that an air-chamber surrounding a stove has been divided into four separate parts by partitions, for the purpose of affording independent sources of hot air for

as many rooms in a dwelling, as in 10,333 patent, dated December 20, 1853; and that a foul-air ventilating-pipe has been combined with an air-heating stove, as in Patent No. 128,247 dated June 25, 1872; and therefore I do not desire to claim, broadly, the heating of separate rooms in a building by separate hot-air chambers heated by one fire; nor do I desire to claim any foul-air flue in connection with an air-heating stove or furnace; but

I claim as my invention—

1. The hot-air chamber B, inside of the body of the heater and above the fire, as described, and surrounded by the annular space C, which forms the upper portion of the combustion-chamber, as described, in combination with

the annular hot-air space A, as described, the said chambers A and B receiving their fresh air through *a'* and *b'*, respectively, and discharging the same, heated, through their respective outlets *a''* and *b''*, as set forth, thus forming a double or duplex heater having but one combustion-chamber.

2. In combination with the hot-air chamber B and smoke or gas flue D, the series of drums *d' d'* in the upper part of the fire-chamber C, for the purpose of increasing the radiation of heat into the said chamber B.

JOHN M. WILSON.

Witnesses:

BENJ. MORISON,  
WM. H. MORISON.