

W. HEBDON.
Cloth-Testing Machine.

No. 166,366.

Patented Aug. 3, 1875.

Fig. 1.

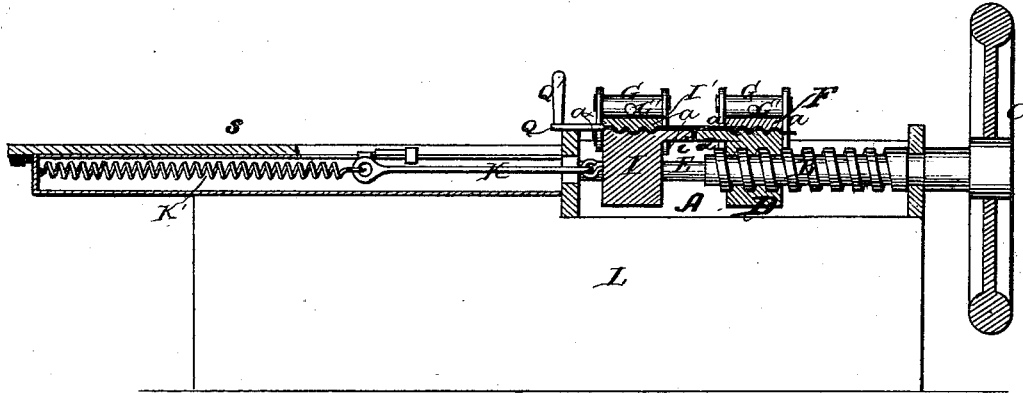
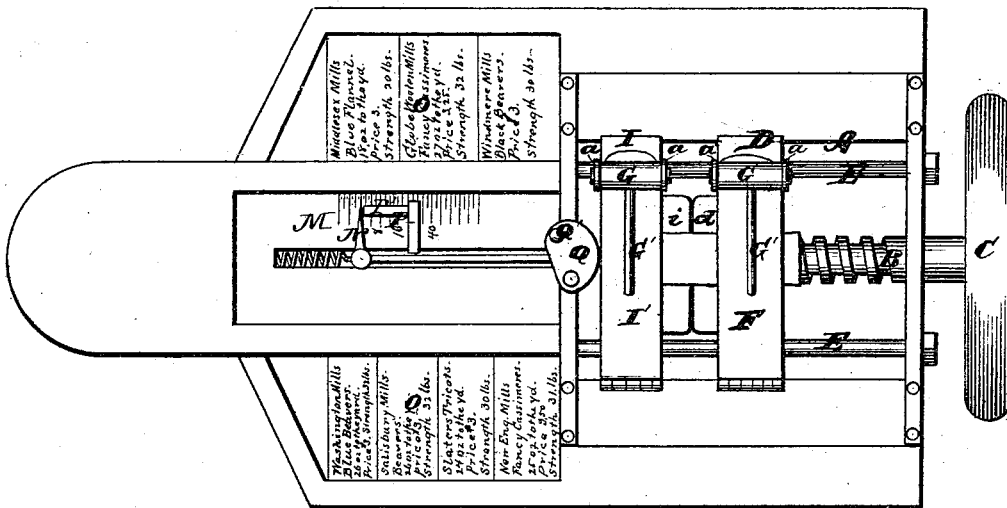

Fig. 2.



Witnesses.
O. F. Tidgin
J. M. Barton

Inventor.
Wm Hebdon.
By his Attys
Caull & Wright & Brown.

UNITED STATES PATENT OFFICE.

WILLIAM HEBDON, OF BOSTON, MASSACHUSETTS.

IMPROVEMENT IN CLOTH-TESTING MACHINES.

Specification forming part of Letters Patent No. **166,366**, dated August 3, 1875; application filed January 20, 1875.

To all whom it may concern:

Be it known that I, WILLIAM HEBDON, of Boston, in the county of Suffolk and State of Massachusetts, have invented certain Improvements in Machines for Testing Cloth, &c., of which the following is a specification:

In the accompanying drawings, forming a part of this specification, Figure 1 is a longitudinal section of my invention, and Fig. 2 a plan view of the same.

The object of the present invention is to effect certain new and useful improvements in machines for testing or ascertaining the tensile strength of cloth, whereby the operation is performed in a convenient, expeditious, and efficacious manner. To this end my invention consists, mainly, in two corrugated chaps or clamps, located one behind the other, to travel on longitudinal guide rods or ways, each chap having a hinged-top clamp or chap corrugated on its bottom, so that when brought down upon the lower chap the cloth is held between the corrugated surfaces of the clamps or chaps, the hinged chaps being held or released by hinged lever-cams bearing upon their swinging ends. My improvements further consist in a spring-balance having an index connected, by a spring-rod, with the rear chap, and operating in such manner as to indicate the tensile strength of goods of various make; also, in a stop-guide arranged to move loosely on the index-plate, and be advanced by the forward movement of the index to the point at which the parting of the cloth particles occurs, at which point it is left until the degree is noted, the index at the breaking of the cloth being carried back by the spring to its original position. My improvements further consist in a cam arranged to turn against the rear of the inner or rear chap, to allow the gradual return, and prevent the sudden springing back, of the latter when released by the parting of the cloth particles. My improvements consist, finally, in forming the box or frame of the machine with glazed openings containing a list of mills or manufacturers, and a description or statement of the weight, price, strength, &c., of standard goods, all of which I will now proceed to describe.

In the drawings, A represents the body or

frame of the machine, consisting of two side plates of metal connected by transverse end plates, or otherwise formed to support two parallel longitudinal guide-rods, E, and a central longitudinal screw-shaft, B, operated by a wheel or crank, C. The shaft B passes through and engages with a sliding carriage or chap, D, arranged to travel on the guide-rods E, and is corrugated on its top in the direction of its length. F is a jaw, chap, or clamp, corrugated on its under surface to correspond with the corrugated surface of the chap D. The chap or clamp F is hinged at one end to the chap D. *a a* are arms hinged or pivoted to the opposite end of the chap D, said arms receiving in their swinging ends the trunnions of an eccentric roller or cam, G, having a handle or lever, G', by means of which the cam is raised up over the swinging end of the hinged chap F, and turned so as to press the latter closely against the upper surface of the chap D. I is a chap similar in construction to the chap D, and having also a hinged clamp or chap, I', held in the same manner as the chap F, above described. The chaps D I are provided with shelves *d i*, which are flush with the upper surfaces of the chaps, and project toward each other, so as to form a continuous bed for the cloth when the chaps are brought together, the cloth being placed upon the bed so formed, and held by the hinged clamps or chaps F I, as shown. The rear of the carriage or chap I is connected with a longitudinal spring-balance, s, having a bar or rod, K, provided at the rear end with a coiled or other spring, K', so arranged as to allow the required tension to the rod K and chap I when drawn out, and to return them to their original positions at the parting of the cloth. The spring-balance is located in the rear portion of a box or frame, L, whose forward portion contains the frame A of the machine. The top of the frame or box L is formed with a central opening, through which is viewed a dial-plate, M, suitably graduated, and marked against a central longitudinal slot, which allows the back-and-forth motion of an index, N, which is connected to the spring-rod of the rear chap. On either side of the central dial-opening are glazed openings, O, in which are inserted

tables or lists of the principal mills or manufacturers, and the weight, price, strength, &c., of their goods, so that the operator may see at a glance whether or not the goods tested agree with the standard quality. Forward of the index is located, to readily travel on the dial-plate, a slide or stop, P, formed with a rearwardly-projecting finger, P', or otherwise formed, as preferred, to receive the abutment of, so as to be advanced by, the index, which carries it forward until the breaking of the cloth retreats the index proper, leaving the slide to mark the point at which the cloth parted, which point being noted the slide is pushed back by hand to its original position. Q is an eccentric plate or cam, pivoted to the frame A in such manner as to be pressed against the rear chap I, as shown in the drawings, and prevent the too sudden recoil of the chap when the tension is released by the parting of the cloth.

The operation is as follows: The two chaps are brought together with their projecting shelves in contact with each other, so as to form a continuous bed between the chaps on which the cloth is placed, the latter also extending across the corrugated surfaces of the chaps. The hinged clamps or chaps F I' are then turned down on the cloth, and their swinging ends are confined by the roller-cams G, as above stated. The shaft B is next rotated, carrying the chap D away from the chap I, and exerting a tensile strain on the cloth, which advances the rear chap I and index N. The spring of the rod K supplies the required tension to draw on the chap I, while it is advanced by the strain on the cloth, the latter being thus pulled by the chaps in opposite directions until the cloth is parted, when the chap I and index N recoil to their original position, leaving the sliding stop P at the point where it was left when the separation occurred, thus designating the degree of strain

under which the cloth particles were parted. The hinged clamps or chaps F I' are then released by turning the cams G off from their swinging ends, thereby allowing the removal of the fragments of cloth and the introduction of other samples.

The hinged upper clamps or chaps and their holding-cams are conveniently and quickly adjusted, and hold the cloth with great firmness.

I claim as my invention—

1. In a cloth-testing machine, two sliding jaws or clamps adapted to hold a piece of cloth or other material between them, one jaw being connected directly to a screw-shaft, which gives it motion, and the other to a spring indicating mechanism, substantially as described.

2. In a cloth-testing machine, the combination of the traveling chaps D I, corrugated on their upper surfaces, the hinged portions F I', corrugated on their lower surfaces, and the cams G, journaled in the swinging arms *a a*, and provided with handles G', all arranged and operating substantially as and for the purpose specified.

3. The chaps D I, having the projections or shelves *d d'*, substantially as and for the purpose specified.

4. The combination of the traveling chaps D I and their attachments with the screw-shaft B and spring-balance *s*, all arranged and operating substantially as described.

5. The cam Q, adapted to prevent the sudden recoil of the chap I, substantially as described.

In testimony whereof I have signed my name to this specification in the presence of two subscribing witnesses.

WILLIAM HEBDON.

Witnesses:

SAMUEL M. BARTON,
C. V. BROWN.