

**B. HERSHEY.**  
**Machine for Welding Chain Links.**

No. 166,370.

Patented Aug. 3, 1875.

*Fig. 1.*

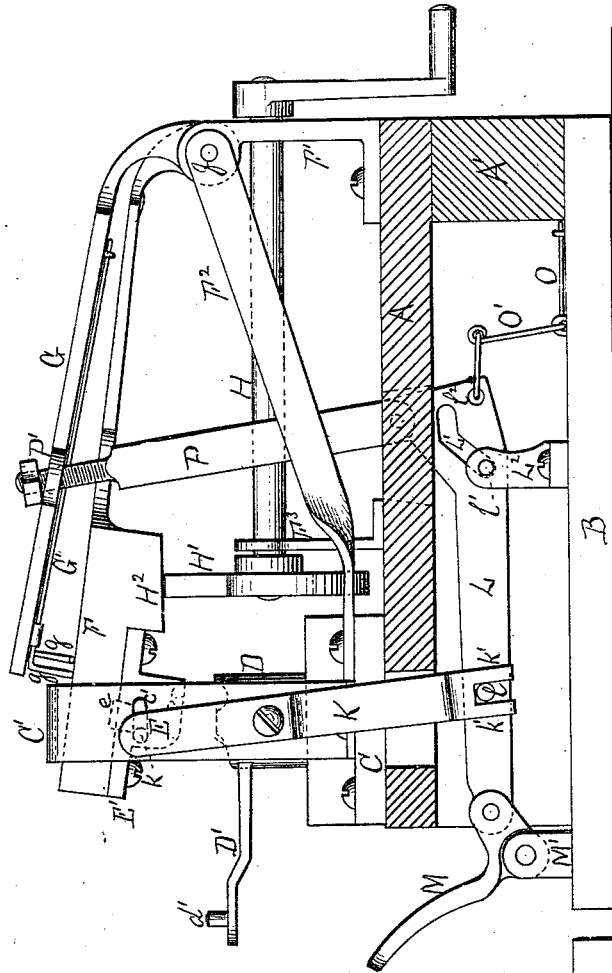

*Fig. 2.*

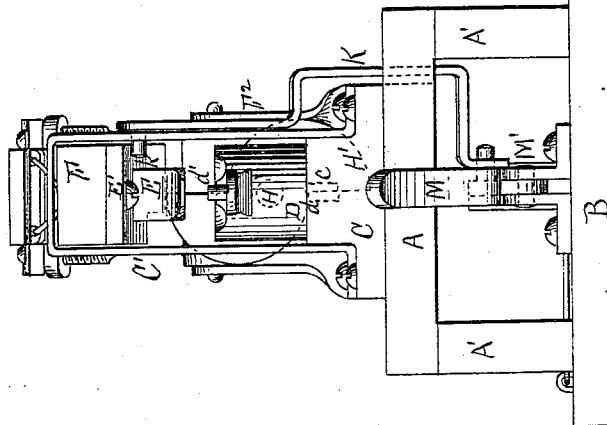

*Witnesses:*

*Edwin James  
 John K. Jones*

*Inventor:*

*Benjamin Hershey.  
 per J. E. J. Holmeads  
 Attorney...*

# UNITED STATES PATENT OFFICE

BENJAMIN HERSHEY, OF ERIE, PENNSYLVANIA, ASSIGNOR TO PITTSBURGH  
CHAIN AND CAR-LINK MANUFACTURING COMPANY.

## IMPROVEMENT IN MACHINES FOR WELDING CHAIN-LINKS.

Specification forming part of Letters Patent No. **166,370**, dated August 3, 1875; application filed  
March 25, 1875.

### CASE I.

*To all whom it may concern :*

Be it known that I, BENJAMIN HERSHEY, of the city and county of Erie, and State of Pennsylvania, have invented certain Improvements in Welding-Machines, of which the following is a full, clear, and exact description, reference being had to the accompanying drawing and the letters of reference marked thereon, making part of this specification, in which—

Figure 1 is a side view, parts being removed. Fig. 2 is a front view.

My present invention relates more particularly to the use of a movable or revolving pivoted die, and the combination of the same with a traveling or hammer swage-die.

The nature of my invention consists in employing, in connection with a rotating die, a movable or traveling hammer swage-die, and which is well adapted for welding or trimming iron of any desired form or contour, and is most admirably suited for dressing down or working up the fins or any excess of stock that may be developed or thrown out through the action of the dies that have effected or produced the earlier stage of the welding.

These fins or the excess of metal can readily and effectually be reduced, so as to leave an exceedingly neat finish through the repeated blows of the narrow-faced swage-die.

The construction and operation of my invention are as follows:

A is the bed-piece of the machine, and, by suitable supports A' A', is secured to the platform B. At the front section of the bed-piece A is secured a die-plate, C, and which, at its center, is provided with a central vertical slotted or socket bearing, *d*, of such diameter as to permit of the bearing-pin *c* snugly and loosely fitting and working therein, so as to allow of the free rotation of the die. D is the lower die, and is formed with a cavity of any desired form, and is provided with a vertical axial bearing arm or shaft, *e*. This die D is formed with or has attached thereto an arm, D', and which is provided at its outer section with a bearing pin or stirrup, *d'*. This arm has a double function: It first serves as a conven-

ient handle for rotating the die D, and also as a bearing for the link or other article to be welded, serving to retain and steady the same for the direct action of the traveling or movable die E.

As illustrated in the accompanying drawing, the die E is a narrow-faced swage-die, and, by a suitable bearing-plate, E', is secured, so as to be detachable at pleasure, to the enlarged section of a hammer-arm, F. This arm F is secured to a suitable axial arm or shaft, *f*, and which is journaled in suitable bearings F<sup>1</sup>, bolted to the platform at its rear section. This bearing-plate is further strengthened by means of diagonal brace-rods F<sup>2</sup> F<sup>2</sup>, and which are bolted at their forward section to the die plate or bed C. G is the bed-plate of the spring G', and which is secured to the axial arm *f*, and extends in a longitudinal direction immediately over and above the hammer-arm F.

The spring G' is arranged on said plate in such manner as to leave its lateral lever-arms *g g* in such position that, through the movements of the hammer-arm the full torsional power of the spring shall be exerted in adding force and power to the downward movement of the hammer swage-die. H is a horizontal cam-shaft, and is journaled in the bearing F<sup>1</sup>, and a bearing, F<sup>3</sup>, bolted to the platform, and immediately at the rear of the die-plate C. To this shaft H is secured a cam-wheel, H<sup>1</sup>, and which operates the hammer-arm F through a bearing, H<sup>2</sup>, provided on its lower face. K is a stop-arm, and is secured by a pivot-bearing to a stirrup-shaped bearing-plate, C', and which allows of its free oscillation or swinging movement. This stop-arm K is provided with a bearing-pin, *k*, on its inner face, and which passes through and travels in an oblong slot, *c'*, in the bearing C'. This pin, when the lower section of the arm K is moved forward, enters a vertical slot, *e*, cut through the bearing-plate E' of the die E, and also through the enlarged section of the hammer-arm F; and when the pin *k* is in this position it no longer arrests the movement of the hammer-arm F, as it does when it engages with the uncut sec-

tion of the bearing E', but allows of the free movement of the hammer-arm, and of its being alternately elevated and released by the cam-wheel H<sup>1</sup>. This stop-arm K is slotted at its lower section, and which slot provides bearing-prongs k' k', which are acted on by a bearing-pin, l, on a horizontal lever, L, as the stop-arm is pushed forward and backward to alternately engage and release the hammer-arm F. This horizontal lever L, by means of a slotted bearing, L<sup>1</sup>, is secured so as to work over a bearing-pin, l<sup>1</sup>, secured in a suitable support, L<sup>2</sup>, bolted to the platform B. At its forward section this lever L is pivoted to a treadle, M, which works in suitable bearings M', also secured to the platform B. At its rear section, by means of an eye, l<sup>2</sup>, the lever L is secured to the lateral lever-arm O' of a torsion-spring, O. This spring O is so arranged and secured on the platform B that its tension is constantly employed in so drawing on the lever L as to cause it, through its connection with the stop-arm K, to so move the latter as to leave its bearing-pin k in a position to catch under the bearing E' and arrest the movement of the hammer-arm F and die E. P P are two bearing-arms, and are attached to the lever L, and to the spring bed-plate G, by suitable flanged bearings, P' P'. The arrangement of the stop-arm K, lever L, treadle M, spring O, and bearing-arms P P in connection with the hammer F and spring bed-plate G, it will be observed, is identical in form, arrangement, and operation with similar devices described and claimed in connection with a former application, and is shown in the accompanying drawing simply to illustrate a practical mechanism to be used in connection with the dies which constitute the distinctive subject-matter of my present invention; but I do not desire to be understood as limiting myself to this mechanism, as the dies can be placed and operated in any suitable machine.

I will now briefly describe the operation of the dies in connection with the welding of a chain-link. The first stage of the welding having been effected through either of the sets of dies described in my former applications, and it now being desirable to further work the excess of stock at the welded section of the link, and to reduce or tuck in the fins that may have been developed, the welded section of

the link is placed in the cavity of the die D, and its opposite section secured over the bearing pin or stirrup d' of the arm D', and which secures and retains the link in proper position to secure the most positive and direct action of the die E. The link being thus held, and power having been previously applied to the shaft H and cam-wheel H<sup>1</sup>, and the treadle being now depressed, the stop-arm K, through the lever L, is so moved as to throw its bearing-pin k in the slot e, when the hammer instantly falls, so as to permit its bearing H<sup>2</sup> to be acted on by the cam-wheel H<sup>1</sup>, and which, of course, imparts the desired hammering movement to the die E, the arm D' providing a most convenient means of so rotating the die D as to cause it to bring the different sections of the weld in position to be properly acted on and dressed through the hammering pressure of the narrow face of the swage-die E. So soon as the operation is finished and the welded section of the link reduced to the desired form and dimensions, the pressure is relieved from the treadle M, and the stop-arm K is instantly automatically moved through the spring O and lever L, so as to leave its pin k in position to catch under the bearing E', and thus arrest the movement of the hammer-arm F precisely as described in my former application. The die E being now temporarily held in a stationary position, the link can readily be removed and a fresh one inserted and secured on the die D and its bearing-arm D'.

What I claim as new, and desire to secure by Letters Patent of the United States, is—

1. In a chain-link-welding machine, the rotating die D and the movable swage-die E, the same being combined as described, to operate substantially as and for the purpose specified.

2. In combination with the movable swage-die E, a rotating die, D, having an arm, D', with a bearing-pin, d', attached, as and for the purpose specified.

In testimony whereof I have signed my name to this specification in the presence of two subscribing witnesses.

B. HERSHEY.

Witnesses:

EDWIN JAMES,  
JOS. T. K. PLANT.