

**B. HERSHEY.**  
**Machine for Welding Chain Links.**

No. 166,371.

Patented Aug. 3, 1875.

*Fig. 1.*

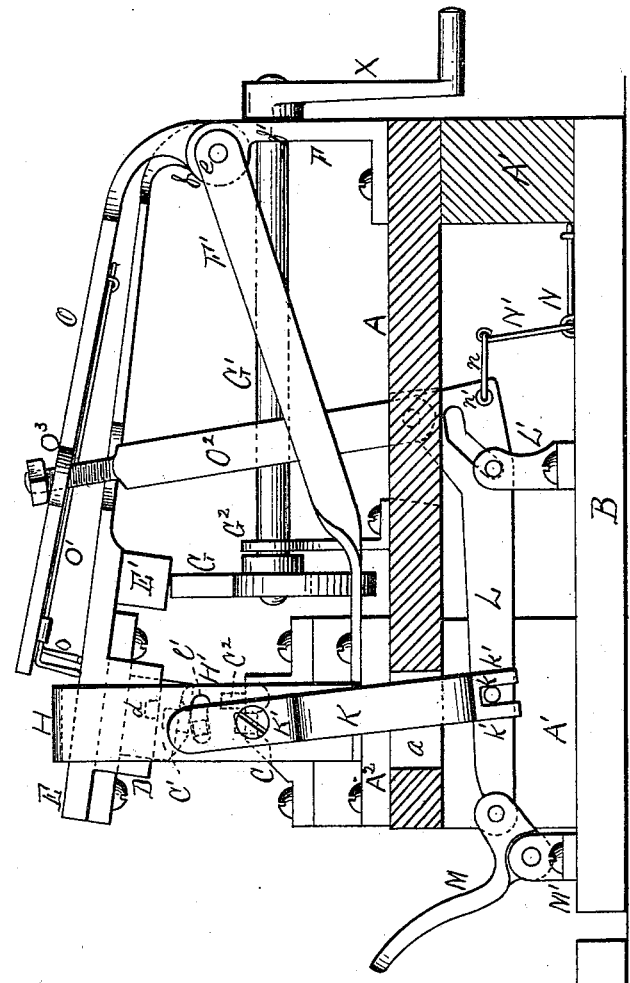

*Fig. 2.*

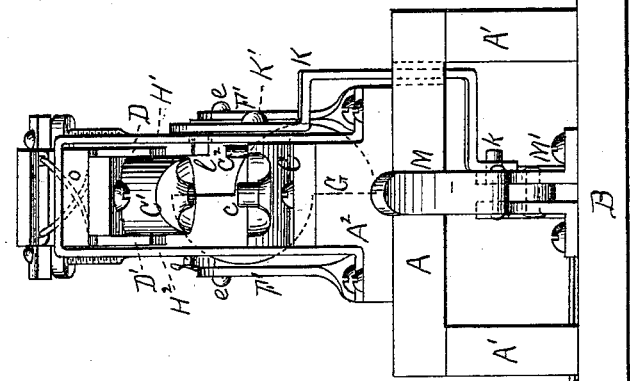

*Witnesses:*  
 Edwin James.  
 John K. Jones

*Inventor:*  
 Benjamin Hershey.  
 per J. E. J. Holmeads  
 Attorney.

# UNITED STATES PATENT OFFICE.

BENJAMIN HERSHEY, OF ERIE, PENNSYLVANIA, ASSIGNOR TO PITTSBURGH  
CHAIN AND CAR-LINK MANUFACTURING COMPANY.

## IMPROVEMENT IN MACHINES FOR WELDING CHAIN-LINKS.

Specification forming part of Letters Patent No. **166,371**, dated August 3, 1875; application filed  
March 18, 1875.

### CASE F.

*To all whom it may concern:*

Be it known that I, BENJAMIN HERSHEY, of the city and county of Erie, and State of Pennsylvania, have invented certain Improvements in Welding-Machines, of which the following is a full, clear, and exact description, reference being had to the accompanying drawing and the letters of reference marked thereon, making part of this specification, in which—

Figure 1 is a side view, parts being removed. Fig. 2 is a front view.

My present invention is an improvement on the welding-machine embraced and claimed in an application for Letters Patent of the United States filed by me March 13, 1875.

The nature of my invention consists in securing the traveling or movable die in a flanged bearing attached to the hammer-arm, and in arranging, in connection with said arm and its bearing, a pivoted stop-arm, connected with, and operated through the application of, a treadle, lever, and spring, precisely as the stop-arm in the application referred to is described as acting; but in my present invention the bearing-pin of the stop-arm, and which arrests the movement of the hammer-arm that carries the traveling die, is never freed from its connection with the bearing of said die. A spring automatically draws the arm to such a position as to leave its bearing in position to catch and arrest the flanged bearing of the die, and which instantly renders the hammer-arm inoperative, precisely as the stop-arm in the application referred to is thrown forward to catch and arrest the downward movement of the gate that carries the traveling die; but when the arm is drawn back through the depression of the treadle, instead of its bearing being freed from contact with the bearing of the traveling die, it is caused to enter an oblong slot in said bearing, and which permits the free and uninterrupted movement of the hammer-arm through the action of its motor-cam so long as the pressure on the treadle is continued.

The construction and operation of my invention are as follows:

A is the bed-plate of the machine, and A<sup>1</sup> A<sup>1</sup> are its supports, and which are seated and firmly secured on a platform or other suitable bearing, B. On the bed-plate A is seated and bolted the bearing A<sup>2</sup>, and to which is secured the base-plate of the stationary die C. The cavity of this die and that of the traveling die C<sup>1</sup> may be of any desired form, my present invention having no reference whatever to any peculiar contour of the die-cavities. The movable die C<sup>1</sup> is secured in vertical flanged bearings D D', and which are cast with, or otherwise firmly secured to, the hammer-arm E, and which arm E extends in a longitudinal direction, and is secured to an axle-arm or shaft, e, and which is secured so as to work or revolve freely in journals f f, provided at the upper section of a vertical bearing-plate, F, and which is securely bolted to the rear section of the bed-plate A. This plate is further strengthened by brace-rods F' F', and which are secured at their forward end to the bearing A<sup>2</sup>, that supports the base-plate of the stationary die C. This hammer-arm E is so secured in its bearings as to allow of its free vertical swinging and falling movement. This hammer-arm E is provided with a bearing shoulder or projection, E', and which is arranged at such position with the arm as to engage with the cam-wheel G, and which is keyed to a longitudinal shaft, and which is journaled so as to work freely in a suitable bearing, f', of the plate F, and a bearing, G<sup>2</sup>, bolted to the bed-plate A, and immediately in the rear of the stationary die. In the flanged bearing D, that works next the bearing-plate H<sup>1</sup>, to which the stop-arm K is pivoted, is a vertical slot, d, and which works over the bearing-pin of the stop-arm, when the latter is moved forward, so as to leave the hammer-arm E free to act.

H is an oblong vertical stirrup-shaped bearing, and which fits over the outward section of the hammer-arm E and its flanged bearings D D', and between which latter are secured the traveling die C<sup>1</sup>. The vertical surfaces or plates H<sup>1</sup> H<sup>2</sup> of this bearing H serve to guide and direct the movements of the traveling die

C<sup>1</sup>. This bearing H is firmly bolted to the support A<sup>2</sup>, and on which is secured the bed-plate of the stationary die C. To the vertical bearing-plate H<sup>1</sup> of the stirrup H is secured at a pivot-center, K', and so as to allow of its free vibrating or oscillating movement, the stop-arm K. This arm K is provided with a bearing-pin, *l*, and which projects at right angles from its inner surface. This bearing-pin projects through and works in a longitudinal slot, *l'*, in the support H<sup>1</sup>, to which the arm K is pivoted. This arm passes through a mortise, *a*, in the bed-plate Δ, and terminates in forked arms or prongs *k'*, and which fit over a bearing-pin, *k*, attached to a lever-arm, L, and which extends in a longitudinal direction, and is secured by a slotted bearing over a pin supported in suitable bearings L', secured at or near the center of the platform B. The forward section of this lever L is pivoted to a treadle, M, and is journaled in suitable bearings M', secured at the forward section of the platform B. N is a torsion-spring, so secured on the platform B as to leave its lateral lever-arm N' extending toward the enlarged or rear section of the lever-arm L. The lateral lever-arm N' of the spring is connected by a link, *n*, to the eye *n'* of the lever L. O is the bed-plate of the spring, and terminates in a slotted curved section, and is secured to the axle-shaft *e* of the hammer E. On this bed is secured, so as to leave its lateral lever-arms *o o* in position to act on the upper surface of the hammer E, the torsion or power spring O<sup>1</sup>. From this bed-plate O, and secured in suitable flange-bearings O<sup>3</sup> O<sup>2</sup>, project the bearing or draft arms O<sup>2</sup> O<sup>2</sup>, and which are secured at their lower section to the treadle-arm L. O<sup>2</sup> is a stop-pin or stirrup, secured at the rear section of the stationary die C, and against which the flanged bearing D of the hammer-arm E strikes when the die C<sup>1</sup> has fallen to such position as to permit of its cavity properly registering in such manner with the cavity of the die C as to effect, through their joint action, the desired weld. This pin or stirrup so acts as to break the destructive jar of the pounding of one die-face against the other, while it in no manner retards or interferes with the effective action of the dies.

From the foregoing full and detailed description, the operation of my present improvement will readily be understood.

The machine being in the position shown in the drawing, power is applied to the arm G' by means of a crank, X, engine, or any other motor. The revolution of this arm G<sup>1</sup> carries with it the cam-wheel G; but the pin *l* of the stop-arm being under the flanged bearing D of the hammer-arm E, its bearing E' is held

free from contact with the cam, and so the revolutions of the latter fail to impart any movement to the hammer-arm and the movable die C<sup>1</sup>. Free access is now afforded for the insertion of the link to be welded, and for the proper placement and adjustment of the link in the cavity of the die C and around its bearing-tongue *c*. So soon as the link is properly arranged in the die, the treadle M is depressed to a degree sufficient to overcome the tension of the spring N and to draw the lever L forward. This movement of the lever causes its bearing-pin *l*, pressing against the forward prong *k'* of the stop-arm K, to move said arm to a position that causes its bearing-pin *l* to enter the slot *d* of the flanged bearing D, and which causes the hammer E to drop, leaving its bearing E' in position to be acted on by the cam-wheel G, and which alternately lifts and releases the hammer-arm, and thus imparting the necessary movement to the traveling die C<sup>1</sup> to effect the weld; and the force of the blow of the die is greatly augmented through the tension of the spring O<sup>1</sup>, which the drawing forward of the lever through its arms O<sup>2</sup> O<sup>2</sup> has brought into requisition. So soon as the welding operation is completed, the pressure from the treadle is removed, and the spring N instantly, automatically, draws back the lever L, and which so moves the stop-arm K as to free the pin *l* from connection with the slot *d*, and to leave it in position to catch under the flanged bearing-plate D at the next upward movement of the hammer, and which will again arrest the movement of the traveling die, and when the welded link can be removed and another inserted.

What I claim as new, and desire to secure by Letters Patent of the United States, is—

1. The hinged hammer-arm E, having a flanged head, D, in which there is a vertical slot, *d*, stirrup H, having horizontal slot *e'*, stop-arm K, having bearing-pin *l*, the lever L, spring N, and treadle M, the whole being constructed, combined, and arranged to operate substantially as described.

2. The hinged hammer-arm E, cam G, horizontal shaft G<sup>1</sup>, the bed-plate O, having a spring, O<sup>1</sup>, attached, arms O<sup>2</sup> O<sup>2</sup>, lever L, spring N, and treadle M, the whole being combined and arranged to operate substantially as described.

In testimony whereof I have signed my name to this specification in the presence of two subscribing witnesses.

B. HERSHEY.

Witnesses:

EDWIN JAMES,  
JOS. T. K. PLANT.