

B. F. STURTEVANT.

Machine for Pointing Ribbon Peg Wood.

No. 166,429.

Patented Aug. 3, 1875.

Fig. 1.

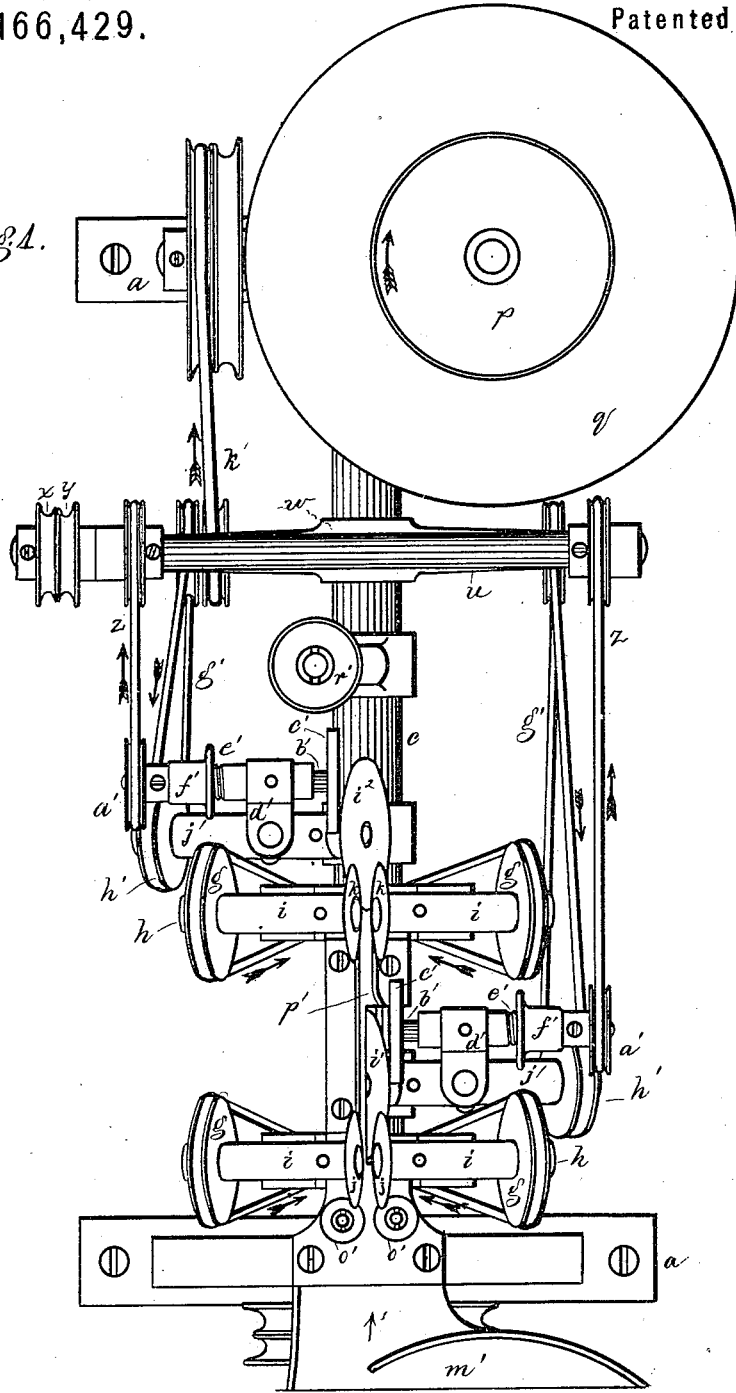

WITNESSES.

Mr. W. Frothingham.

Wm Pratt.

INVENTOR:

Benjamin F. Sturtevant

PER *Coosby Gregory* ATTYS

B. F. STURTEVANT.

Machine for Pointing Ribbon Peg Wood.

No. 166,429.

Patented Aug. 3, 1875.

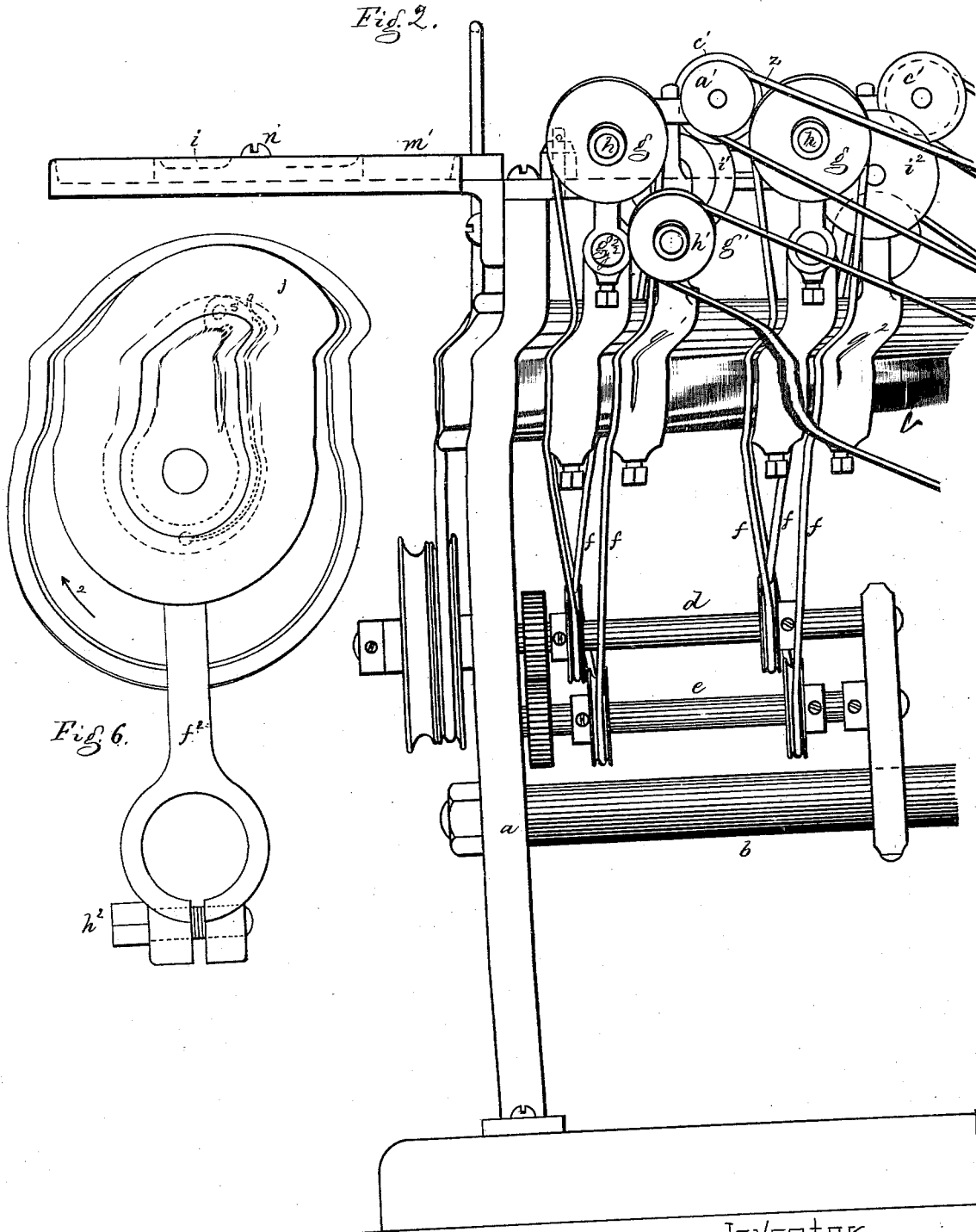

WITNESSES.
 M. W. Frothingham.
 Wm. Pratt.

INVENTOR.
 Benjamin F. Sturtevant
 PER Crosby & Mayory Att'ys.

B. F. STURTEVANT.

Machine for Pointing Ribbon Peg Wood.

No. 166,429.

Patented Aug. 3, 1875.

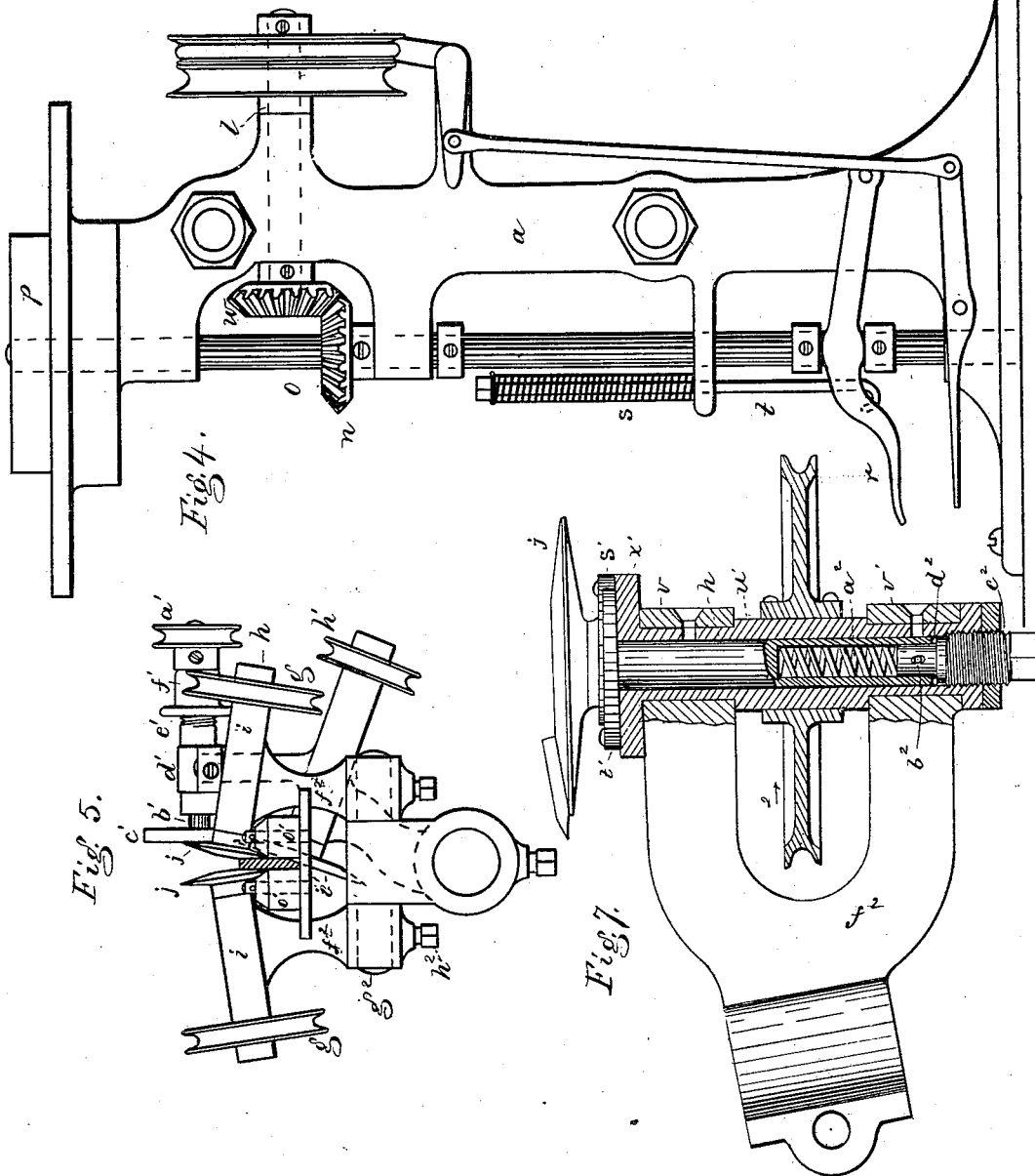

Witnesses.

Mr. W. Frothingham
Wm. Pratt

Inventor.

Benjamin F. Sturtevant

PER Lewis & Gregory
Attys.

UNITED STATES PATENT OFFICE

BENJAMIN F. STURTEVANT, OF BOSTON, MASSACHUSETTS.

IMPROVEMENT IN MACHINES FOR POINTING RIBBON PEG-WOOD.

Specification forming part of Letters Patent No. **166,429**, dated August 3, 1875; application filed March 27, 1875.

To all whom it may concern:

Be it known that I, BENJAMIN F. STURTEVANT, of Boston, in the county of Suffolk and State of Massachusetts, have invented an Improvement in Machines for Pointing Ribbon Peg-Wood, of which the following is a specification:

Ribbon peg-wood is now cut from around the log in long strips and with square edges.

This invention relates to mechanism for beveling or cutting away the two corners of one edge of such a strip of ribbon peg-wood, to form a point-forming edge for such a strip, and to serve for points of pegs to be subsequently cut from such a strip in a pegging-machine.

This invention consists in the combination, with reels for holding and receiving such a ribbon of peg-wood, of rotating disk-cutters for removing the edges of the strip to form a sharp edge, or nearly so; also, in the combination, with the cutters, of rotating holding-guides, working against the peg-ribbon, as hereinafter described.

Figure 1 is a top view of a machine embodying my improved cutting mechanism, with the reel for holding the peg-ribbon to be pointed partially broken away. Fig. 2 is a partial side view of the machine, and of that end of it broken away in Fig. 1. Fig. 3 is also a partial side view, and Figs. 2 and 3 together show a complete side view. Fig. 4 is an end view, showing the means for winding the ribbon into a coil. Fig. 5 is a detail view of the rotating holding-disks and a cutter and grinder, with a piece of peg-ribbon in position, and as would appear if looking in the direction of the arrow 1 in Fig. 1; and Figs. 6 and 7 are details of the rotating holding-disks.

In the drawing, *a* represents the end frames of the machine, connected by cross-bars *b c*, these parts serving to support the working parts of the machine. The driving-shaft *d*, provided with a fast and loose pulley, is supported in the end frame, and by a standard secured on the cross-bar *b*, and the driving-shaft has a pinion gearing in a second pinion on a shaft, *e*, parallel with the driving-shaft, and each of these shafts have two pulleys, connected, by means of endless bands *f*, with

pulleys *g* on shafts *h*, resting on bearings *i*, and carrying rotating guiding-disks *j k*, which, through the doubled bands *f*, passing as shown, rotate the guiding-disks *j k*, so that they will move at about the speed with which the ribbon is first moved through the machine by the action of the winding mechanism, the rotation of the disks, which also serve the purpose of guides, preventing friction, and when first starting a ribbon through the machine these rotating holders or guides *j k* act as feeders and lead the strip properly. In Fig. 5 the holders *j j* are shown as acting on the sides of a ribbon just entering a guide-box. At *l*, Fig. 4, is a second shaft, provided with a fast and loose pulley, and with a bevel-gear, *m*, engaging a bevel-gear, *n*, on the shaft *o* of the reel or spool *p*, adapted to rotate and to rise and fall within a table, *q*, the shaft *o* being movable in its bearings, forming part of frame *a*, by means of a lever or treadle, *r*, pivoted to the frame, and the shaft *o* and treadle are held up by the action of a spiral spring, *s*, on a rod, *t*, the spring being supported on a bracket from the frame, and the rod resting on the top of the spring, and being connected with the treadle. The bevel-pinion *n* is attached to the shaft *o*, so as to rotate it, and also so that the shaft may move endwise through the bevel-pinion. Two shafts, *u v*, are supported in bearings on a cross arm or frame, *w*, attached to cross-bar *c*. The shaft *u* has fast and loose pulleys *x y* to give it motion, or to allow it to remain at rest, and bands *z z*, leading from other pulleys on shaft *u*, and engaging pulleys *a'* on shafts *b'*, rotate the grinding-wheels *c'*, made of emery or other suitable known material. These shafts *b'* rest in bearings or sleeves *d'*, screw-threaded at *e'*, to receive nuts *f'*, attached to the shafts, so as to turn thereon, and also so as to carry the shafts forward or backward through the sleeves or bearings *d'* as the nuts are moved horizontally, so as to keep the grinding or cutter-sharpening wheels properly in contact with the edge of the cutting-disks, in order to keep them sharp. Shaft *v*, directly under shaft *u*, as shown in this instance, has also fast and loose pulleys, and other pulleys fast to this shaft are, by bands *g'*, connected with pulleys *h'* on the ends of shafts

B. F. STURTEVANT.

Machine for Severing Sole-Fastening Webs.

No. 166,430.

Patented Aug. 3, 1875.

Fig. 1.

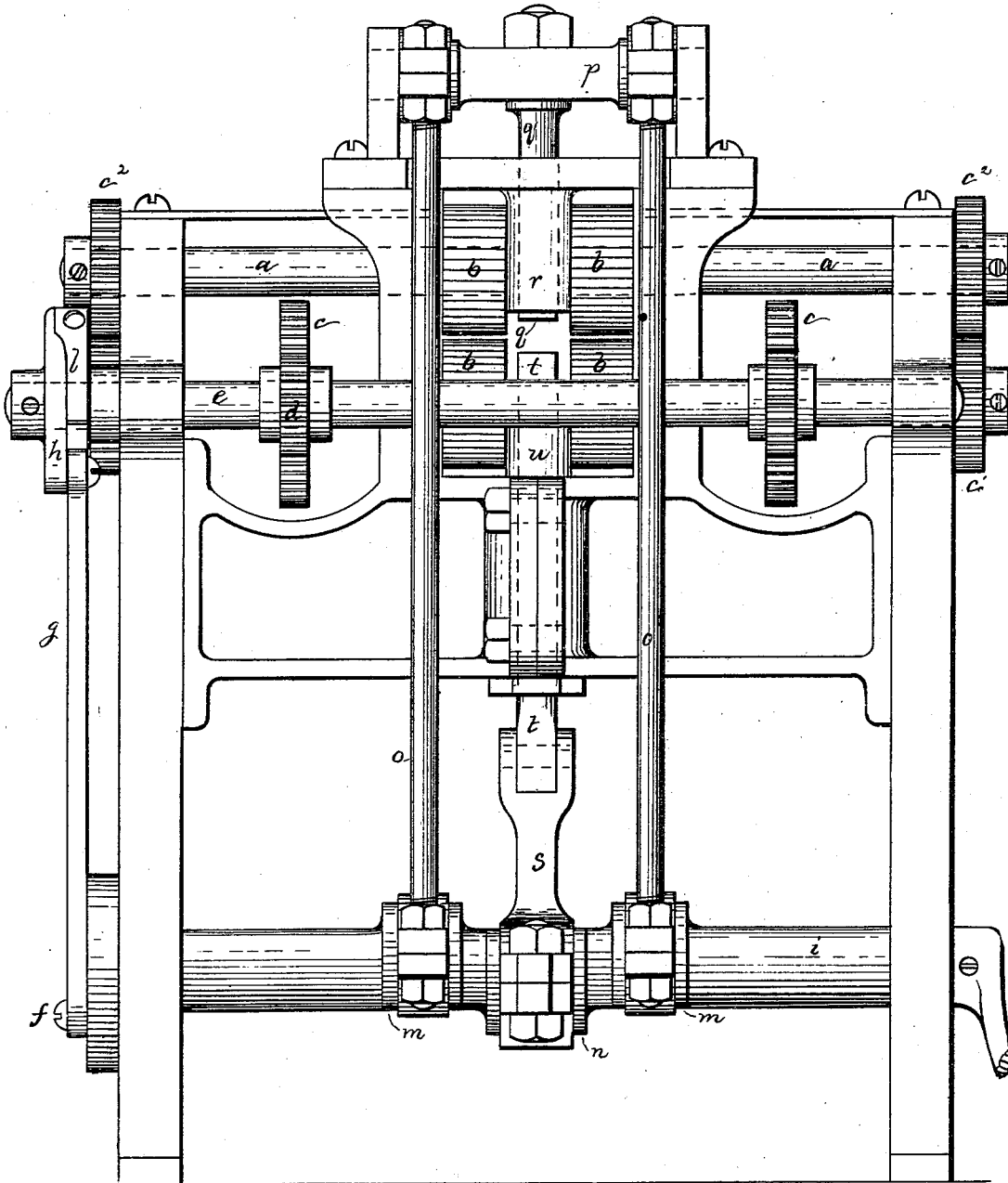

Witnesses.

L. H. Batimer,
W. P. Pratt.

Inventor.

Benjamin F. Sturtevant
PER Crosby & Mangory Att'ys.

