

A. O. KITTREDGE, W. H. & W. J. CLARK.
Mallets for Smoothing Sheet Metal.

No. 166,703.

Patented Aug. 17, 1875.

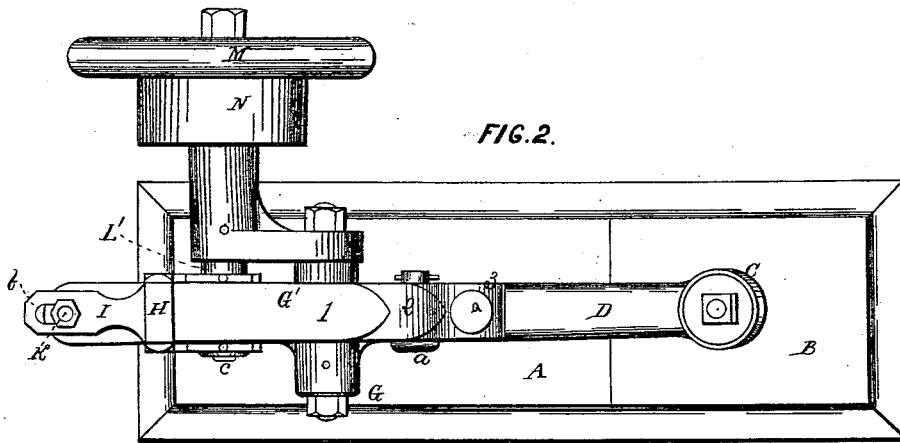
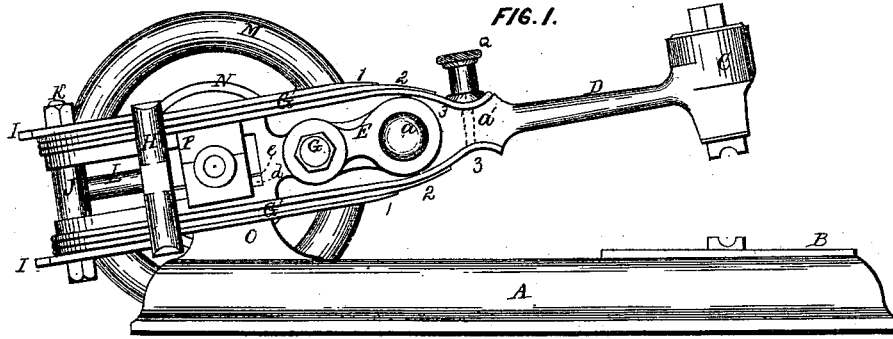

FIG. 5.

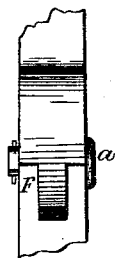

FIG. 3.

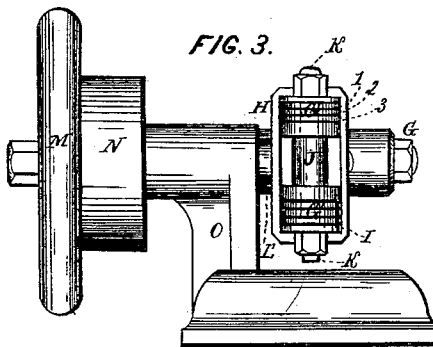

FIG. 4.



WITNESSES.

A. F. Coornell.
J. Cladder

INVENTORS.

A. O. Kittredge, W. H. Clark.
W. J. Clark.
Per. Curridge Dec.
Atty.

UNITED STATES PATENT OFFICE

ANSON O. KITTREDGE, WILLIAM H. CLARK, AND WILLIAM J. CLARK, OF SALEM, OHIO, ASSIGNORS TO KITTREDGE CORNICE AND ORNAMENT COMPANY, OF SAME PLACE.

IMPROVEMENT IN MALLETS FOR SMOOTHING SHEET METAL.

Specification forming part of Letters Patent No. 166,703, dated August 17, 1875; application filed June 7, 1875.

To all whom it may concern:

Be it known that we, ANSON O. KITTREDGE, WM. H. CLARK, and WM. J. CLARK, of Salem, in the county of Columbiana and State of Ohio, have invented a certain new and Improved Mallet, of which the following is a full, clear, and complete description, reference being had to the accompanying drawings making part of this specification, in which—

Figure 1 is a side view of the mallet. Fig. 2 is a plan view. Fig. 3 is an end view. Figs. 4 and 5 are detached sections.

Like letters of reference refer to like parts in the several views.

The invention above referred to is a mallet for smoothing and straightening sheet metal; and the special object of the invention is to give to the handle of the mallet a flexibility by means of a joint, so that the blows given by the mallet may have the characteristic of a blow given by a mallet held in the hand, the invention being an improvement of a mallet for which a patent was granted to us the 4th day of August, 1874. Of the above-said invention the following is a full and complete description:

A in the drawings represents a bed or table, whereon is arranged the mallet, the fore part B of which is raised above the face of the table, forming a striking-surface for the mallet. C is the mallet, which is constructed substantially in the same manner as that described in our patent of August 4, 1874, above referred to, differing only in the shape of the block. D is the handle of the mallet. Said handle is connected to the vibrating beam E by a joint, as seen at F, Fig. 5, whereby is obtained to the mallet a vertical movement independent of that for giving the blows. *a* is the pivotal bolt, whereby the connection of the handle to the beam is secured. G is a pintle, supporting the vibratory beam, and is the axis of its vibration. The handle is sustained in a straight relation to the vibratory beam by a spring, G', consisting of the overlapping leaves 1 2 3, Fig. 1, on the upper side, and by corresponding springs on the lower side. Said springs are secured to the bifurcated end of the vibratory beam by a

yoke, H, Fig. 3, under the upper and lower sides of which is driven a key, I, whereby the ends of the leaves of the springs are drawn down tightly upon the end of the beam, and upon each other. The ends of the beams are prevented from being drawn together by the pressure of the keys exerted upon them by a sleeve, J, inserted between the ends, as shown in Fig. 1. Through the sleeve passes the bolt K, and which also passes through the slots *b* in the end of the keys, as shown in Fig. 2, thereby holding the keys from slipping from under the yoke, and the sleeve from working from between the ends of the beam, and at the same time holding the yoke in place, or from moving by means of the bar L, Fig. 1, connecting the yoke and sleeve to each other. The end *c* of the shaft L', carrying the fly-wheel M and pulley N, and which shaft has its bearing in the standard O, is eccentric to the axial line of said shaft, as will be seen in Fig. 4, which represents a detached view of the shaft. In the bifurcated end of the vibratory beam is fitted a sliding journal-box, P, in which the eccentric end *c* of the shaft L' is received, and whereby the beam is vibrated for operating the mallet. Said box is continued in close-fitting relation to the beam by a rubber spring, *d*, inserted between the lower side of the journal-box and the arm of the beam. Said rubber is covered by a metal plate, *e*, whereon the box slides in operating the beam and mallet.

In our former power-mallet, the handle of the mallet is fixed rigidly to the vibratory beam. The handle is also made thin in order to secure to it flexibility for lightness and ease of stroke, and to adapt it to different sizes of metal. The thinness of the handle was compensated by springs, one on each side above and below. Said springs added strength to the handle, and at the same time contributed to the lightness, ease, and springiness of stroke so desirable in this class of mallets for the smoothing of sheet metal, where a firm, solid, unyielding blow is not needed.

In our former machine the tightness of the handle rendered it liable to break, and the side springs, however carefully made, were

liable to the same accident—to avoid which, in this our new machine, we connect the handle of the hammer to the vibratory beam by a joint, as above described, and support the same in line therewith by the springs referred to.

By this means we are enabled to make the handle of the mallet stronger, so that it cannot break, and at the same time secure the same end, in respect to the stroke of the mallet, in a more perfect manner. The joint permits the recoil of the mallet, and to adjust itself to a variable thickness of metal, while the tendency to the springs is to keep the handle in line with the beam and strengthen its connection therewith.

The practical operation of the mallet is substantially as that described in the specification of our patent referred to, and therefore need not here be described.

In the event of the springs becoming loose, they can be tightened by driving in the keys, which, when so driven in, are again made fast by the bolt.

Q is an oil-cup for oiling the ends of the springs in their connection with the handle;

and a hole (indicated by the dotted lines *a'*) is made through the handle, so that the oil can pass through from the oil-cup to the lower spring, thereby oiling the upper and lower springs at the same time.

We claim—

1. The handle D, jointed to the vibratory beam E, in combination with the springs G', substantially in the manner as described, and for the purpose set forth.

2. The yoke H, bar L, sleeve J, keys I I, and bolt K, in combination with the springs G and vibrating beam E, in the manner substantially as described, and for the purpose specified.

3. The oil-cup Q and oil-hole *a'* in the handle D, in combination with the springs G' and said handle D, whereby both upper and lower springs are oiled at once, as herein set forth.

ANSON O. KITTREDGE.

WILLIAM H. CLARK.

WILLIAM J. CLARK.

Witnesses:

R. W. TAYLER, Jr.,

JAMES R. CAREY.