

E. D. LEAVITT, Jr.
Steam-Engines.

No. 166,706.

Patented Aug. 17, 1875.

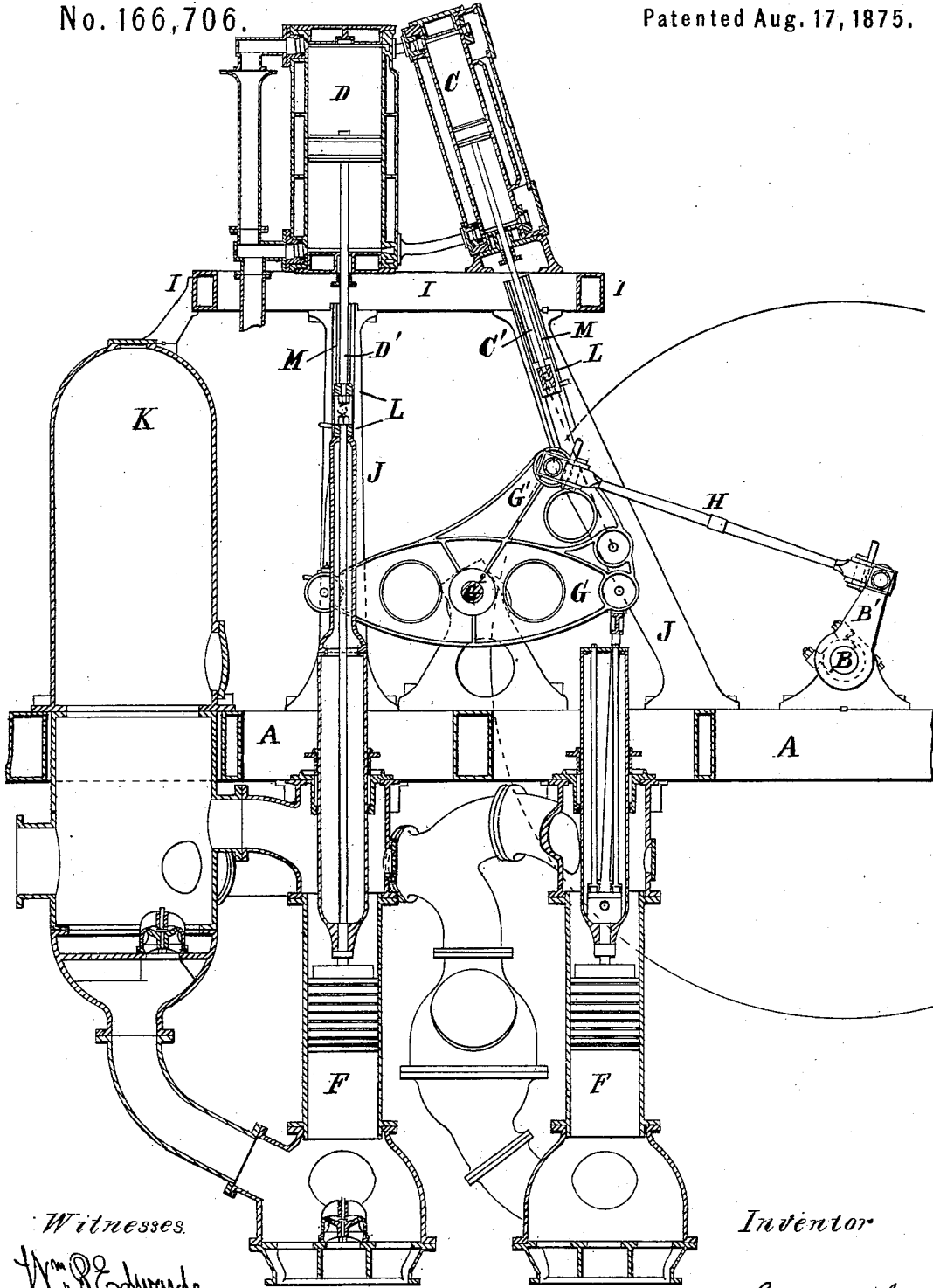

Witnesses

Wm. S. Edwards

Wm. G. Hibbard

Inventor

E. D. Leavitt, Jr.

Fig. 1.

E. D. LEAVITT, Jr.
Steam-Engines.

No. 166,706.

Patented Aug. 17, 1875.

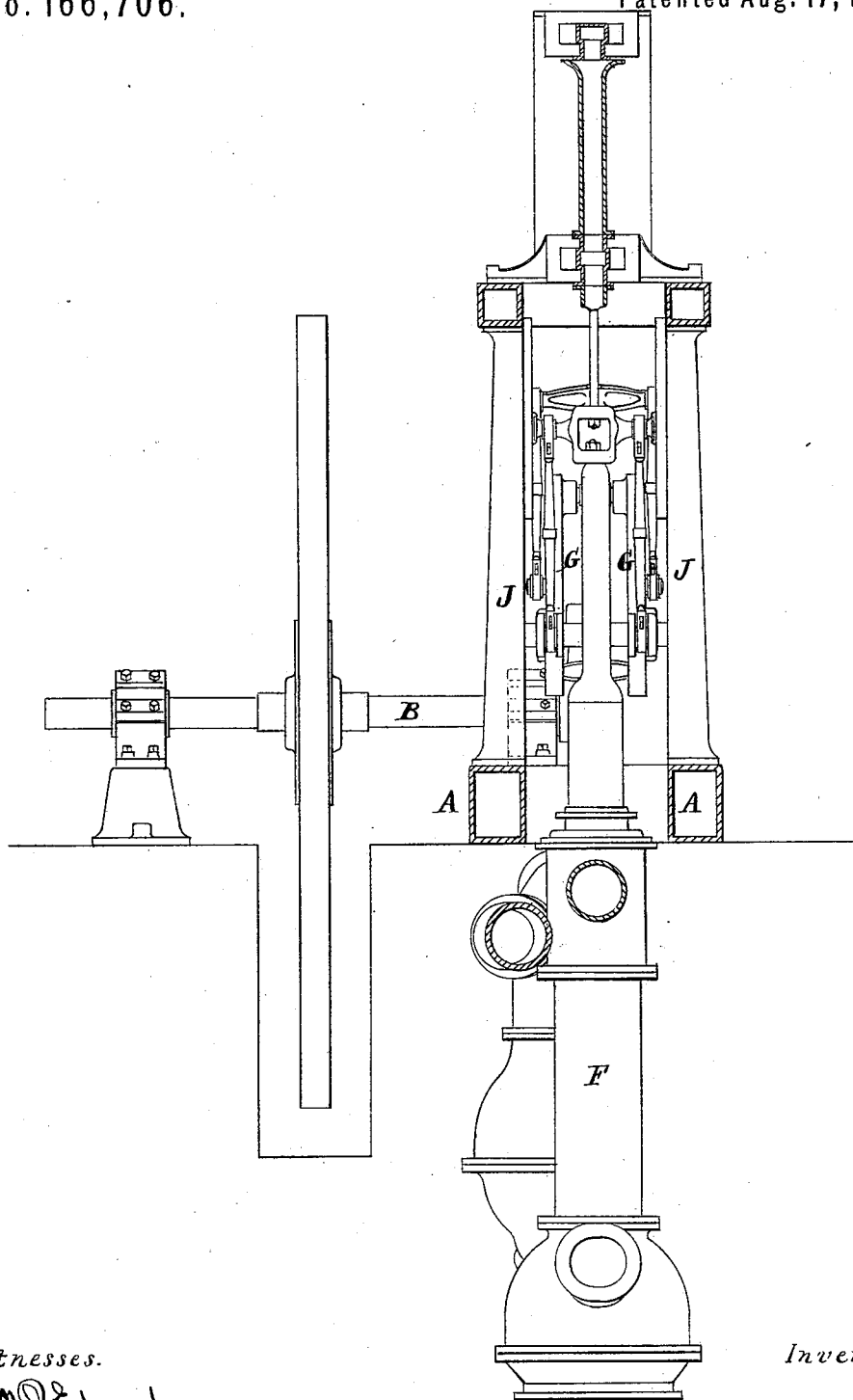

Witnesses.
Wm. J. Edwards
Wm. Hibbard

Fig. 2.

Inventor.
E. D. Leavitt, Jr.

E. D. LEAVITT, Jr.
Steam-Engines.

No. 166,706.

Patented Aug. 17, 1875.

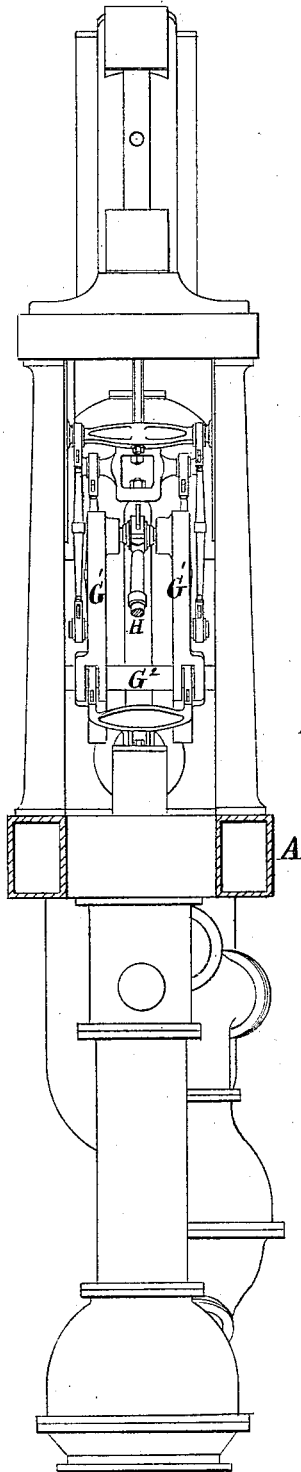

Witnesses.

Wm. B. Edwards
Wm. C. Hibbard

Fig. 3.

Inventor.

E. D. Leavitt Jr.

UNITED STATES PATENT OFFICE

ERASMUS D. LEAVITT, JR., OF CAMBRIDGE, MASSACHUSETTS.

IMPROVEMENT IN STEAM-ENGINES.

Specification forming part of Letters Patent No. **166,706**, dated August 17, 1875; application filed July 24, 1875.

To all whom it may concern:

Be it known that I, ERASMUS D. LEAVITT, Jr., of Cambridge, in the county of Middlesex and State of Massachusetts, have invented certain Improvements in the Construction of Steam-Engines, of which the following is a specification:

My invention relates to certain improvements in the construction and arrangement of certain parts of compound pumping-engines, so called, or an engine having a high-pressure and a low-pressure cylinder working in combination, by which arrangement greater stability and convenience are given to the machine at less expense than by the modes of construction before practiced.

The machine herein described has a general mode of operation similar to that described in Letters Patent of the United States granted to me July 16, 1872, No. 129,240, some of the parts of which are substantially repeated in the machine described in this application. These improvements may also be applied to compound engines for other purposes with similar advantage.

The main purpose of this construction is to enable the more important moving parts of the machine, such as have to withstand the greatest shocks and strains, to be placed below the cylinders and near the bed-plate, by which much less strength is required in the framing and foundation, and two pumps also may be worked from the same working-beam, in the same horizontal space that would be required if one only were used. The steam-cylinders are set inclined to each other, with their back ends upward, and placed close together, with their axial lines diverging, so as to intersect with the opposite ends of the working-beam, as in my said Patent No. 129,240, and for the reasons there stated. The working-beam axis is near the bed-plate, and the main shaft is placed upon the bed-plate in nearly the usual position, and the connecting-rod that leads to the beam is inclined upward, and connects with a journal upon an upper arm of the working-beam, in the proper position to receive it. The pump or pumps, as the case may be, are suspended from the under side of the bed-plate, and worked from the ends of the working-beam, and below them.

In the drawings, Figure 1 is a sectional elevation through the center of the cylinders and pumps. Fig. 2 is a sectional elevation looking toward the main shaft, and Fig. 3 is a sectional elevation looking toward the opposite end.

A is the bed-plate; B, the main shaft; B', the crank; C, the high-pressure cylinder; D, the low-pressure cylinder; F F', the pumps; G, the working-beam, and H the main connecting-rod, the details of which parts may be constructed substantially as has been before done. The connecting-rod H works upon a pin in the outer end of the arm G¹ of the working-beam, as shown, to determine the length of the stroke. The cylinders C D are mounted upon the entablature I of the framing, which is supported by the columns J and the top of the air-vessel K, or in any other suitable manner. The low-pressure cylinder D is placed vertical, and the high-pressure cylinder C is set inclined, and both in such relation to each other and to the working-beam G that their axes are in line to connect properly with each end of the beam. Both piston-rods C' D' project downward from the cylinders, and the working-beam center G² is near the bed-plate. The beam is made in two parts, with a space between them to receive the pump-rods and main connecting-rod. The general arrangement of the mechanism which connects the beam with the cylinders and with the pumps is more clearly shown in Figs. 2 and 3.

As the construction of the pumps forms no part of the present invention they will not be more particularly described, except so far as to show their connection with the other machinery as modified by my improvements.

The cylinder D is set vertically over one of the pumps, and if one pump only is to be used, it is probably the best way to construct, in which case the other pump and its accessories would not be used, and the foundations of the engine would be modified accordingly. The same arrangement of the cylinders, working-beam, and main shaft could also be used without the pumps and accessories to supply power to machinery; and this arrangement could be further modified, to reduce the height of the machine, by placing the working-beam lower and nearer the bed-plate, with the arm G¹ of

the beam for the connecting-rod projecting downward, and that rod inclined downward from the crank instead of upward, as shown.

By this arrangement of the several principal parts of the machine and the framing, all lateral strains upon the framing are avoided, and it can consequently be made much lighter than is usual, as well as the foundation, and have sufficient strength. It will also be observed that with this arrangement of the framing the main strains of the machine are exerted in a line with the columns of the framing and bed-plate, which gives a maximum of strength for the amount of material used.

In Figs. 2 and 3, the connections of the cylinders with the working-beam are shown, and also the connections of the same with the pumps, which are arranged differently at each end of the working-beam, to accommodate the main connecting-rod H, when worked in the position shown. L L are the cross-heads, and M M are the guides for the same, which are attached directly to the columns of the framing.

The valve-gear of the cylinders, as well as the condensing apparatus, are omitted in the drawings, and are to be constructed and operated substantially as is described in my said

Patent No. 129,240, and will not be further described, as they form no part of my present invention.

What I claim is—

1. The combination and arrangement of the high and low pressure cylinders, set above the beam, with their back ends near together, and inclined outward, so as to connect with opposite ends of the beam, the beam provided with an arm extending laterally therefrom above or below it, to receive the main connecting-rod, the crank-shaft, and fly-wheel, placed at nearly the height of the beam, and beyond the end thereof, all co-operating substantially as described.

2. The combination and arrangement of the high and low pressure cylinders, set above the beam, and connected with it as described, the crank-shaft and fly-wheel arranged and connected as described, and the two pumps connected with opposite ends of the beam, and placed below the same, substantially as described.

Executed July 20, 1875.

E. D. LEAVITT, JR.

Witnesses:

WM. P. EDWARDS,

WM. C. HIBBARD.