

J. GOULDING.
Steam-Generator.

No. 166,768.

Patented Aug. 17, 1875.

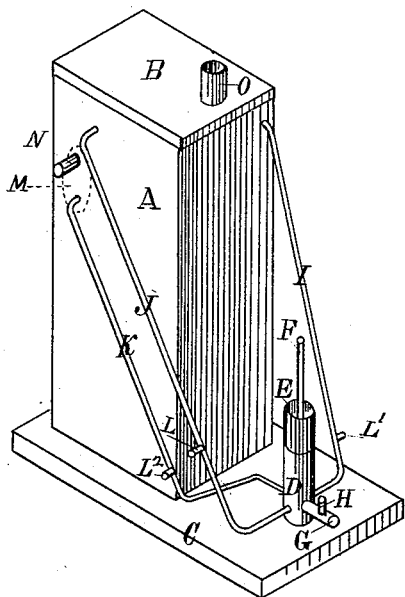

Fig. 1.

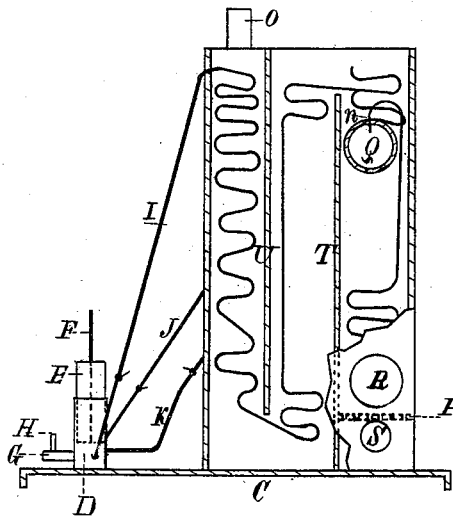

Fig. 2.

Witnesses;
Levels Shaw
H. E. Metcalf

Inventor;
John Goulding,
Per C. A. Shaw,
Atty.

UNITED STATES PATENT OFFICE.

JOHN GOULDING, OF WORCESTER, MASSACHUSETTS.

IMPROVEMENT IN STEAM-GENERATORS.

Specification forming part of Letters Patent No. **166,768**, dated August 17, 1875; application filed July 6, 1875.

To all whom it may concern:

Be it known that I, JOHN GOULDING, of Worcester, in the county of Worcester, State of Massachusetts, have invented a certain new and useful Improvement in Steam-Generators, of which the following is a description sufficiently full, clear, and exact to enable any person skilled in the art or science to which my invention appertains to make and use the same, reference being had to the accompanying drawing forming a part of this specification, in which—

Figure 1 is an isometrical perspective view, and Fig. 2 a vertical longitudinal section.

Like letters of reference indicate corresponding parts in the different figures of the drawing.

My invention relates to that class of steam-generators in which the feed-water pipes pass through the fire-pot or furnace on their way from the pump to the boiler or steam-chamber; and consists in a novel construction and arrangement of the parts, as hereinafter more fully set forth and claimed, by which a simpler, cheaper, and more effective device of this character is produced than is now in ordinary use.

The nature and operation of my improvement will be readily obvious to all conversant with such matters from the following description.

In the drawing, A represents the body of the furnace or fire-pot, and B the top of the same, which is provided with the funnel or smoke-pipe O. The body is divided vertically into three compartments by means of the partitions U T. The partition U extends from the top O nearly to the bottom, and the partition T from the bottom nearly to the top of the furnace, thus leaving flues under and over the same, respectively. A grate, P, is disposed near the bottom of one of the side compartments, on which the fire is placed, and near the top of the same compartment, immediately over the fire, there is a boiler or steam-chamber, Q, which does not entirely fill the compartment laterally, but leaves a space at either side for the passage of the smoke and other products of combustion, and also to admit a pipe, as hereinafter described.

A pump, D F E, provided with a suction or induction pipe, G, and having the stop-cock H, is disposed near the furnace A, and leading from this pump there is a main feed-water pipe, I, which passes into the furnace at the top of the outer compartment formed by the partition U, thence downwardly under said partition, thence upwardly between the partitions U T, thence downwardly, by the side of the chamber Q, into the outer compartment formed by the partition T over the fire on the grate P, thence, returning, enters said chamber near the top of the same. The pipe I is provided with a stop-cock, L¹, conveniently located near the pump D, and there is also an auxiliary feed-water pipe, J, connected with the pump and provided with a stop-cock, L. The pipe J passes into the furnace directly over the chamber Q, and is coupled to the pipe I. There is also a water exhaust or pipe, K, provided with the stop-cock L², connecting the pump D with the lower part of the chamber Q at M.

In the use of my improvement a fire is placed on the grate P, the cocks L L² being closed and the cock L¹ opened. Power is then applied to the pump, forcing water through the pipe I, which, as it passes the compartments formed by the partitions U T, will be converted into steam and discharged into the chamber Q, from which it is taken through the eduction-pipe N.

In case the water is not wholly converted into steam before reaching the chamber, and collects therein to an extent which is undesirable, the feed-pipe I may be closed and the chamber pumped out through the pipe K, the water so withdrawn being returned through the pipe J, to be additionally heated or converted into steam and discharged into the chamber, it being understood that the valves of the various pipes and the pump are properly constructed and arranged so as to admit of this.

The funnel or chimney O is located immediately over the compartment formed by the partition U, and hence it will be seen that the products of combustion, in passing from the grate to the funnel, move in a direction opposite to the feed-water entering the furnace,

which I have found to greatly facilitate the heating of the same.

Having thus explained my improvement, what I claim is—

In a steam-generator, the combination of the furnace A, provided with the partitions U T, the pump D, pipes I J K, and steam-

chamber Q, constructed and arranged to operate substantially as set forth and specified.

JOHN GOULDING. [L. S.]

Witnesses:

JONA. LUTHER, [L. S.]

H. L. PARKER. [L. S.]