

T. J. HARPER.
Sewing-Machine.

No. 166,869.

Patented Aug. 17, 1875.

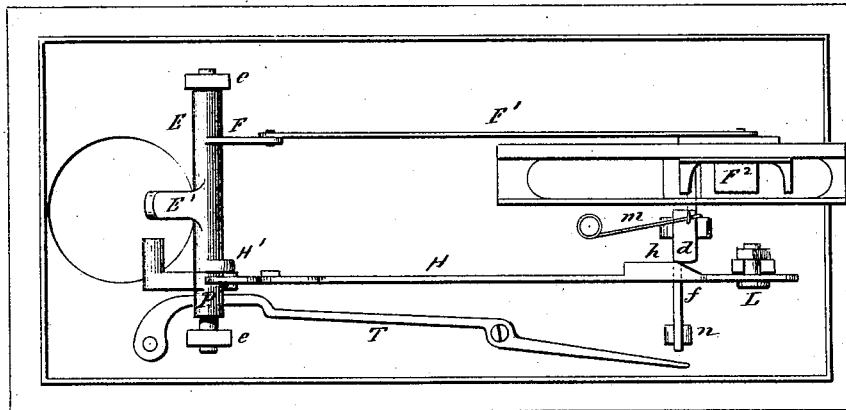
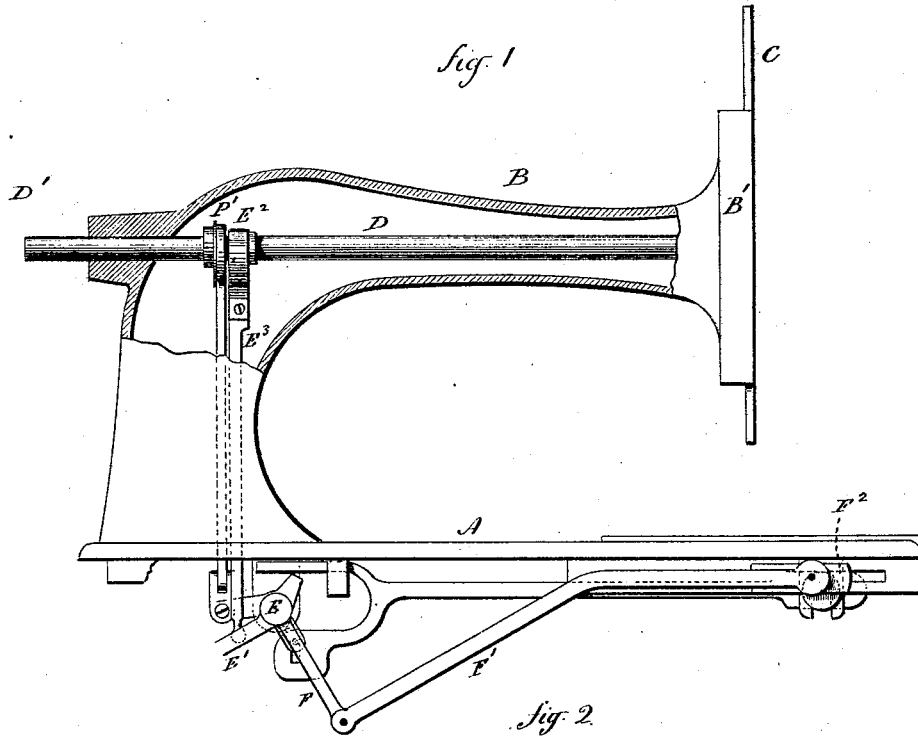

Witnesses:

H. Shumway
Clara Broughton

Thos. J. Harper
Inventor

By Atty.
John S. Earle

T. J. HARPER.
Sewing-Machine.

No. 166,869.

Patented Aug. 17, 1875.

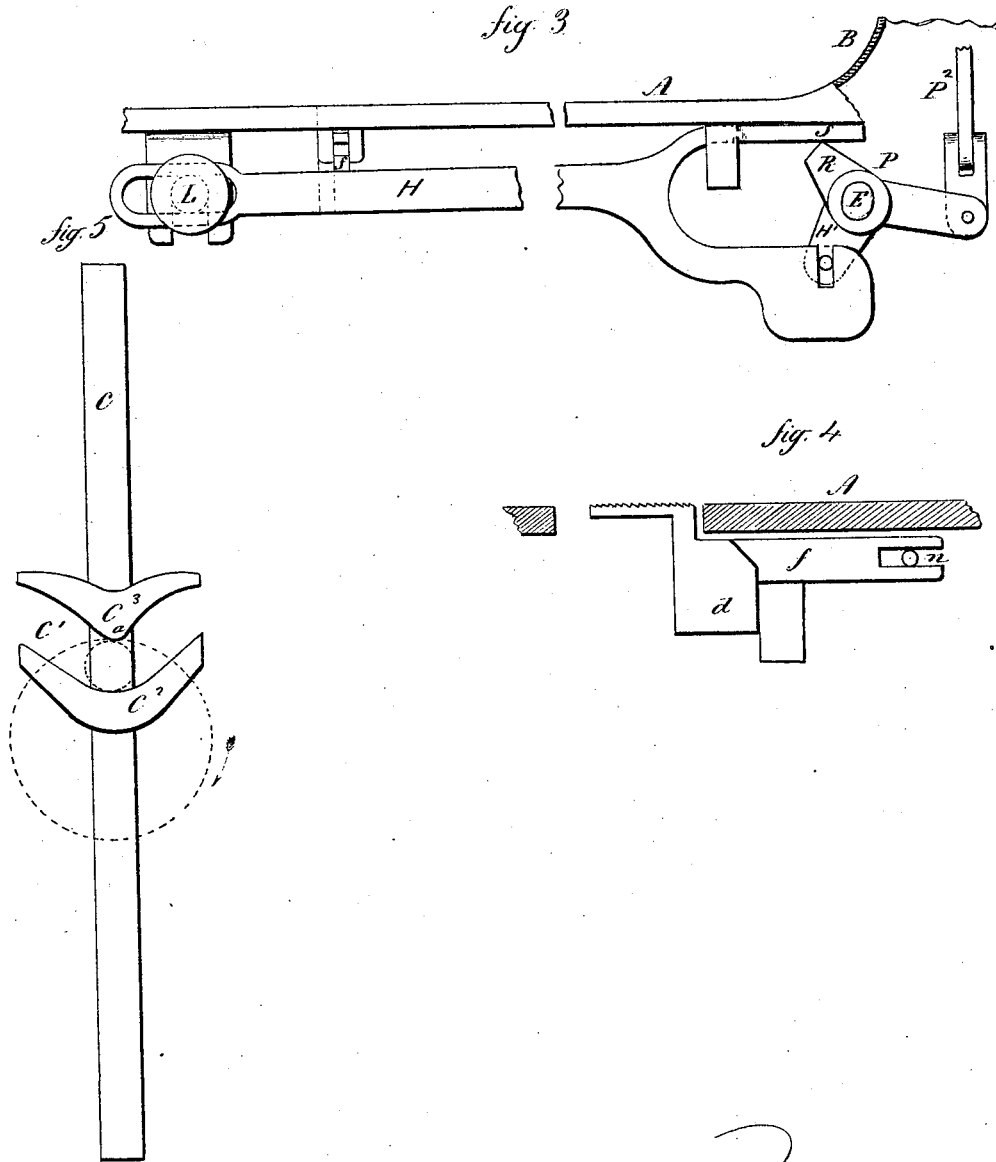

Witnesses:
A. S. Sumner
Clara Broughton

Thos. J. Harper
 Inventor
 By Atty.
John S. Earle

UNITED STATES PATENT OFFICE

THOMAS J. HARPER, OF ATLANTA, GEORGIA.

IMPROVEMENT IN SEWING-MACHINES.

Specification forming part of Letters Patent No. **166,869**, dated August 17, 1875; application filed June 11, 1875.

To all whom it may concern:

Be it known that I, T. J. HARPER, of Atlanta, in the county of Fulton and State of Georgia, have invented a new Improvement in Sewing-Machines; and I do hereby declare the following, when taken in connection with the accompanying drawings and the letters of reference marked thereon, to be a full, clear, and exact description of the same, and which said drawings constitute part of this specification, and represent, in—

Figure 1, sectional side view, with a portion of the needle-arm removed; Fig. 2, under-side view, looking up; Figs. 3, 4, 5, detached views.

This invention relates to an improvement in that class of sewing-machines in which the needle-bar has imparted to it a vertical reciprocating movement from a horizontal shaft.

In this class of machines the usual method of communicating movement to the different parts from a single driving-shaft has been by means of cams, which make the machines more or less noisy in their operation.

The object of this invention is to avoid the use of such cams or gearing; and it consists in combining, with the said rock-shaft, a lever which receives reciprocating movement from the oscillation of the rock-shaft, and combined with a second rock-shaft, caused to oscillate by an eccentric on the driving-shaft, and impart a vibratory movement to the said lever, which, combined with the reciprocating movement, imparts to the feed the necessary four-motion.

A is the work-plate; B, the needle-arm, constructed with the head B', and in which the needle-bar C is arranged, and vertically guided in substantially the usual manner for this class of machines. D is the driving-shaft, arranged in suitable bearings in the arm B, and caused to revolve by the application of power thereto through the pulley D'. On the end of this shaft, and within the head, is a crank. (Represented in broken lines in Fig. 5.) The needle-bar is constructed with arms C² and C³, which form a groove, C¹, within which the crank-pin works, as denoted in said Fig. 5. As the crank revolves it works from end to end of this groove, its highest elevation denoted in Fig. 5, and thus imparts an easy reciprocating movement to the needle-bar. Beneath the table is

a transverse rock-shaft, E, supported in bearings e, and from which an arm, E¹, extends rearward. On the driving-shaft is an eccentric, E², from which a rod, E³, connects with the arm E¹ by a ball-and-socket or other suitable joint; therefore, by the revolution of the shaft D, an oscillating movement is imparted to the rock-shaft E, substantially such as that imparted by a crank. From the rock-shaft E a second arm, F, projects, which is connected by a rod, F¹, to the shuttle-driver F². This imparts to the shuttle an easy, regular reciprocation, which is adjusted by the eccentric to the proper relative time, that the shuttle may engage the loop of the needle. H is the feed-lever, to which a reciprocating movement is imparted by a third arm, H', on the shaft E. The forward end of this lever H is supported on a stationary fulcrum, L, but the lever slotted, as seen in Fig. 3, so as to move longitudinally on the said fulcrum, and on the side of this lever is a cam or incline, h, which works against a projection, d, on the feed-bar f, the outer end of the said feed-bar supported on a fulcrum, n, and the bar resting on the lever, as denoted in Figs. 2, 3, and 4. Hence, when the lever H is forced forward, as in Fig. 2, the incline h will have forced the feed forward to its extreme position; but when the lever H returns, then the feed will fall back by the force of the spring m. Thus is imparted to the feed, at each revolution of the driving-shaft, a forward-and-back movement. To give the feed the necessary up-and-down movement, a sleeve, P, is arranged on the shaft E, so as to turn independent of the shaft, or may be an independent rock-shaft, and is actuated by an eccentric, P¹, on the driving-shaft through a rod, P², which imparts to the sleeve P an oscillating movement independent of the rock-shaft E, and on this sleeve is a projecting arm or cam, R, which works beneath an arm, s, on the lever H, so as to raise that end of the lever when turned as denoted in Fig. 3, or lower it when turned as denoted in broken lines. Such raising and lowering of the lever H imparts to the feed-bar which rests thereon a corresponding movement, and this raising and lowering is timed, relatively to the movement of the needle, in substantially the usual manner for four-motion feed.

The feed is adjusted by the lever T, which allows the feed to return against its end, and there be arrested, such return being varied by turning the said lever toward or from the feed.

I do not wish to be understood as claiming any of the elements shown and described, except as hereinafter specified.

I claim—

The combination, in a sewing-machine, of the driving-shaft D, the vertically-guided needle-bar C, the eccentrics E² and P¹ on said driving-shaft, the two rock-shafts E and P,

connected independently to the said eccentrics, and carrying, respectively, arms H' and R, with the feed-lever H, hung upon a fulcrum, L, forward of the feed-bar, and extending back to, and in connection with, the said arms H' and R, whereby it receives a combined reciprocating and vertical vibratory movement, and the feed-bar f, all substantially as specified.

THOMAS J. HARPER.

Witnesses:

J. B. BRIDGES,
GEO. C. DOUGLAS.