

W. LANNAN.  
Car-Coupling.

Patented Aug. 17, 1875.

No. 166,879.

Fig. 1.

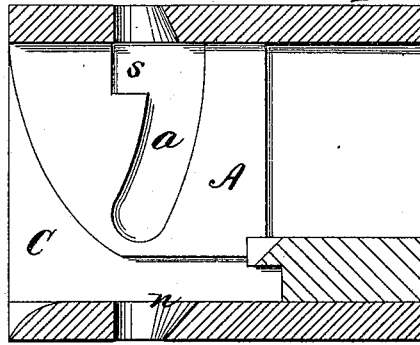

Fig. 2.

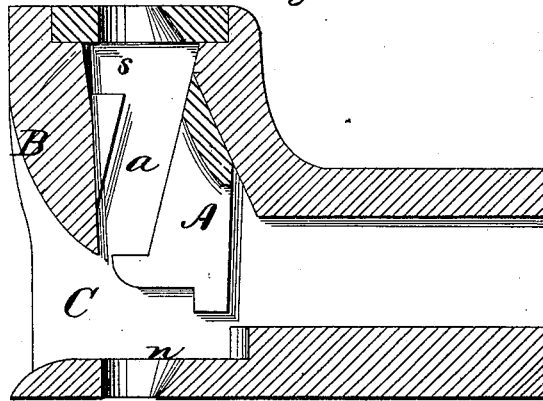
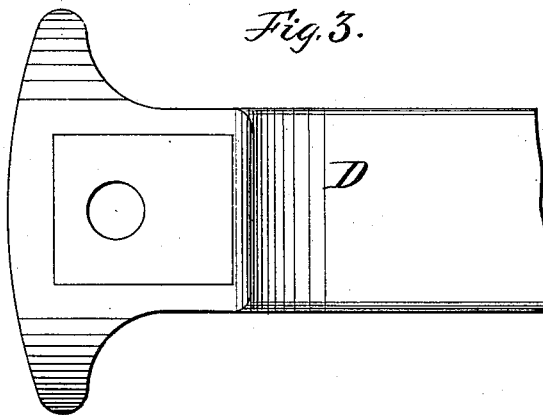

Fig. 3.



WITNESSES

*H. Church*  
*Ed. Harner.* .By

INVENTOR

*Wm Lannan*  
*Hill & Yellowth*  
*His Attorneys.*

W. LANNAN.  
Car-Coupling.

No. 166,879.

Fig. 4.

Patented Aug. 17, 1875.

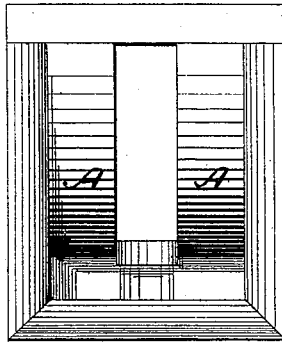

Fig. 5.

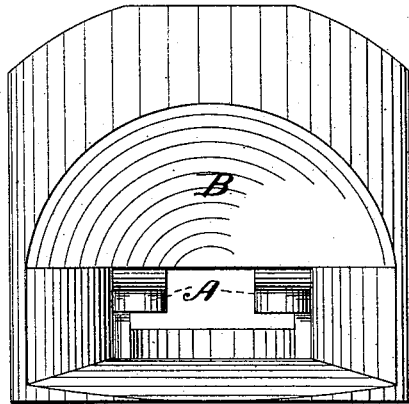
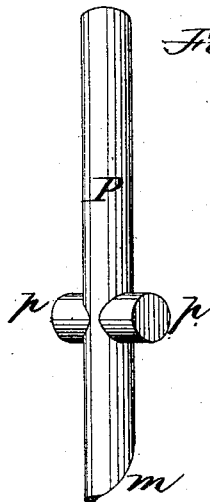

Fig. 6.



WITNESSES

*Wm. Kenny*  
*N. Church* By

INVENTOR

*Wm. Lannan*  
*Hill Yellworth*  
His Attorneys.

# UNITED STATES PATENT OFFICE.

WILLIAM LANNAN, OF UNION BRIDGE, MARYLAND.

## IMPROVEMENT IN CAR-COUPPLINGS.

Specification forming part of Letters Patent No. **166,879**, dated August 17, 1875; application filed July 21, 1875.

*To all whom it may concern:*

Be it known that I, WILLIAM LANNAN, of Union Bridge, in the county of Carroll and State of Maryland, have invented certain new and useful Improvements in Car-Couplings; and I do hereby declare the following to be a full, clear, and exact description of the same, reference being had to the accompanying drawings forming part of this specification, in which—

Figures 1 and 2 are longitudinal vertical sections, representing different modes of applying the principle of my invention. Fig. 3 is a top plan view of the draw-head. Figs. 4 and 5 are front elevations of different forms of draw-heads, and Fig. 6 is a perspective view of the coupling-pin.

Similar letters of reference in the accompanying drawings denote the same parts.

This invention is a further improvement upon the automatic car-coupling originally patented by William H. Gruver, December 22, 1874, No. 158,064, and afterward improved by Joel Miller, as shown in his patent dated June 1, 1875, No. 164,020; and it consists in the application of an improved form of coupling-pin, and new and improved devices for supporting, guiding, and holding said pin, which greatly simplify the construction of the coupling, reduce the expense of its manufacture, and increase its durability and general efficiency.

In the drawings, D represents the draw-head, provided with the usual longitudinal cavity C, terminating at its front end in a flaring mouth, B, for the purpose of causing the link to enter properly when coupling. On each side of the interior cavity a block or lugs, A, is cast or otherwise properly secured to the inner sides of the draw-head, the proximate faces of the blocks coming so near together as just to allow sufficient space for the easy working of the coupling-pin, and not extending down far enough to prevent the entering of the link which works in the space beneath. Each block is provided with a groove or recess, *a*, extending from the upper end of the block downward and forward nearly to the lower end; and near the upper end of said groove or recess a shoulder, *s*, is formed, as shown. The coupling-pin P is formed in the

shape of a cross, its two arms, *p p*, projecting into the grooves *a a* for the purpose of properly supporting it and guiding its movements. The lower end of the pin is beveled on its rear side, as seen at *m*, and the lower pin-hole is correspondingly beveled on its rear upper edge, as represented at *n*. The upper end of the pin extends through the upper pin-hole, and may be attached to a chain, if preferred, for convenience of operating it from the platform of the car.

In coupling automatically with this improved device, the inner end of the link in one car is held between the lower end of the blocks A and the floor of the cavity C, so as to present the outer end of the link properly to the opposite draw-head. As the cars come together, if the coupling-pin is down, the end of the link strikes against it and slides its inclined end *m* backward and upward on the incline *n* until the link passes under it, when the pin drops into position and the cars are coupled. If the pin, on the other hand, is up when the cars come together, being supported by its arms resting on the shoulders *s s*, the entering-link knocks it off of the shoulders, and it falls and couples the cars automatically. As the groove *a* extends forward at its lower end the pin cannot work up out of place and uncouple the cars accidentally, but the draft upon it tends directly to keep it down to its work. The pin is supported against the draft of the link not only by the top and bottom of the draw-head, but by the side blocks A A, so that it is in little danger of giving way under any strain to which it may be exposed.

The coupling can be effected by hand in the ordinary manner whenever desirable, so that the invention unites in one device the advantages of two modes of automatic coupling, together with all the advantages of the old-fashioned link-and-pin coupling.

Each block A may be made in one or more parts, as preferred, and the form may be varied considerably from those here shown without departing from the principles of my invention.

In Fig. 2, where the front wall of groove *a* is formed by an independent inclined piece, the same principle is involved as in Fig. 1. So, also, the blocks A A may be formed by

simply casting projections of the proper shape or grooves of the proper shape on or in the side walls of the draw-head.

Having thus fully described my invention, I claim as new—

1. The coupling-pin P, having the cross-arms *p p*, and the lower end inclined or beveled at its rear edge, as shown at *m*, substantially as and for the purposes specified.
2. The blocks A, having the grooves *a a* inclined downward and forward, in combination

with the pin P, having cross-arms *p p*, substantially as and for the purposes set forth.

3. The blocks A, having the grooves *a a*, combined with the shoulders *s s* at the upper end of the grooves, and operating in combination with the pin P, as described, for the purposes specified.

WM. LANNAN.

Witnesses:

JESSE H. NUSSEAR,  
A. L. BEARD.