

P. HEILMAN & J. HEILMAN, Jr.

Dumping-Wagon.

No. 167,531.

Patented Sept. 7, 1875.

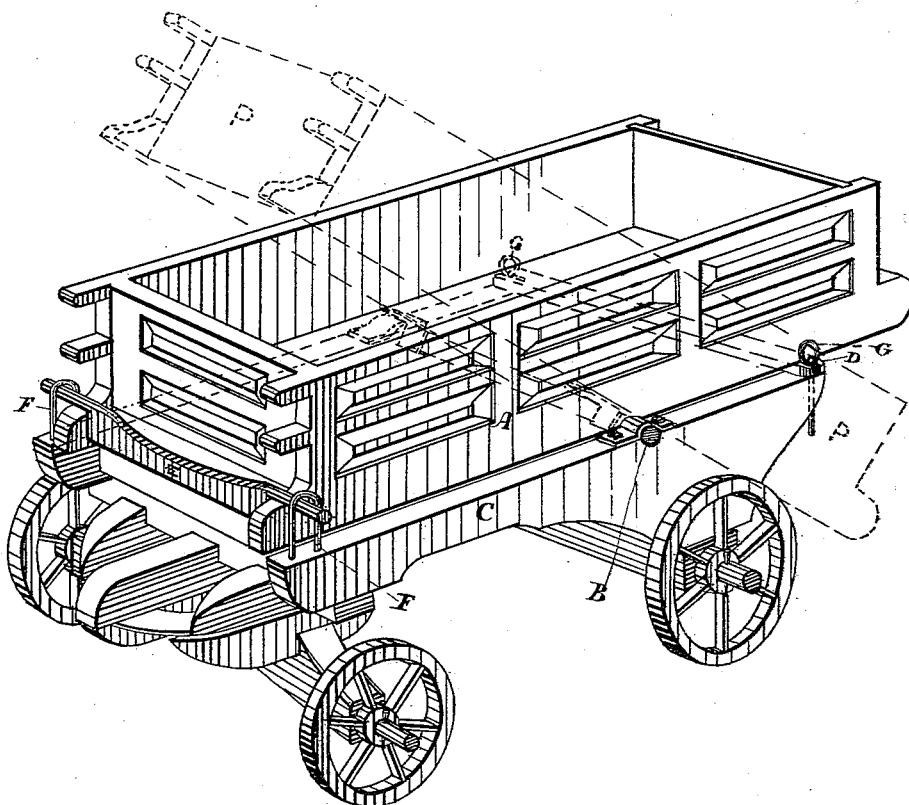

WITNESSES:

*N. Peters*  
*A. C. Miller*

INVENTORS:

*Philip Heilmann*  
*Jacob Heilmann, Jr.*  
*by John Swenson & Son Attys*

# UNITED STATES PATENT OFFICE.

PHILIPP HEILMAN AND JACOB HEILMAN, JR., OF TIFFIN, OHIO.

## IMPROVEMENT IN DUMPING-WAGONS.

Specification forming part of Letters Patent No. **167,531**, dated September 7, 1875; application filed May 24, 1875.

*To all whom it may concern:*

Be it known that we, PHILIPP HEILMAN and JACOB HEILMAN, Jr., of Tiffin, in the county of Seneca and State of Ohio, have invented a new and useful Improvement in Dumping-Wagons, of which we declare the following to be a full, clear, and exact description thereof, reference being had to the accompanying drawing, forming a part of this specification—

Figure 1 being a perspective view, showing the whole of the parts.

In order to enable others skilled in the art to which our invention appertains to make and use the same, we will now proceed to describe its construction and operation.

The wagon-box A is arranged to tip backward on a trunnion-shaft, which has bearings on the frame C C, which is composed of the parallel sills or bed-timbers C C, with suitable pieces to hold the same in position, said bed-timbers being so shaped and constructed as to entirely dispense with the hind bolster of the wagon, and is suitable for and can be attached to any ordinary wagon. The bed-frame is provided with bars D and E, secured by suitable pins G G and loops F, for relieving the trunnion-shaft from the weight of the

box when the latter is in a horizontal position. The dotted line P shows the position of the box when dumping its load. The box is made somewhat wider at its rear end, in order to allow the load to go easily from it.

The operation is as follows: Previous to dumping the rear bar D is removed; the front bar E is also removed from the loops F, and by lifting the front end, the load is discharged.

Having thus described the construction and operation of our said invention, what we claim, and wish to secure by Letters Patent, is—

The combination, in a dumping-wagon, of the box A, hung on trunnions B, with the sills or bed-frame timbers C C, the bars D and E in the front and rear ends, with the straight axle-trees, all as and for the purpose set forth.

In witness that we claim the foregoing we hereunto set our hands this 18th day of May, A. D. 1875.

PHILIPP HEILMAN.  
JACOB HEILMAN, JR.

In presence of—  
JOSEPH GUYMS,  
R. M. BOYER.