

W. FARMER.

Movable Dip-Pipe used in Gas-Making Apparatus.

No. 167,605.

Patented Sept. 14, 1875.

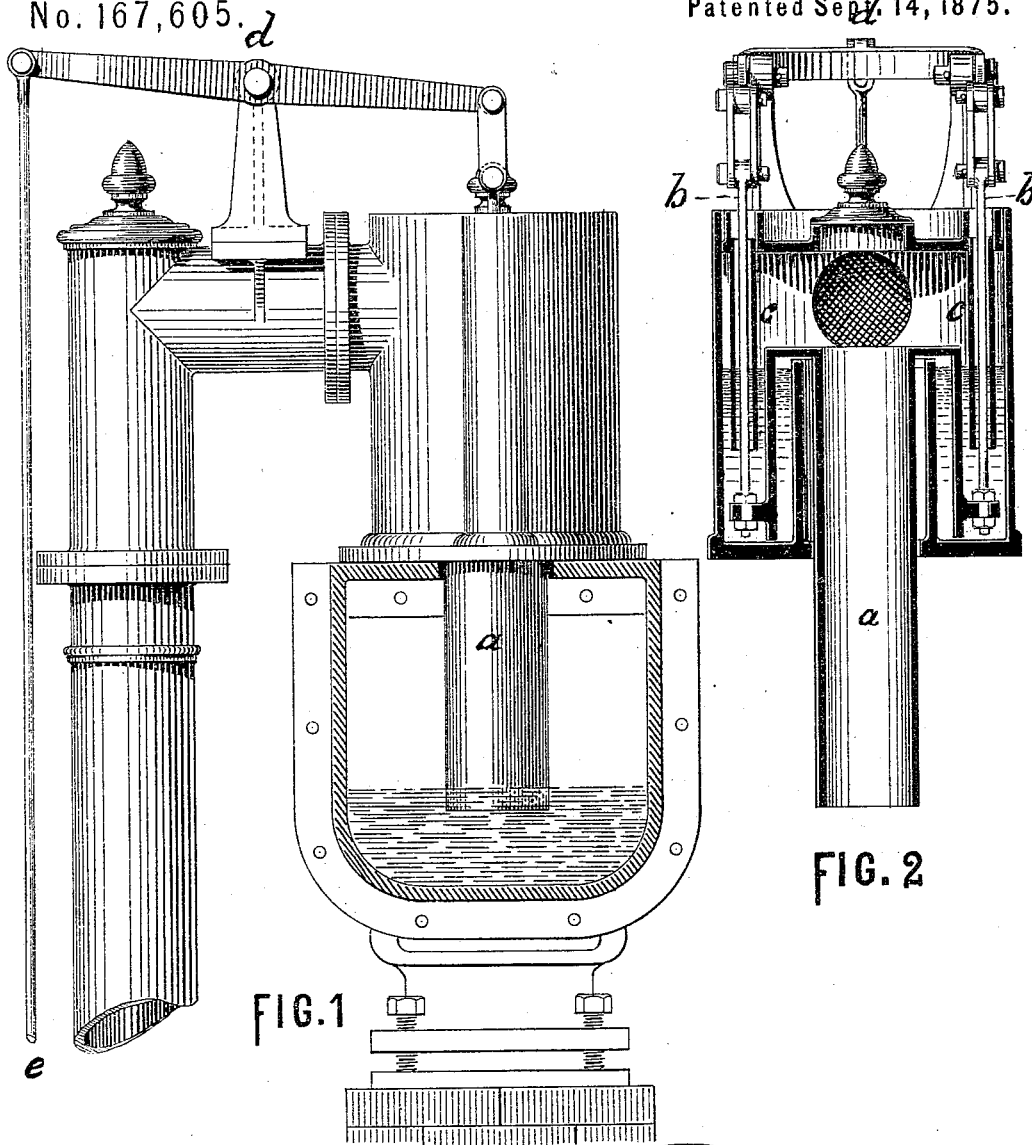

FIG. 1

FIG. 2

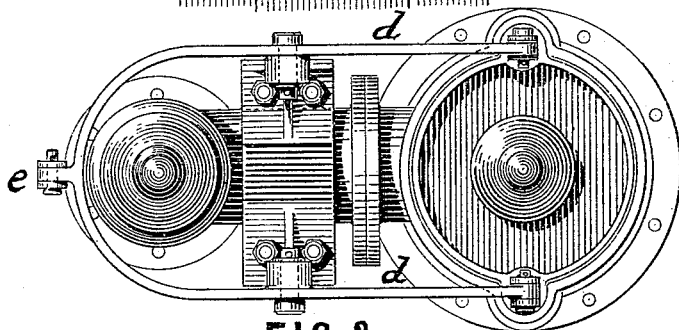

FIG. 3

WITNESSES

Wm. Hembel Hall
David C. Gwynne

INVENTOR

Wm. Farmer

W. FARMER.

Movable Dip-Pipe used in Gas-Making Apparatus.

No. 167,605.

Patented Sept. 14, 1875.

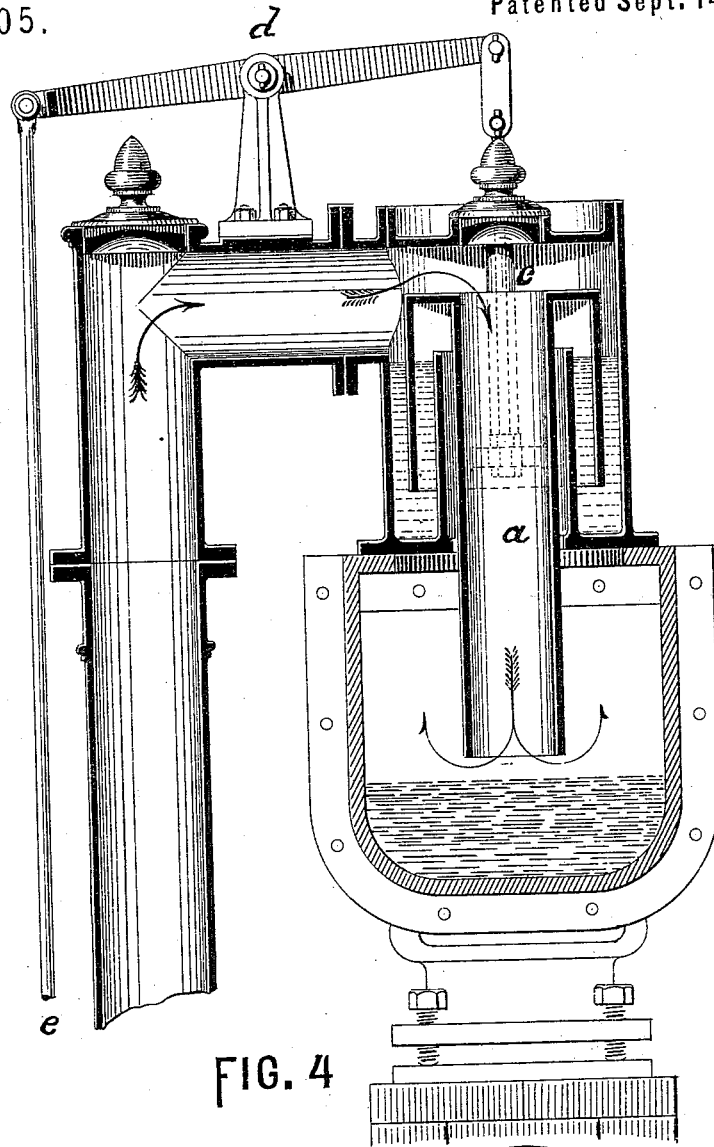

FIG. 4

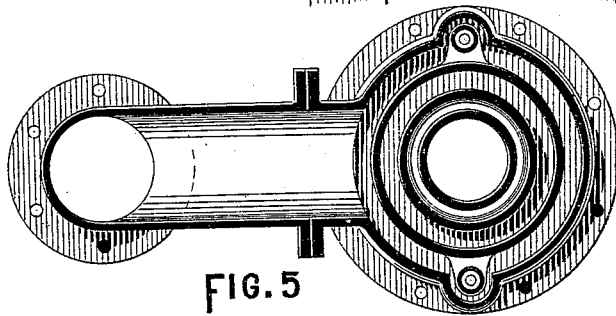

FIG. 5

WITNESSES

Wm Remble Hall.
David E. Gwynne.

INVENTOR

Wm Farmer

UNITED STATES PATENT OFFICE.

WILLIAM FARMER, OF NEW YORK, N. Y.

IMPROVEMENT IN MOVABLE DIP-PIPES USED IN GAS-MAKING APPARATUS.

Specification forming part of Letters Patent No. **167,605**, dated September 14, 1875; application filed August 23, 1875.

To all whom it may concern:

Be it known that I, WILLIAM FARMER, of New York, in the county and State of New York, have invented a certain new and useful Improvement in the Movable Dip-Pipes Used in Gas-Making Apparatus, of which the following is a specification:

In the movable dip-pipes that have been hitherto applied to gas-making apparatus for the purpose of relieving the retort when in operation from the pressure necessary to overcome the resistance of the seal in the hydraulic main, the pipe has been obstructed by the bale and rod or other means for its suspension, and it has been encumbered with a stuffing-box or a sealing-pipe in its interior for making a tight joint for its external connection with the means of operation.

My improvement consists in suspending a movable dip-pipe on rods that pass at the sides of the dip-pipe and outside of it, leaving its opening clear, through pipes that are sealed by the liquid provided for sealing the upper end of the dip-pipe. To effect this object suspending-rods from an external lever are bolted to lugs on each side of the dip-pipe below the surface of the upper seal, as ordinarily arranged, and a like number of pipes inclosing these rods are secured to the cover of the upper seal with their lower ends below the liquid, so that they are also sealed.

By this arrangement the interior of the dip-

pipe is left entirely free, and may be readily cleaned on the removal of its stopper, and it may be easily worked by a pendent handle to a lever attached to the rods by which it is suspended.

To enable others skilled in the arts to which it appertains to make and use my invention, I will proceed to describe its construction and operation with reference to the drawings.

Figures 1, 2, and 4 are an elevation and vertical sections of the apparatus; and Fig. 3 is a plan, and Fig. 5 a horizontal section, of the same.

The dip-pipe *a* is suspended by the rods *b* that are inclosed in the pipes *c*, that are sealed by the liquid in the upper seal. The lever *d*, to which the suspending-rods are hung by suitable links, has a handle, *e*, by which it may be balanced and worked, as required.

Figs. 1 and 2 show the dip-pipe depressed and sealed by the liquid in the hydraulic main, and Fig. 4 shows it raised for the free transmission of the gas from the retort.

I claim—

The combination of a movable dip-pipe with the suspending-rods *b* and the sealed pipes *c*, arranged substantially as described.

WM. FARMER.

Witnesses:

DAVID E. GWYNNE,
WM. KEMBLE HALL.