

A. BUGBEE.

Propelling Canal-Boats.

No. 167,641.

Patented Sept. 14, 1875.

Fig. 1.

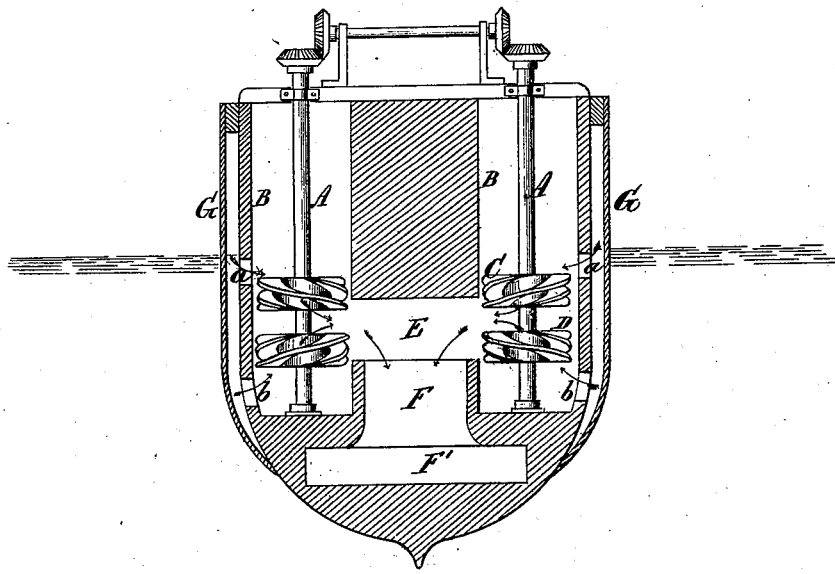

Fig. 2.

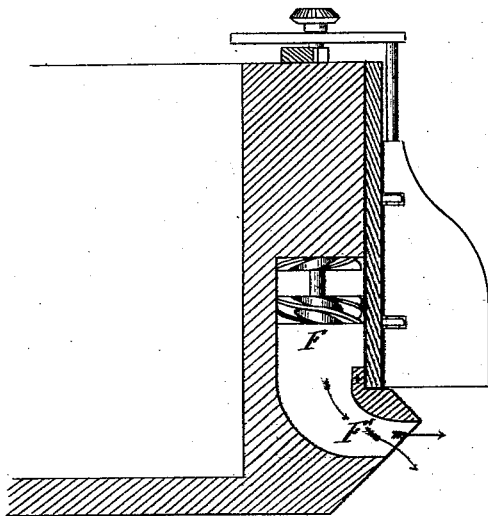
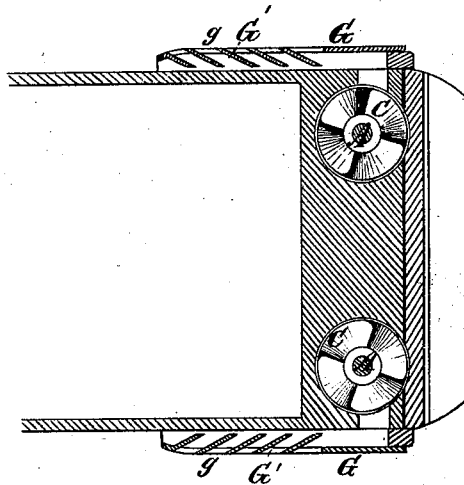

Fig. 3.



Witnesses.  
P. C. of C. S.  
A. Ruppert.

Inventor.  
Almond Bugbee

# UNITED STATES PATENT OFFICE.

ALMOND BUGBEE, OF SOUTH BEND, INDIANA.

## IMPROVEMENT IN PROPELLING CANAL-BOATS.

Specification forming part of Letters Patent No. **167,641**, dated September 14, 1875; application filed May 5, 1874.

### *To all whom it may concern:*

Be it known that I, ALMOND BUGBEE, residing at South Bend, in the county of St. Joseph and State of Indiana, have invented a certain Improvement in Propulsion of Vessels, of which the following is a specification:

This invention relates to that class of vessels which are propelled by streams or jets of water discharged from the stern of the vessel into the body of the water in which it is floating.

My improvement consists, first, in the employment of a pair of turbines, fastened to a vertical shaft some distance apart, with their curved buckets in reversed positions, and operating in a chamber in the stern of the vessel. Thus arranged, the upper turbine will take in the water above, and the lower one below, and both discharge it into the space between them, from which it issues with a force proportional to the velocity with which the turbines are rotated, the downward pressure of one wheel being compensated by the upward pressure of the other, so that the shaft or spindle supporting them will not be subjected to undue wear. My improvement consists, secondly, in the employment of racks upon the sides of the vessel, through the openings in which the water is drawn in by the turbines, said openings being divided by oblique plates to aid in propelling the vessel in the manner hereinafter more fully explained.

Fig. 1 is a transverse section through the stern of a vessel having my improved propelling mechanism attached. Fig. 2 is a longitudinal vertical section of the same. Fig. 3 is a sectional plan view thereof.

The same letters of reference are used in all the figures in the designation of identical parts.

In the example illustrated, two pairs of turbines are shown, one upon each side of the vessel, and this is the preferable mode of applying my invention in practice; but it is evident that one pair of turbines, placed centrally upon the boat and taking water from each side, may be made to answer in many cases.

Each pair of turbines is fastened upon a vertically-disposed spindle, A, which turns in a step upon the bottom of the cylindrical chamber B in the stern of the vessel, and which may be rotated by a steam-engine or other motor in any preferred manner.

The blades or buckets of the upper turbine C are disposed reversely to the buckets or blades of the lower turbine D, and the shaft A must be turned so as to cause the former to take the water in above through the induction-aperture *a*, and the latter to take in the water below through the induction-aperture *b*, both turbines discharging the water into the space between them, from which it escapes through the passage E into a central chamber or cavity, F, in the stern of the boat, and issues from that through the eduction-opening F' into the body of water in which the vessel floats.

Instead of taking in the water directly through the induction-apertures *a* and *b*, I prefer to cover said apertures by a rack, G, in the manner best illustrated in Fig. 3, and draw the water through that. This rack is constructed with a series of vertically-elongated openings, *g g*, which are divided from each other by the plates G'. The latter are arranged in oblique positions in the manner shown in Fig. 3, the effect of which will be to cause the ingoing currents of water to press upon these inclined planes, so as to assist, to some extent, in propelling the vessel.

In order to make this action of the water upon the oblique surfaces of the plates as effective as possible, the openings in the racks should correspond in area as nearly as possible with the area of the eduction-aperture. The turbines may be arranged horizontally, if preferred; and it should be stated that where they are to be used for propelling boats in shallow water the chamber in which they operate should be closed air-tight.

What I claim as my invention, and desire to secure by Letters Patent, is—

1. In combination with a vessel a pair of turbines, C and D, having their buckets arranged in reverse positions, induction-apertures *a* and *b*, and eduction-aperture F', substantially as and for the purpose set forth.

2. In combination with the elements enumerated in the first claim, the racks G with oblique plates G', substantially as and for the purpose specified.

In witness whereof I have signed my name this 30th day of March, 1872.

ALMOND BUGBEE.

Witnesses:

D. P. HOLLOWAY,  
B. EDWARD J. EILS.