

L. P. COHEN & I. FRANK.

Machine for Cutting Roll-Paper.

No. 167,645.

Patented Sept. 14, 1875.

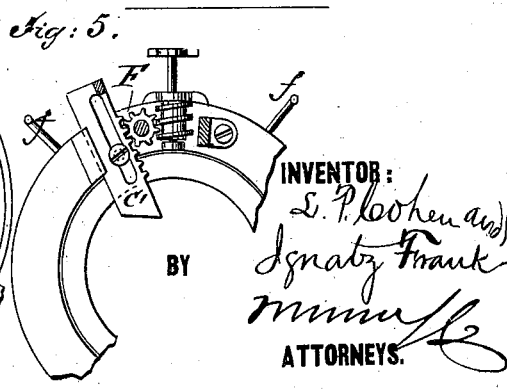
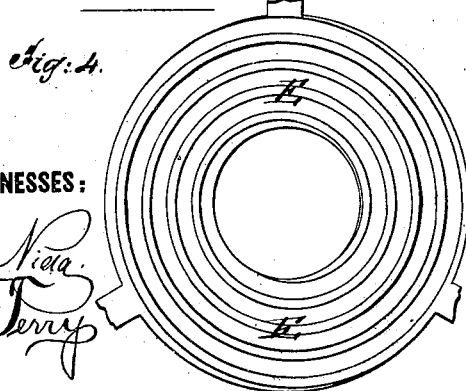
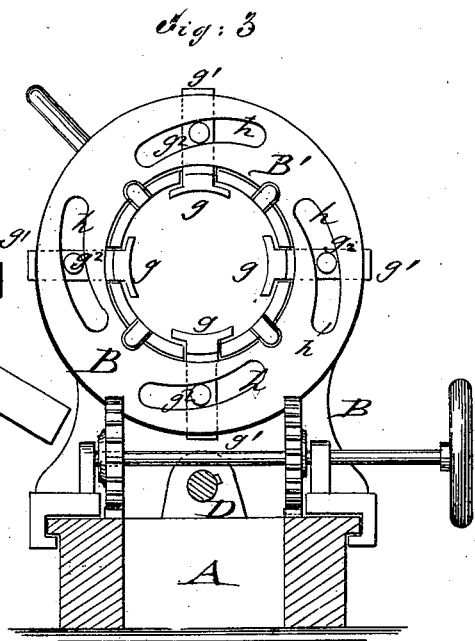
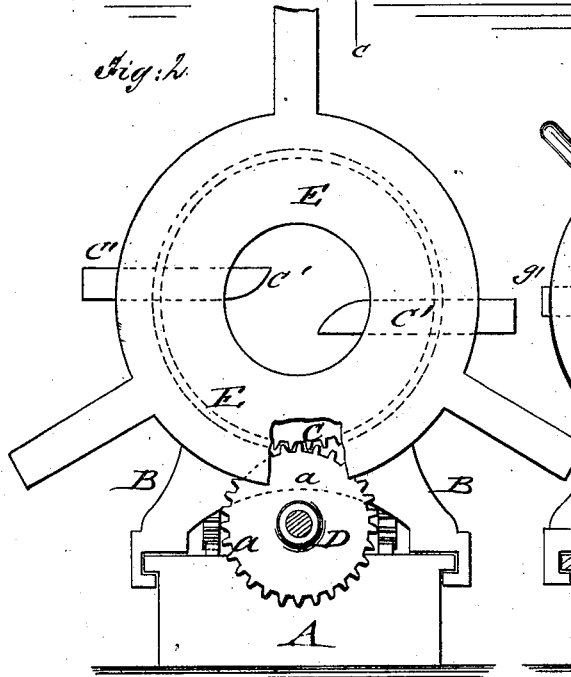
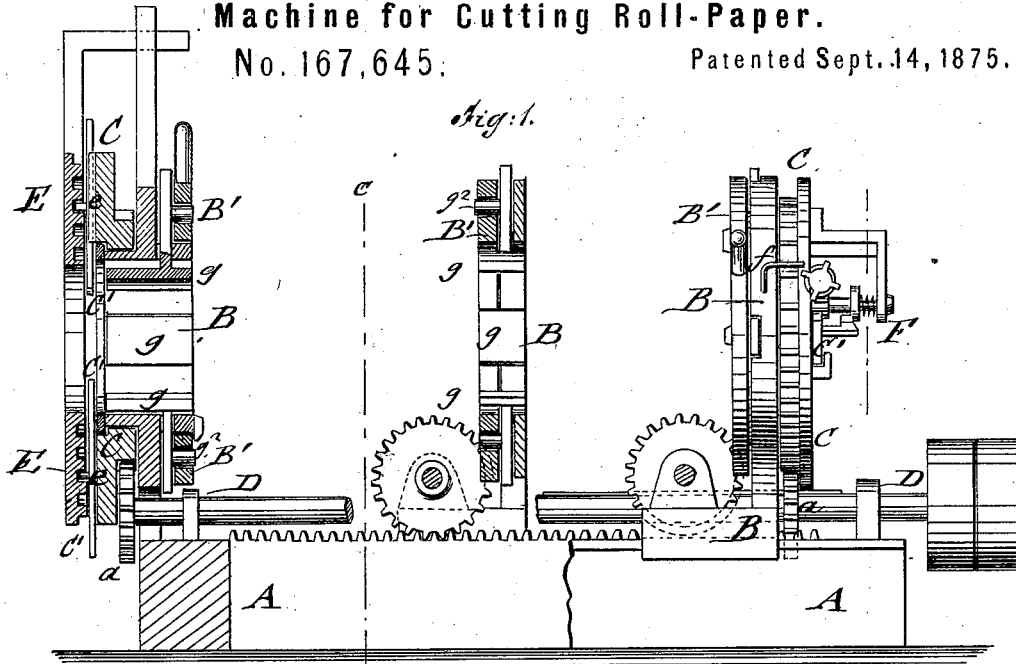

WITNESSES:

Chas. N. ...
A. J. ...

INVENTOR:

L. P. Cohen and
Ignatz Frank
BY *[Signature]*
ATTORNEYS.

UNITED STATES PATENT OFFICE.

LOUIS P. COHEN AND IGNATZ FRANK, OF NEW YORK, N. Y.

IMPROVEMENT IN MACHINES FOR CUTTING ROLL-PAPER.

Specification forming part of Letters Patent No. 167,645, dated September 14, 1875; application filed February 13, 1875.

To all whom it may concern:

Be it known that we, LOUIS P. COHEN and IGNATZ FRANK, of the city, county, and State of New York, have invented a new and Improved Machine for Cutting Roll-Papers, of which the following is a specification:

In the accompanying drawing, Figure 1 represents a sectional side elevation of our improved machine for cutting roll-papers; Fig. 2, an end view; Fig. 3, a vertical transverse section of the same on the line *c c*, Fig. 1; and Figs. 4 and 5, respectively, are detail views of two separate cutter-feeding mechanisms.

Similar letters of reference indicate corresponding parts.

Our invention relates to an improved machine for cutting rolls of any width directly from the roll-papers, for telegraph-rolls and other purposes; and it consists, mainly, of movable roll-clamping standards provided with one or more revolving ring-shaped heads carrying the cutting-knives that are fed forward simultaneously by suitable mechanisms.

In the drawings, A represents the base-frame of our roll-paper-cutting machine, which has longitudinal side racks for setting the movable intermediate and outer clamping-standards B and cutter-heads C into any desired position thereon, according to the length of the roll-paper to be cut. One end standard and cutter-head is made stationary, while the opposite and intermediate standards are set by base guide-pieces and cog-wheels in the usual manner. All the roll-clamping standards B may be provided with cutter-heads when it is desired to cut the roll at one operation into a number of smaller sections, or only the outer standards may be arranged with cutter-heads, as found most convenient. A central longitudinal shaft, D, which is driven by steam or other power in connection with suitable reversing-gear, transmits, by cog-wheels *a*, (which are keyed laterally by a longitudinal rib to the shaft, but made to slide thereon in longitudinal direction with the standards,) rotary motion to the ring-shaped cutter-heads C. One or more cutting-knives, C', are guided in suitable grooves of the heads, preferably two of them at diametrically opposite points, and in parallel but

nearly radial direction to the center of the head, and are fed forward for gradually cutting off a roll-section, either by means of a spirally-grooved disk-plate, E, which is applied stationary over the revolving head and engages projecting lugs *e* of the knives, as shown in Figs. 1 and 4, or by a gear-wheel mechanism, F, that is applied to the head, and is operated by the contact with stationary arms *f* of the standards, as shown in Fig. 5.

The spirally-grooved disk-plate seems to be preferable to the gear-wheel feed, but we do not confine ourselves to any special mechanism for feeding and returning the cutting-knives, as different constructions may be employed for the same purpose.

The ring-shaped standards B are arranged with arc-shaped clamping-shells *g*, which slide by radial arms or stems *g*¹ in corresponding grooves of the standards, and are operated by a loosening-plate, B', with handle part turning on annular guide-flanges and acting by eccentric slots *h* on pins or lugs *g*² of the sliding shell-stems, so as to adjust the whole series of them to the roll by one motion of the operating-ring.

The rolls are first inserted into the standards, the cutter-heads and intermediate standards then set into the required position, the clamping devices are next applied, and, by the revolving motion imparted to the cutter-heads, the forward feeding of the knives and the cutting off of disk-shaped rolls of any width is produced. The motion of the shaft is then reversed, and the knives moved back, the standards and clamps are readjusted, and the next sections cut off, and so on, accomplishing thereby the cutting off of paper rolls of narrower width for telegraph and other purposes with facility, economy, and rapidity, directly from the original rolls, without the process of winding and unwinding the paper in feeding it to the cutting-knife.

Having thus described our invention, we claim as new and desire to secure by Letters Patent—

1. A machine for cutting roll-paper into sections without unwinding, constructed of stationary and movable clamping-standards with

revolving cutter-heads and simultaneously feeding cutting-knives, the whole being arranged and operated substantially in the manner and for the purpose set forth.

2. The combination, with the ring-shaped roll-clamping standard, of a revolving cutter-head with one or more cutting-knives, feeding by suitable mechanism from the circumference

of the head toward the center, and back again on reversing the motion of the cutter-head, substantially as specified.

LOUIS P. COHEN.
IGNATZ FRANK.

Witnesses:

PAUL GOEPEL,
T. B. MOSHER.