

R. H. THOM.
Steam-Generator.

No. 167,711.

Patented Sept. 14, 1875.

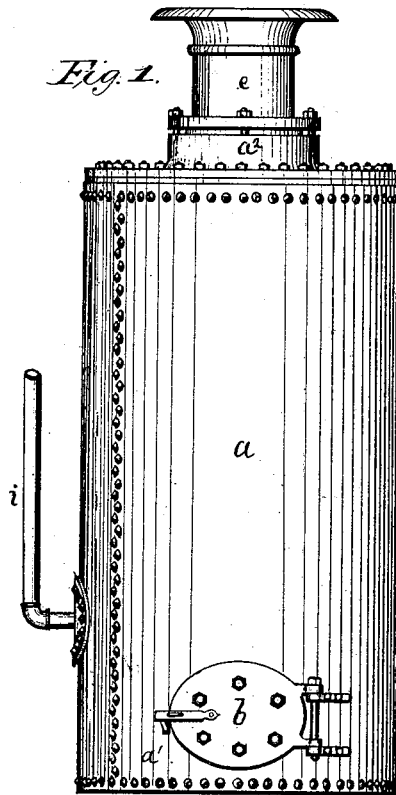
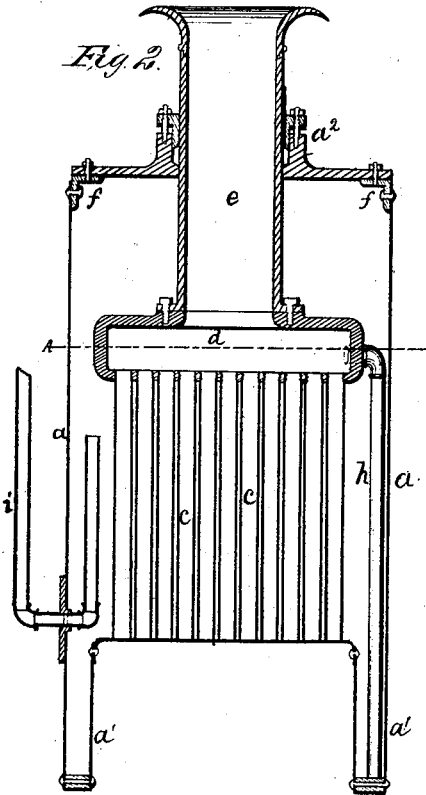
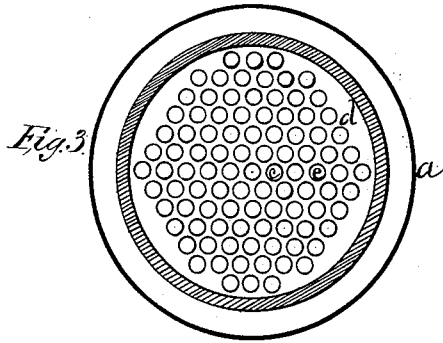

Witnesses:
William H. Davis,
John H. Forey

Inventor:
Royal H. Thom

UNITED STATES PATENT OFFICE.

ROYAL H. THOM, OF SYRACUSE, NEW YORK.

IMPROVEMENT IN STEAM-GENERATORS.

Specification forming part of Letters Patent No. **167,711**, dated September 14, 1875; application filed February 6, 1875.

To all whom it may concern:

Be it known that I, ROYAL H. THOM, of Syracuse, Onondaga county, New York, have invented certain Improvements in Steam-Generators, of which the following is a specification:

My improvements in steam-generators are intended to cheapen their manufacture and render the tubes and other joints more durable, avoiding thereby all undue strains upon them from expansion and contraction, while from the formation and combination of the parts a rapid and efficient generation of steam is insured.

The construction is as follows, referring to the accompanying drawing, in which—

Figure 1 is an exterior elevation. Fig. 2 is a vertical section through the center of the generator. Fig. 3 is a horizontal section on the line A, Fig. 2.

The shell *a* of the generator, as shown in the drawing, is cylindrical, although that particular figure is not necessary, but I deem it the best. It is made of sheet metal, with water-legs *a*¹ surrounding the fire-chamber, and a fire-door, *b*, of ordinary form. Into the crown-sheet of the fire-chamber I firmly affix a series of tubes, *c*, that open into the fire-chamber, as smoke-flues. The upper ends of these tubes *c* are screwed or otherwise fastened into the bottom plate of a flat chamber, *d*, which I prefer to make of cast metal, as clearly shown in the sectional figures. To the upper plate of the chamber *d* a smoke-pipe, *e*, is affixed that opens into it, as seen in Fig. 2. This smoke-pipe runs up through the upper head of the shell *a* through a stuffing-box, *a*².

By this arrangement and construction of

parts the chamber *d* is allowed to yield freely to the expansions and contractions of the tubes *c* before named, the pipe *e* sliding through the stuffing-box *a*² for that purpose. I connect the side shell *a* with the head by means of angle-iron *f* riveted to the shell to which the head is bolted, as shown in Fig. 2. To insure the perfect combustion of the fuel I introduce an air-pipe, *h*, that extends up through the bottom of water-leg *a*¹ parallel with tubes *c*, and opens into the chamber *d*, supplying air at that point to consume the unburned fuel escaping into said chamber.

The water-injection pipe *i*, after entering the boiler, is turned upward, extending some distance above the entering-orifice, so as to heat up the water somewhat before entering the generator from said pipe, which I deem important in point of economy in the use of said generator.

Having thus fully described my improved steam-generator, I claim—

1. The combination of the tubes *c*, movable chamber *d*, and sliding smoke-pipe *e*, passing through a stuffing-box in the top of the boiler, constructed and arranged substantially as and for the purposes set forth.

2. The combination of the straight air-tube *h* with the movable adjustable chamber *d*, as described, and passing down through the water-leg within the boiler, so as to accommodate it to the expansion and contraction of the tubes *c*, as specified.

ROYAL H. THOM.

Witnesses:

J. J. GREENOUGH,
PETER B. MCLENNAN.