

W. H. BURGESS.
Cotton and Hay Press.

No. 167,741.

Patented Sept. 14, 1875.

Fig. 1.

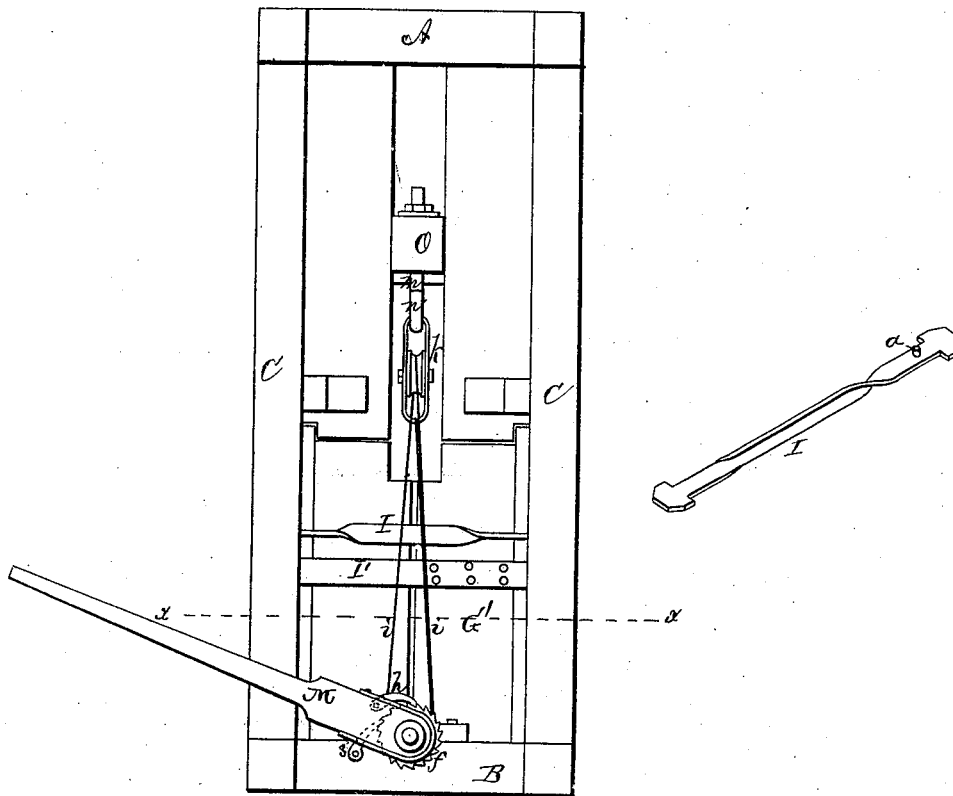
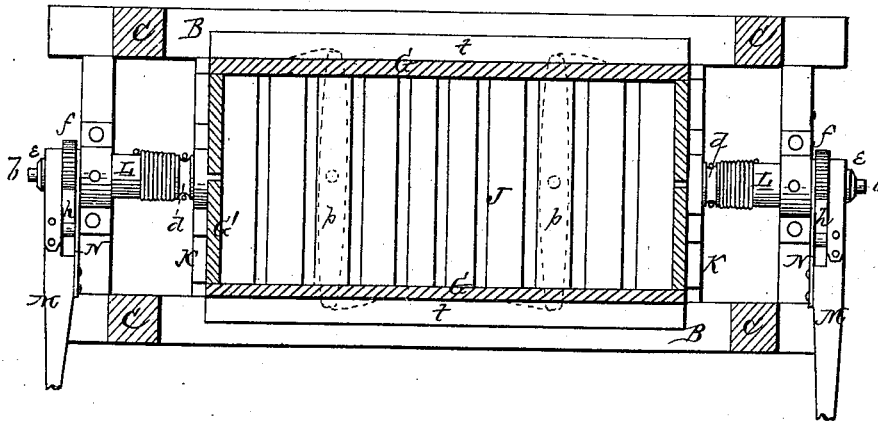

Fig. 2.



WITNESSES

Henry N. Miller
Q. L. Everitt

By

INVENTOR

Wm. H. Burgess.
Alexander Sheldon
Attorney

W. H. BURGESS.
Cotton and Hay Press.

No. 167,741.

Patented Sept. 14, 1875.

Fig. 3.

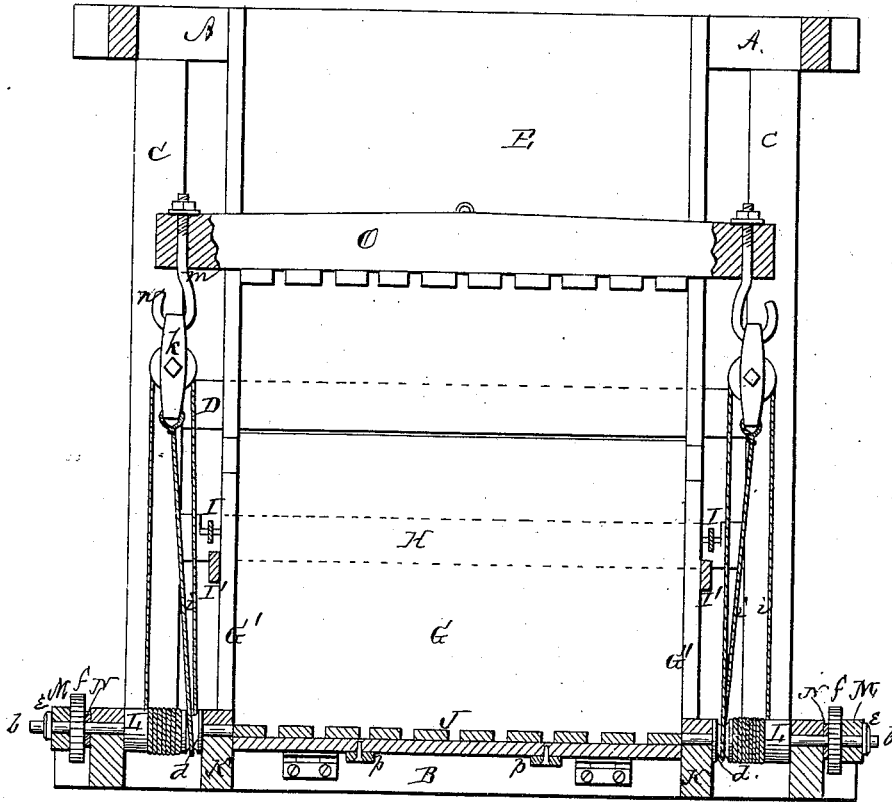
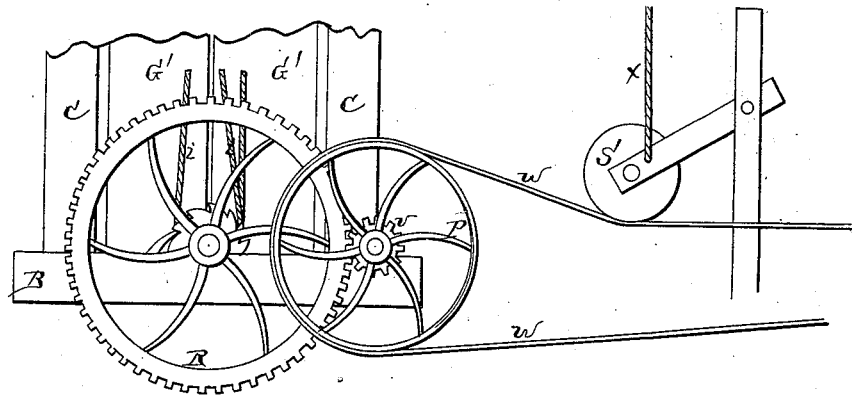

Fig. 4.



WITNESSES

Henry N. Miller
C. L. Everb.

By

INVENTOR

W. H. Burgess.
Alexander Watson
Attorney

UNITED STATES PATENT OFFICE.

WILLIAM H. BURGESS, OF JACKSON, NORTH CAROLINA.

IMPROVEMENT IN COTTON AND HAY PRESSES.

Specification forming part of Letters Patent No. 167,741, dated September 14, 1875; application filed May 6, 1875.

To all whom it may concern:

Be it known that I, WILLIAM H. BURGESS, of Jackson, in the county of Northampton and in the State of North Carolina, have invented certain new and useful Improvements in Cotton and Hay Presses; and do hereby declare that the following is a full, clear, and exact description thereof, reference being had to the accompanying drawings, and to the letters of reference marked thereon, making a part of this specification.

The nature of my invention consists in certain improvements upon the cotton-press for which Letters Patent No. 149,988 were granted to me April 21, 1874, as will be hereinafter more fully set forth.

In order to enable others skilled in the art to which my invention appertains to make and use the same, I will now proceed to describe its construction and operation, referring to the annexed drawings, in which—

Figure 1 is an end elevation of my improved cotton-press. Fig. 2 is a horizontal section of the same through the line *x x*, Fig. 1. Fig. 3 is a longitudinal vertical section of the press; and Fig. 4 is an end elevation, showing the mode of applying power to the press.

The frame-work of my press is composed of a top frame, A, bottom frame B, and vertical corner-posts C C connecting the same, and the two posts on front and rear sides of the press connected by a horizontal bar, D; at or near the center. E is the bale-box, permanently attached to the top frame A and side bars D D. Below these bars the box forms side doors G G and end doors G' G', as described in my former patent above referred to. Each side door G is provided on its outer side with a horizontal bar, H, notched at its ends, and the side doors are held together by means of iron bars I I passing along the outside of the end doors G'. The bars I have T-heads at their ends, and a suitable distance inward from one end each bar is provided with a pin, *a*, to act precisely in the same manner as described in my former patent. The end doors G' are made each in two parts. In the bottom frame B of the press is a cross-bar, K, at each end of and close up to the platform or bottom J of the bale-box. On each end bar of the frame B and its adjoining cross-bar K are secured suitable jour-

nal-boxes, in which is placed a shaft, *b*, on a line with the longitudinal center line of the bottom of the press. On the inner end of the shaft *b* is loosely placed a pulley, *d*, and between said pulley and the end bar of the frame B is a drum, L, secured on the shaft. On the outer end of the shaft *b* is secured a ratchet-wheel, *f*, and outside of this ratchet-wheel is placed a loose lever, M, held from slipping off the shaft by means of a nut, *e*, screwed thereon. The lever M is notched to work over the ratchet-wheel *f*, and has a bar, N, bolted to its inner side, which is placed loosely on the shaft *b* on the inner side of the ratchet-wheel for the purpose of making the lever operate straight downward, and to avoid side or twisting pressure, and particularly to give it greater strength. The pawl *h* is hung in the space between the lever M and bar N. The drum or windlass L is, by a rope or chain, *i*, connected with a pulley-block, *k*, suspended from the projecting end of the follower-beam O, said rope or chain passing around the pulley in the block and around the pulley *d*, as shown in Fig. 3. By the arrangement of the lower pulley *d* on the same axle with the drum or windlass L and the windlass lengthwise with the press and parallel with the follower, the rope is allowed to play from one end of the drum to the other, and will yet direct the pressure directly downward, avoiding all side draft. The pulley-block *k* is attached to the follower-beam O by means of a rod, *m*, having an eye or hook, *n*, at its lower end, on which the pulley-block is suspended, in order the more easily to detach the pulley-block from the follower, and for the purpose of allowing the pulley-block to hang perpendicularly, no matter how the follower may incline. One section of each end door G' is provided with a cross-bar, I', fastened thereto, and arranged to fit in notches or slides in the bars H of the side doors G, for the purpose of more firmly supporting the box. The pressing-platform or bottom J of the bale-box is hinged at one side in such a manner as to open upward, (the press being inverted,) and secured in place by pivoted bars *p p*, in order to admit the cotton if the press should be required to work upward, as would most likely be the case in the application of power to the press. To make

the press work upward it is only necessary to put the stop *s* on the opposite side of the ratchet-wheel, and use the lever on the side the stop was taken from, and placing the fastening-bars *t* on the cross-beams *D D*, so as to secure the doors, which are to be used the same end up in the press, pressing upward or downward.

In Fig. 4 I have represented the method of applying power to the press. The power is applied to a band-wheel, *P*, on the axle of which is a pinion, *v*, engaging with a cog-wheel, *R*, placed upon the shaft or axle *b*, which, in this case, should extend the entire length of the press, and have both windlasses thereon. The axle in this case passes below the pressing-bed, or, rather, in a groove in the pressing-bed, (allowing the same to open and shut,) and a little to one side of the center of the frame, in order that the ropes shall pull directly downward or upward, as the case may be. To operate by power the band *w* is adjusted on the driving-wheel and the wheel *P* of the press. Then the spool *S* is lowered to rest on and tighten the band *w* sufficiently to communicate the force necessary to the wheel *P*, which revolves the pinion *v*, engaging with the wheel *R*, which turns the windlasses situated at either end of the press on its axle. When the cotton is sufficiently compressed the spool *S* is raised by means of the cord *x*

or otherwise, which stops the motion, and the ratchet-wheel holds the follower until the bale is tied in the usual manner. When the bale is secured the stop *s* is raised, and the follower—in the press working upward—descends from the force of gravity to admit the cotton for another bale.

This arrangement is very strong and durable, simple and effective in operation, and requires the power and time of the engine only in compressing. When the pressure is released the follower adjusts itself.

Having thus fully described my invention, what I claim as new, and desire to secure by Letters Patent, is—

1. The headed bars *I I'*, provided with the pins *a a*, in combination with the doors *G G'* and notched bars *H H*, as and for the purposes set forth.

2. The combination of the windlasses *L L*, arranged lengthwise of the press, and provided with pulleys *d d*, the notched levers *M M*, with bars *N N*, ratchet-wheels *f f*, and pawls *h h*, all constructed substantially as set forth.

In testimony that I claim the foregoing I have hereunto set my hand this 20th day of April, 1875.

W. H. BURGESS.

Witnesses:

AUGUSTUS MCDANIL,
WILLIAM J. BROWN.