

J. K. CALDWELL.

Pulverizing-Machine for Clay and Similar Substances.

No. 167,742.

Patented Sept. 14, 1875.

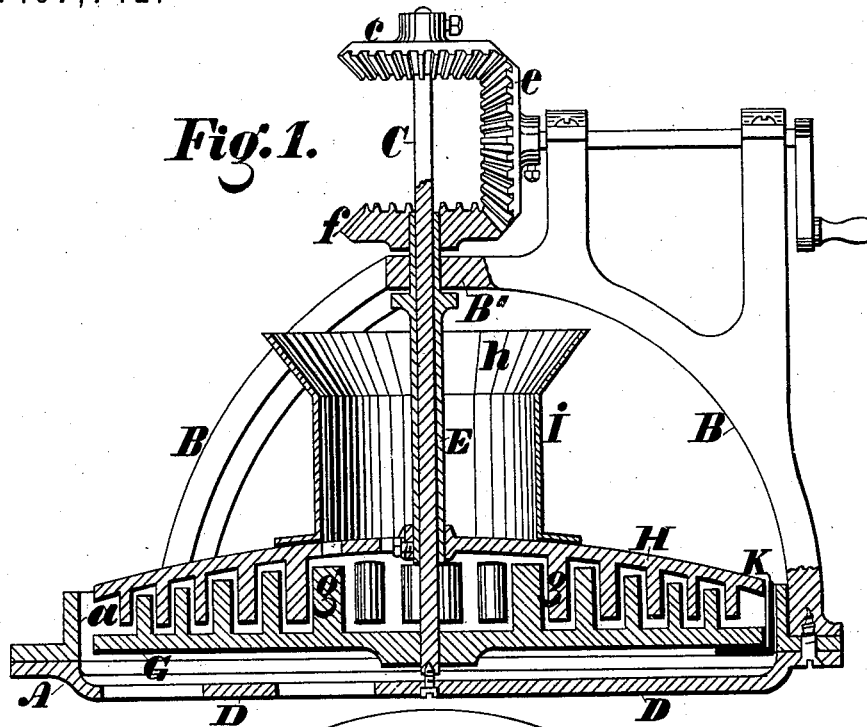
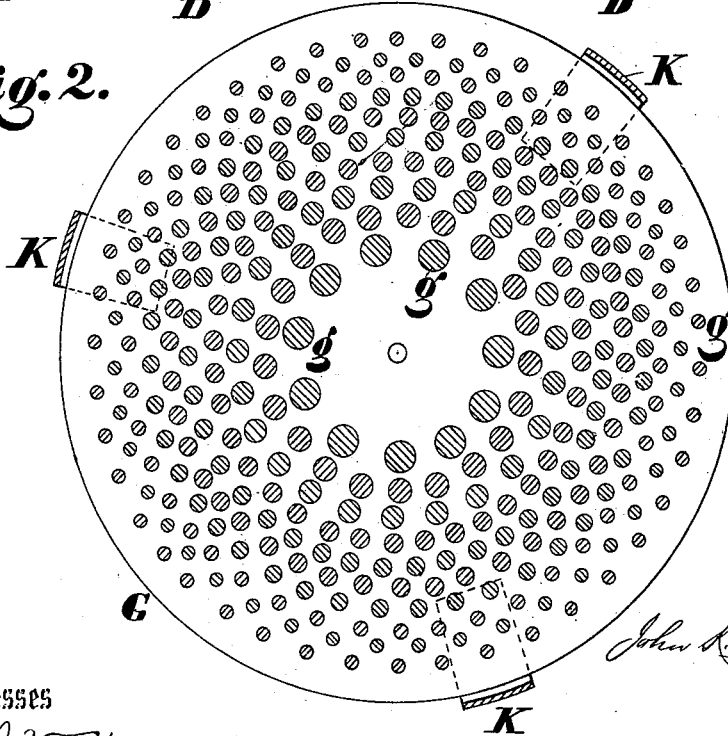

Fig. 2.



Witnesses

Saml. J. VanStavoren

J. P. Connolly

By

Connolly Bros., Attorneys

John K. Caldwell
Inventor,

UNITED STATES PATENT OFFICE

JOHN K. CALDWELL, OF PHILADELPHIA, PENNSYLVANIA.

IMPROVEMENT IN PULVERIZING-MACHINES FOR CLAY AND SIMILAR SUBSTANCES.

Specification forming part of Letters Patent No. 167,742, dated September 14, 1875; application filed August 19, 1875.

To all whom it may concern:

Be it known that I, JOHN K. CALDWELL, of Philadelphia, in the county of Philadelphia and State of Pennsylvania, have invented certain new and useful Improvements in Pulverizing-Machines; and I do hereby declare the following to be a full, clear, and exact description of the invention, such as will enable others skilled in the art to which it pertains to make and use it, reference being had to the accompanying drawings, which form part of this specification, in which—

Figure 1 is a transverse vertical section. Fig. 2 is a horizontal section on a line between the plates G and H.

My improvements consist in the peculiar construction and combination of parts, as hereinafter fully described.

Referring to the accompanying drawing, A designates the base of the machine, on which are supported arched standards B B B, which intersect at B', forming a bearing for a shaft, C, whose lower end fits in bearings in the arms D D D. E is a hollow shaft, surrounding the shaft C, both said shafts being revolved in contrary directions by the beveled gear *c e f*. G is a flat disk, firmly affixed to and moving with the shaft C; and H is a concave disk, secured in like manner to the shaft E. I is a hopper, secured to the disk H, and surrounding the opening *h* in the latter. K shows a scraper, of which there may be one or more affixed to the disk G, and designed to remove from the face *a* of the base A any pulverized material that may be deposited thereon. Upon each of the disks G and H are arranged annular rows of studs or pendants *g g*, alternating, as shown, so as to revolve in different circles.

The disk G, which is shown flat, may be made convex, having, however, a curvature different from that of the disk H, so as to decrease the distance between said disks to decrease from the center to the circumference. If desired, the shaft E may be furnished with radial arms to operate in the hopper I.

The advantage of the foregoing construction

is, that as the centrifugal force generated will impel the substances (clay or other material) fed into the hopper from the center to the circumference of the disks, or cause such substance to be forced between two converging disks, the pulverizing operation will be most perfectly accomplished. In other words, the centrifugal force being greater at the circumference than at the center, while the distance between the disks diminishes from the latter to the former, the lumps of clay fed into the hopper will be gradually broken and comminuted by the studs or pendants, while, at the same time, they will be forced through a gradually-decreasing passage or opening, and therein thoroughly pulverized before being ejected from the disks.

What I claim as my invention is—

1. In a centrifugal pulverizing-machine, the combination of the flat or convex disk G, and the concave disk H, said disks being armed with studs or pendants, revolving in opposite directions, and relatively so arranged that the distance between them diminishes from center to circumference, substantially as shown and described.

2. In a centrifugal pulverizing-machine, the combination of two studded disks revolving in opposite directions in horizontal planes, the studs *g g* projecting from the faces of the disks, substantially as shown and described.

3. The combination of the base A, standards B B B, shafts C E, gear-wheels *c e f*, and disks G H, combined for operation substantially as shown and described.

4. In combination with the base A, the scraper K, attached to the disk G and revolving therewith, substantially as shown and described.

In testimony that I claim the foregoing I have hereunto set my hand this 12th day of August, 1875.

JOHN K. CALDWELL.

Witnesses:

GEO. C. SHELMEKDINE,
M. DANL. CONNOLLY.