

W. H. DOANE & G. W. PASSEL.
Planing-Machine.

No. 167,749.

Patented Sept. 14, 1875.

Fig. 1.

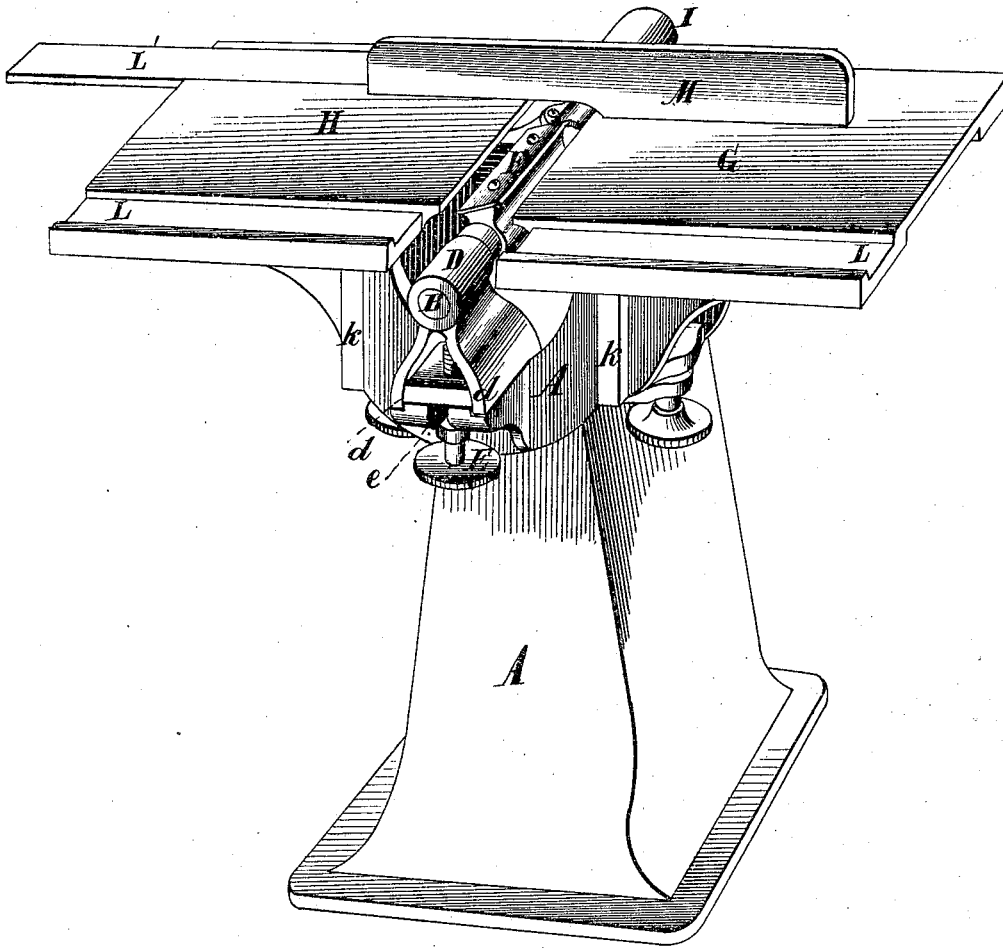
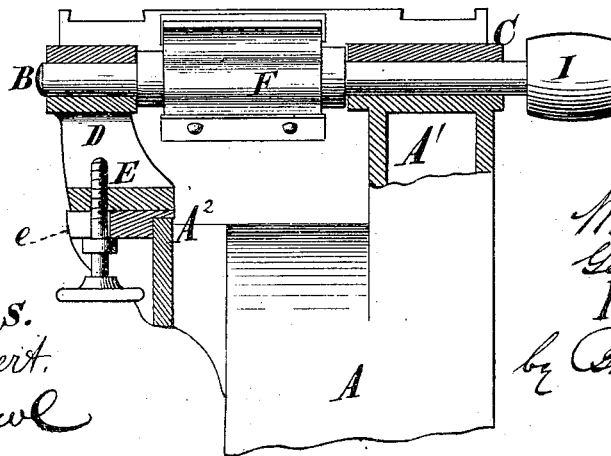

Fig. 2.



Witnesses.
A. Ruppert.
D. P. Cowl

W. H. Doane
Geo. W. Passel
 Inventors
 by *A. Edw. Cils*
their Atty

W. H. DOANE & G. W. PASSEL.
Planing-Machine.

No. 167,749.

Patented Sept. 14, 1875.

Fig. 3.

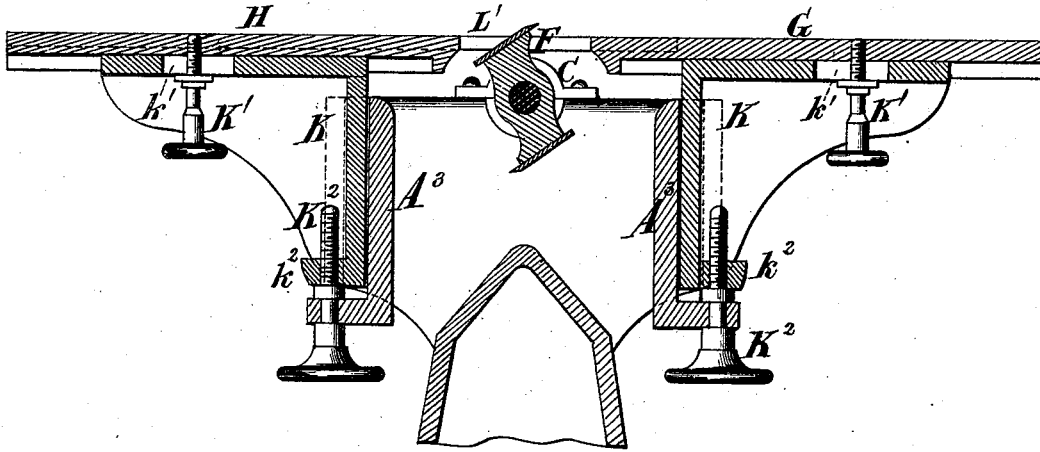

Fig. 4.

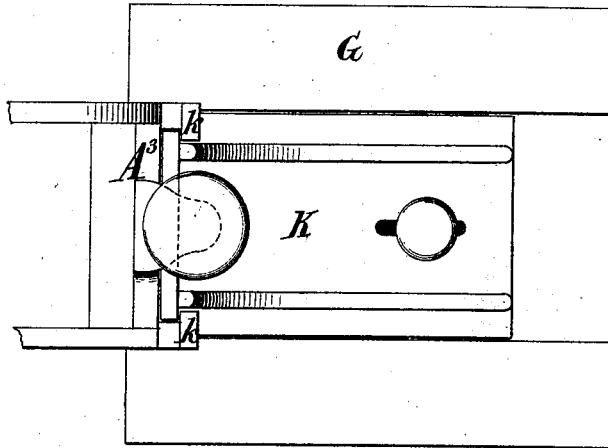
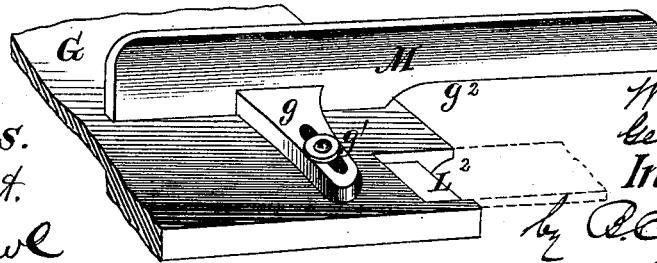

Fig. 5.



Witnesses.
A. Ruppert.
D. P. Cowl

W. H. Doane
Geo. W. Passel
Inventors
by P. B. J. C. S.
their Atty

UNITED STATES PATENT OFFICE.

WILLIAM H. DOANE AND GEORGE W. PASSEL, OF CINCINNATI, OHIO,
ASSIGNORS TO J. A. FAY & CO., OF SAME PLACE.

IMPROVEMENT IN PLANING-MACHINES.

Specification forming part of Letters Patent No. **167,749**, dated September 14, 1875; application filed
April 24, 1875.

To all whom it may concern:

Be it known that we, WILLIAM H. DOANE and GEORGE W. PASSEL, both of Cincinnati, in the county of Hamilton and State of Ohio, have invented certain new and useful Improvements in Planing-Machines, of which the following is a specification:

This invention relates to that class of hand-planing machines, so termed, although they are also used for grooving and gaining, in which the cutter-head operates between two separate tables, adjustable both vertically and horizontally independently of each other, so that they may be arranged either in the same plane or in different planes, according as the nature of the work to be done may require, while they may also be separated to a greater or less extent, to adapt the gap between them to cutter-heads of various diameters.

Our improvement consists, first, in providing one of the two tables with a slide, to be used in gaining or grooving for bridging the gap between the tables at one end of the cutter-head, so that the stick of timber may have a support at this end of the cutter-head as well as at the other end, where it is held in the gainer-frame.

Heretofore a third table has always been provided for this purpose in this class of machines, which not only makes them cumbersome, but also requires additional mechanism for affording the means of adjusting this third table. All this is avoided by the use of this simple slide.

Second, in novel means for supporting and rendering adjustable the tables, which will be clearly explained in the ensuing description.

In the annexed drawings, Figure 1 is a perspective view of our improved machine. Fig. 2 is a transverse section thereof. Fig. 3 is a longitudinal section of the same. Fig. 4 is a bottom view of one of the tables, together with its supporting bracket and the guides for the latter. Fig. 5 is a perspective view, illustrating more particularly the fence and the manner of connecting it to the front table.

The same letters of reference are used in all the figures in the designation of identical parts.

A refers to the column or stand of the machine, on the upper end of which suitable webs are formed to afford means for supporting the tables and cutter-spindle in a position properly elevated above the central column. The spindle B, arranged horizontally across the machine, is, at one end, supported in a bearing, C, fixed or cast on the top of web A', and at the other end in a removable bearing-block, D, the base of which, about on a line with the top of column A, has a couple of longitudinally-disposed ribs, *d*, fitting corresponding grooves in the bracket A², cast upon or secured to the column A. The bearing-block is secured to the bracket by a clamping-screw, E, which passes through a slot in the outer edge of the bracket into a tap in the base of the bearing-block, so that to remove the latter requires only a few turns of the screw to loosen its hold on the bracket.

The seat of the bearing-block D is parallel to the axis of the cutter-spindle, so that it may be readily removed from and again slipped on the outer end of such spindle when it becomes necessary to substitute one cutter-head for another.

The cutter-head F is arranged between the tables G and H upon the spindle B, which is driven by a pulley, I, to impart the required rotary motion to the cutter-head, which is so secured on its spindle that it may be readily removed therefrom. Each table is supported upon a bracket, K, which is arranged in guides *k* on the transverse web A³ of the stand or column A. The horizontal leaf of the brackets K fits a recess in the under side of the table it carries, and they are secured together by a set-screw, K¹, which passes through a longitudinal slot, *k*¹, in the bracket into a nut or tap in the table. The tables may thus be adjusted horizontally to and from the cutter-head, so that their inner ends can always be arranged close to the path of the cutters. The brackets K are maintained at any required elevation in their guides by screws K², which are supported in lugs on the webs A³, and work in nuts *k*² fixed on the brackets. Of course each table may be adjusted independently of the other. In planing stuff the surface of the rear table H will be arranged in

the same plane in which the highest point that the bits reach is located, and the front table G will be adjusted such a distance below this plane that the cutters will remove the desired thickness of shaving from the stuff, which is thus firmly supported, both in front and rear of the cutters, upon the two tables, being pushed from the lower onto the higher one as the planing proceeds.

In grooving and gaining the tables will be disposed in the same horizontal plane, and the slide of the gainer-frame will traverse back and forth in the ways L, provided as usual in the tables past the outer end of the cutter-head.

To afford a continuous surface at the other end of the cutter-head, as is required in grooving and gaining, we provide table H with a slide, L¹, flush with the surface thereof, which, at such times, is to be slid into the recess L² in table G, thus bridging the gap between the tables, and doing away with the necessity of a third table. The fence or guide M is connected to the front table G, having a slotted laterally-projecting arm, g, which affords the means for securing it to the table by means of a bolt or screw, g¹. It reaches beyond the gap, and overhangs the rear table, its lower edge being cut away, as at g², so that the rear

table can be properly elevated above the front table without interfering with the guide or fence attached thereto.

The fence can be readily adjusted, and may be easily removed when the machine is to be used for gaining stuff.

We do not here claim the use of the axially-removable bearing-block D, as we intend to cover this feature in a separate patent.

What we claim as our invention, and desire to secure by Letters Patent, is—

1. The combination of table H, slide L¹ fitted in a longitudinal groove therein, and table G, having a recess, L², in the end adjacent to table H, substantially as and for the purpose specified.

2. The combination of table G or H, slotted bracket K k¹, guides k k, screw K¹, nut k², and screw K², substantially as and for the purposes specified.

In testimony whereof we have signed our names to the foregoing specification in the presence of two subscribing witnesses.

W. H. DOANE.
GEO. W. PASSEL.

Witnesses:

B. STOREE, Jr.,
I. J. MILLER.