

A. W. ELDREDGE.
Oscillating Balanced Valve.

No. 167,754.

Patented Sept. 14, 1875.

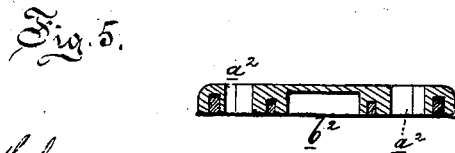
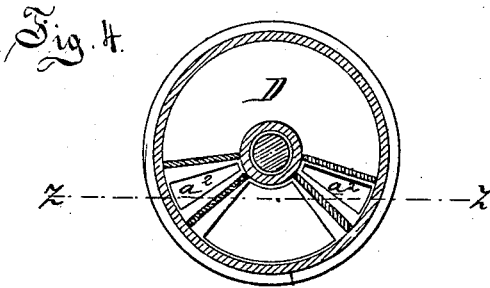
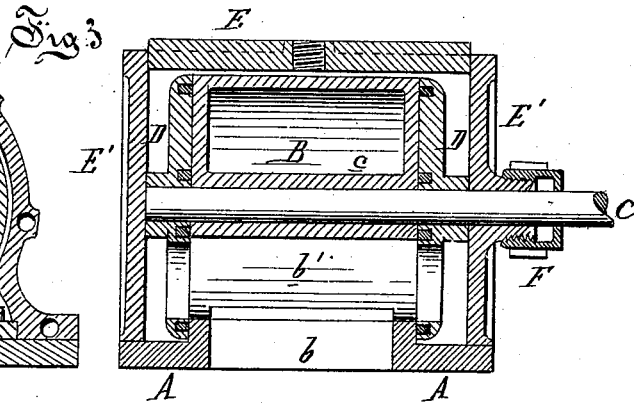
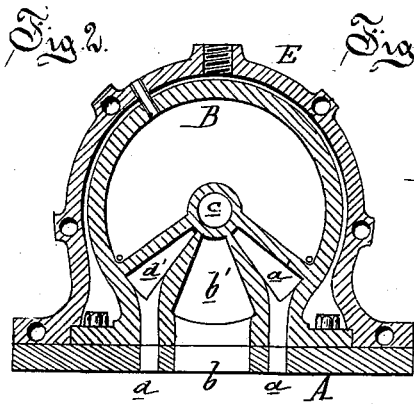
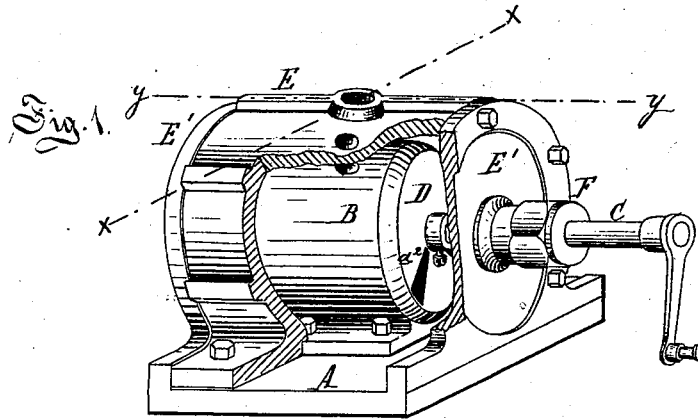

Attest:
Edward Barthel
W. P. Spalding

Inventor:
A. W. Eldredge
By Atty
Wm. S. Sprague

UNITED STATES PATENT OFFICE.

ALONZO W. ELDREDGE, OF BIG RAPIDS, ASSIGNOR OF ONE-FOURTH HIS
RIGHT TO FITCH PHELPS, OF MECOSTA, MICHIGAN.

IMPROVEMENT IN OSCILLATING BALANCED VALVES.

Specification forming part of Letters Patent No. 167,754, dated September 14, 1875; application filed
June 17, 1875.

To all whom it may concern:

Be it known that I, ALONZO W. ELDREDGE, of Big Rapids, in the county of Mecosta and State of Michigan, have invented an Improvement in Steam-Engines, of which the following is a specification:

The nature of my invention relates to an improved form of balanced oscillating valves for a steam-engine; and consists in the peculiar construction of an elevated valve-seat, and the combination therewith of two circular valves, one at each side, mounted on a rock-shaft which oscillates through the axis of said seat.

Figure 1 is a perspective view, with a portion of the steam-chest broken away. Fig. 2 is a longitudinal vertical section at $x x$. Fig. 3 is a transverse vertical section at $y y$. Fig. 4 is an elevation of the face of one valve. Fig. 5 is a cross-section of the same at $z z$.

In the drawing, A represents that part of a steam-cylinder which is included in the steam-chest, having the steam-ports $a a$, with an exhaust-port, b , between them. B is a longitudinally-disposed elevated valve-seat, bolted to the ordinary valve-seat A. Two transverse ports, $a^1 a^1$, are radially cut through the raised seat, with a passage from each leading down to the port a below it. Between the ports a^1 an exhaust-port, b^1 , extends transversely through the seat, and from the interior a short passage communicates with the exhaust-port b of the cylinder.

The sides or checks of the seat B are circular, and through the axis is cored a bearing-tube, c , for the rock-shaft C. The seat, above the ports $a^1 a^1$, is cored out, forming a sector-shaped chamber.

D D are two disk-valves, each formed with a radial steam-port, a^2 , at each side of a radial exhaust-recess, b^2 , cored in its inner face, and is axially mounted on the rock-shaft C. E is the steam-chest, bolted to the cylinder, and is provided with the heads $E' E'$, one at each side, through one of which the rock-shaft oscillates in a stuffing-box, F. Near the periphery of each valve an annular groove is turned in its face, and another one close to the central eye, through which the

rock-shaft is inserted. At each side of each steam-port a radial groove is planed in the valve-face, extending from the inner to the outer groove.

In the annular grooves brass or other packing-rings c are laid in, and in the radial grooves a packing-bar, c' , is laid in each, which rings and bars may be set out, either by springs under them or by steam-pressure, as preferred, their purpose being to relieve the face of the valve from wear, and to prevent steam from blowing through from port to port.

The valves are adjustably secured on the rock-shaft by set-screws tapped through their hubs, and may be set up to the seat as occasion may require. The protruding end of the rock-shaft is fitted with an arm, C' , with which an eccentric rod may engage to oscillate the shaft and valves.

The pressure of the steam being on both valves, the seat is relieved from pressure of the valves upon the same, as the pressure of one valve is balanced by that of the other in the opposite direction through the rock-shaft.

A steam-port, a^1 , of the seat being disclosed by the port a^2 of the valve at each side, steam will flow through the passage of the port a of that end of the cylinder, while the ports a^1 of the other end of the cylinder will be closed by the valves; but the port a^1 at that end will be placed in communication with the exhaust-port by the exhaust-recess b , which is then overlapping them. When the valve is thrown in the other direction the flow of steam through the ports a is reversed, but the exhaust-port is always open to the exhaust end of the cylinder.

To lubricate the valves and the cylinder an oil-pipe, f , is tapped through the steam-chest and into the upper part or chamber of the valve-seat, in each side of which, at the lowest corner, there is tapped a very small aperture, g , which is disclosed by a valve-port for an instant at each oscillation of the valves, thereby permitting a minute quantity of oil to flow out, which is absorbed by the steam, and thus lubricates all the moving parts with which it is brought into contact.

The valves for the larger class of engines

may be cast with lugs at their peripheries, projecting beyond the edge of the chest, and stay-braces provided to connect the lugs of one valve with those of the other, to prevent the valves from springing.

What I claim as my invention is—

The valves D D, constructed as described, and mounted upon the rock-shaft C, in combi-

nation with the hollow elevated valve-seat B, provided with the ports *a' a' b'*, substantially as and for the purpose set forth.

ALONZO W. ELDREDGE.

Witnesses:

E. F. DEWEY,
F. D. BROWN.