

D. H. FOX.

Process and Apparatus for Preventing the Accumulation of Tar in Hydraulic Mains.

No. 167,755.

Patented Sept. 14, 1875.

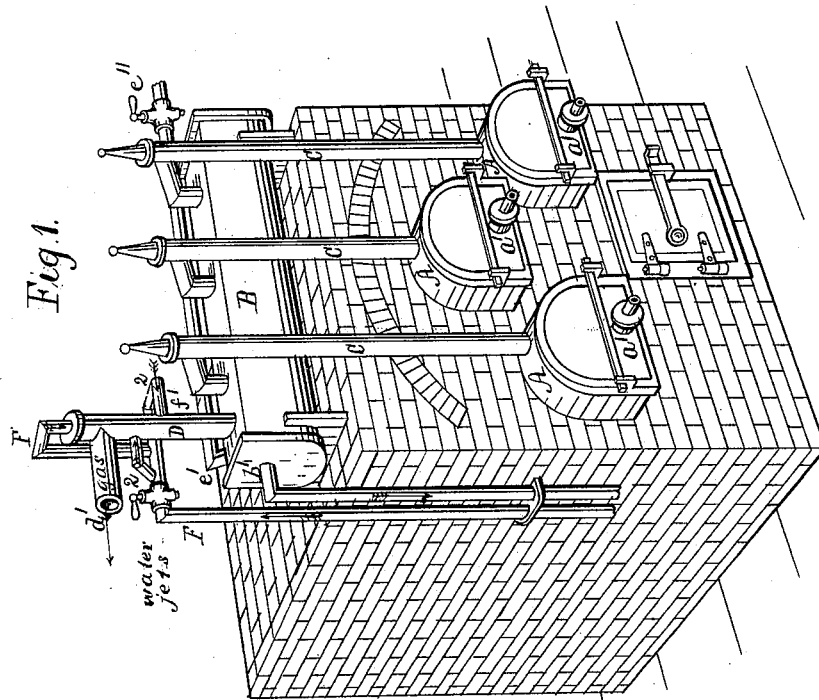
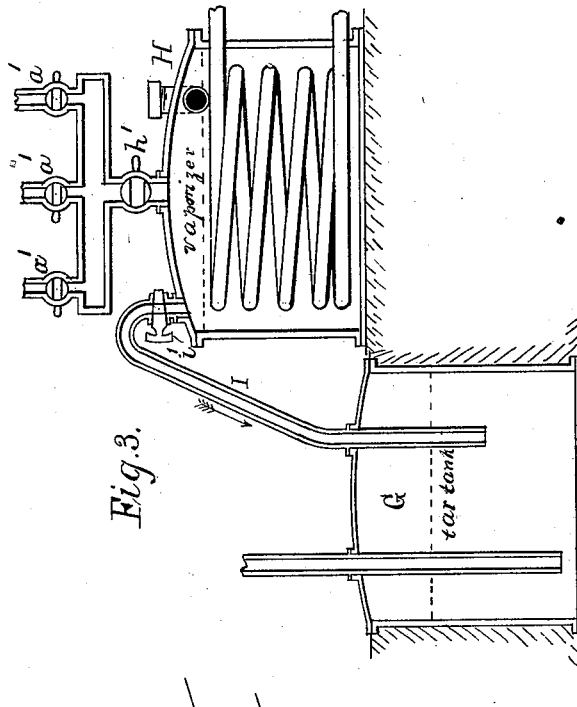
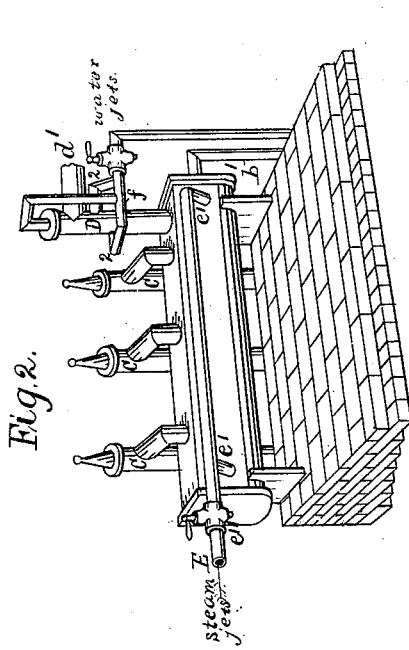

Witnesses:
Benj. Morison
Wm. H. Morison.

Inventor:
David H. Fox

UNITED STATES PATENT OFFICE

DAVID H. FOX, OF READING, PENNSYLVANIA.

IMPROVEMENT IN PROCESSES AND APPARATUS FOR PREVENTING THE ACCUMULATION OF TAR IN HYDRAULIC MAINS.

Specification forming part of Letters Patent No. **167,755**, dated September 14, 1875; application filed July 30, 1875.

To all whom it may concern:

Be it known that I, DAVID H. FOX, of Reading, in the county of Berks and State of Pennsylvania, have invented an Improved Process and Apparatus for Preventing the Accumulation of Tarry Deposits in the Hydraulic Main and Conduit-Pipes used in the Production of Illuminating-Gas, of which the following is a specification:

My improvement relates more especially to the process and apparatus for which Letters Patent, dated November 8, 1859, were granted to Leonard D. Gale, reissued March 8, 1870, and extended November 11, 1873, whereby the volatilized vapor of hydrocarbon is subjected to a sufficient heat, in retorts, to produce a fixed gas, and then drawn off from the receiving hydraulic main through a condenser by an exhauster.

In the practice of this invention I find that the excess of carbon deposited in the main and conduit-pipes is so abundant and rapid as to render it necessary to open the said main and conduit-pipes very frequently to remove the deposit, in order to prevent stoppings and possibly disastrous results.

The object of my invention is to prevent the accumulation in the hydraulic main and outlet gas-pipes of the excess of carbon, (before referred to herein,) and thus, consequently, render the practice of said Gale's invention free from the dangerous liabilities to which it is subject from said cause; and this highly important result I accomplish in a perfect and reliable manner, first, by injecting streams of steam into the carbonaceous liquid in the hydraulic main in such a manner as to keep the said liquid sufficiently agitated to effectually prevent such a thickening of the same, by the deposit of carbon, as would retard or prevent its flowing out into the usual tar-line waste-pipe which enters the ordinary underground drip-tank; second, by an arrangement of pipes injecting jet-sprays of cold water horizontally across in opposite directions into the upper portion of the take-off pipe, which leads vertically upward from the hydraulic main, and thus more effectually wash down into the said main all the free carbon that may have been carried up by the gas from the main, or liber-

ated in the take-off pipe, than can be accomplished by the vertically-dripping water heretofore used for the purpose; and, moreover, the said horizontal jet-sprays of water effectually prevent the passage of any vapor or unfixed gas from passing them, and, consequently, depositing by condensation throughout the succeeding apparatus and pipes; and the wash-water, with the free carbon, falls down into the hydraulic main and is carried off to the drip-tank; and, third, by making a direct communication between the steam-heated vaporizer and the underground tank (both of which are well known and in common use, and therefore need not be shown nor described,) by means of a gas-pipe provided with a stop-cock and leading directly from the upper part of the vaporizer directly down into the contents of the drip-tank, in such a manner that, when a sufficient quantity of gas has been made, the attendant can direct the volatilized vapor which continues to be produced in the hot vaporizer directly downward into the drip-tank, instead of directing the said vapor into the gas-pipe which passes through the condenser, as heretofore has been the practice. By this improved mode of disposing of the surplus vapor, it becomes condensed in the drip-tank, and at any time can be pumped up and used again in the vaporizer to supply the retorts; and the very objectionable deposit of free carbon in the condenser, and the possible dangerous consequences, entirely prevented; and, moreover, the usual prolonged operation of the exhauster ceases to be required.

My said process and apparatus will hereinafter be more fully and clearly described, with reference to the accompanying drawings, in which—

Figure 1 is a perspective view of a bench of retorts with the main and usual connecting-pipes, embodying my improvement in the apparatus; and, Fig. 2 a perspective view of the opposite side of the upper portion of Fig. 1; Fig. 3, a diagram explanatory of the relative positions of the drip-tank and vaporizer, and the communicating-pipe between the same.

Three retorts, A A A, are shown in Fig. 1, built in with brick-work in the usual manner, and the lids or covers provided each with a

section of the usual vapor-pipe *a'* for introducing the hydrocarbon-vapor volatilized in any suitable steam-heating volatilizing vessel or apparatus. The retorts communicate with the usual main B through the stand-pipes C O C, and the main communicates with the underground drip-tank through the drain-pipe *b'*, and with the take-off pipe D, which communicates with the pipe *d'*, that passes through the usual condenser, all substantially in the usual manner. (See Figs. 1 and 2.) For the purpose of introducing the jets of steam into the carbonaceous liquid in the hydraulic main B, I construct and secure a pipe, E, in communication with any suitable steam-generator, along beside the hydraulic main B, and by means of a plurality of lateral pipes, *e' e'*, in communication therewith and with the interior of the said main B, I inject steam into the liquid carbonaceous deposit therein in such a manner as to keep the said liquid in a sufficient state of agitation to prevent such a thickening of the same by the constant deposit of free carbon as would retard or prevent the said liquid from flowing out into the usual tar-line waste-pipe *b'*. This steam-pipe E is provided with a stop-cock, *e''*, for the purpose of regulating and stopping off the steam, as occasion may require. For the purpose of introducing the jet sprays of water horizontally across in opposite directions into the upper portion of the take-off pipe D, I construct, in connection with the usual drip-water supply-pipe F, a horizontal portion, *f'*, provided with two jet-spray pipes, 2 2, which enter, the one a little below the other, into the opposite sides of the upper portion of the take-off pipe D, so that jet sprays of the cold water will be driven horizontally across the interior of said take-off pipe D, the effect of which will be a thorough washing down of all carbon that may have risen from the hydraulic main B or been set free in the take-off pipe D, in consequence of its cooler position or the incomplete combination of the carbon with the hydrogen.

The diagram, Fig. 3, is intended to represent a vertical section of the usual underground drip-tank G, and a steam-heated vaporizer, H, in communication with each other by the pipe I, and it will be readily understood without any further description that, if

the stop-cock *i'* be opened at the time of closing the stop-cock *h'* to stop the entrance of vapor from H into the retorts, the vapor, which will continue to be produced until the said generator becomes cooled, will pass directly down into the contents of the drip-tank G, from whence it can be readily pumped up and again vaporized in the steam-heated vaporizer H and transmitted into the retorts through the conduit-pipes *a' a'*.

Having thus fully described my invention, I claim—

1. For the purpose of preventing the continuous deposits of carbonaceous matter or tar in the hydraulic main B from becoming too thick or stiff to flow freely out through the usual tar-line waste-pipe *b'*, the process of injecting live steam down into the liquid contents of said main, and thus, by the constant agitation and the consequent intimate mixing of the steam with the carbonaceous matter in the main, keeping the contents in a freely fluent condition, as hereinbefore set forth.

2. The apparatus consisting of the steam-pipe E provided with a plurality of lateral pipes, *e' e'*, opening into the interior of the hydraulic main, and receiving steam from any suitable generator, substantially as and for the purpose hereinbefore described.

3. The cold-water jet pipes 2 2, horizontally arranged to inject sprays of cold water in opposite directions into the take-off pipe D from any suitable pressure-source, substantially as and for the purpose described.

4. The pipe I, provided with the stop-cock *i'* at its upper end, in combination with the steam-heated vaporizer H, provided with a stop-cock, *h'*, near its upper end, and the sunken tank G, having the lower end of said pipe I immersed in the liquid in said tank, the said parts being constructed and arranged substantially as set forth, for the purpose of relieving the vaporizer H from the pressure of vapor by opening the stop-cock *i'* as soon as the stop-cock *h'* shall be closed, especially at the close of the day's work, as described.

DAVID H. FOX.

Witnesses:

WM. B. SCHOENER,
JOHN H. REILEY.