

A. G. COES.
Dies for Forming Wrench-Bars, &c.

No. 167,825.

Patented Sept. 21, 1875.

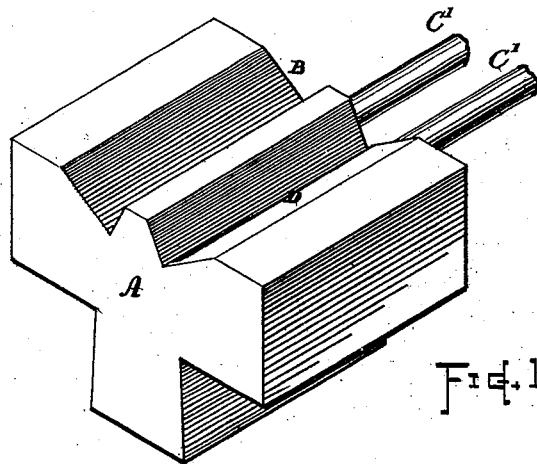

Fig. 1

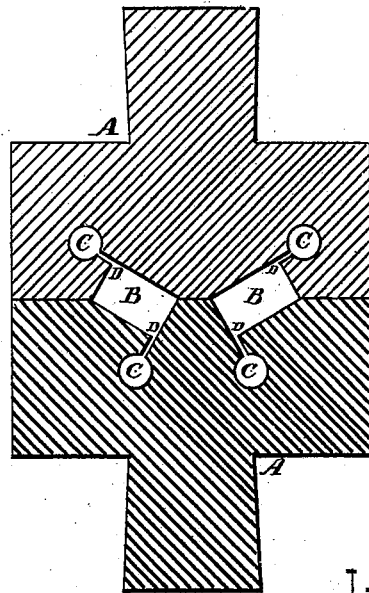

Fig. 2

Witnesses
Thomas Curleigh
Chas. B. Stilwell

Inventor
Amy G. Coes
by *Chas. B. Stilwell*
Atty.

UNITED STATES PATENT OFFICE.

AURY G. COES, OF WORCESTER, MASSACHUSETTS.

IMPROVEMENT IN DIES FOR FORMING WRENCH-BARS, &c.

Specification forming part of Letters Patent No. **167,825**, dated September 21, 1875; application filed August 11, 1875.

To all whom it may concern:

Be it known that I, AURY G. COES, of the city and county of Worcester and State of Massachusetts, have invented certain new and useful Improvements in Dies for Forming Wrench-Bars, and for similar purposes; and I do hereby declare that the following is a full, clear, and exact description of the same, reference being had to the accompanying drawings, which form a part of this specification, and in which—

Figure 1 represents a perspective view of one part of a forming-die embracing my improvement. Fig. 2 represents a transverse vertical section of the dies when closed together.

In the manufacture of wrenches, which are to be finished by grinding and polishing, it is necessary, for the production of good work, that the corners of the wrench-bars should be formed full and complete, in order that the bars, in finishing, may be ground square and with perfect angles without the waste and labor of removing much metal from their surfaces, and that all portions thereof may be properly polished, leaving no unfinished spots or scars, which the grinding and polishing wheels have failed to reach.

With the forming-dies heretofore used it has been found difficult in all cases to forge the bars full and perfect, owing to the liability of dust and scales from the iron lodging in the corners of the dies, and thereby preventing the metal from receiving a perfect impression from the die. To obviate this objection, and to provide dies which shall at all times be free from the lodging of scales is the object of my invention, which consists in combining with the matrix of the die a small inlet-passage extending longitudinally along the angle of the matrix, through which inlet I introduce a current of liquid or a blast of air, by means of which the matrix is swept clean, and the accumulation of any dust or scales is prevented.

In the drawings, A denotes the body of the dies. B indicates the matrices, in which the bars are compressed and formed, the dies A being operated by a press or drop mechanism in the ordinary manner. C C indicate inlet-passages extending into the body of the die and communicating with the interior of the matrices B by narrow longitudinal openings, D, entering along the angle in a direction parallel with, or continuous with, one of the surfaces or sides of the matrix. C' indicates pipes or tubes communicating with the passages C, and leading from a suitable reservoir or blower, which latter is not herein shown.

Water, steam, or air may be forced into the interior of the matrices through the openings D and passages C, thereby removing all scales or dust from the surfaces while the dies are in operation. The openings D in the upper and lower portions of the dies enter at different directions, one set parallel with the narrow surfaces, and the other set parallel with the broad surfaces of the matrices, so that as the bars are turned in different positions during the process of forging the several corners will be successively brought in contact with the entering current, which removes any loose scale from the bars and throws it from the matrix without permitting it to fall and lodge in the corner of the die.

Having described my improvement in dies for forming wrench-bars, what I claim therein as new and of my invention, and desire to secure by Letters Patent, is—

The improved forming-dies A, having passages C C, with longitudinal openings D at the angles of the matrices, substantially as and for the purposes set forth.

AURY G. COES.

Witnesses:

CHAS. H. BURLEIGH,
S. R. BURTON.