

J. H. BUSELL.
 Heel and Sole Trimming Machine.

No. 167,874

Patented Sept. 21, 1875.

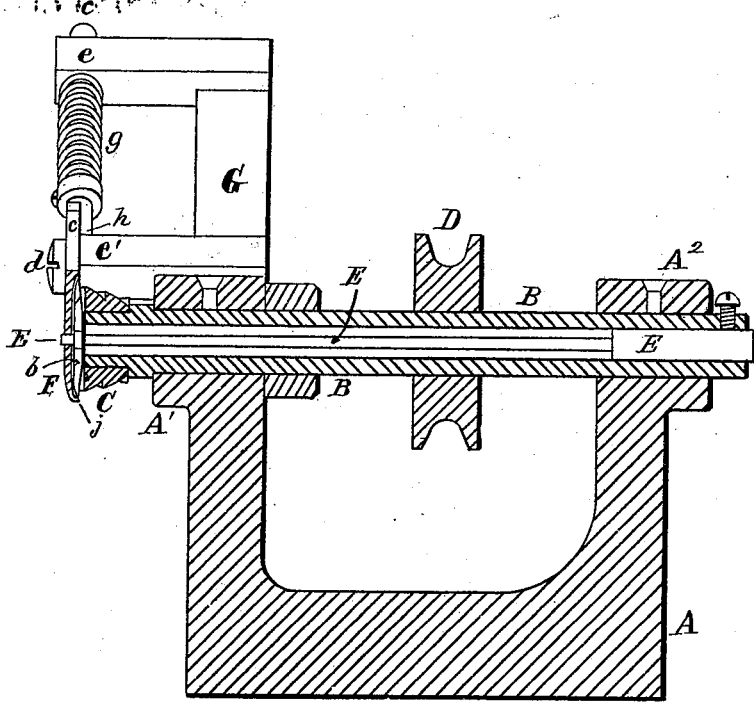

Fig. 3.

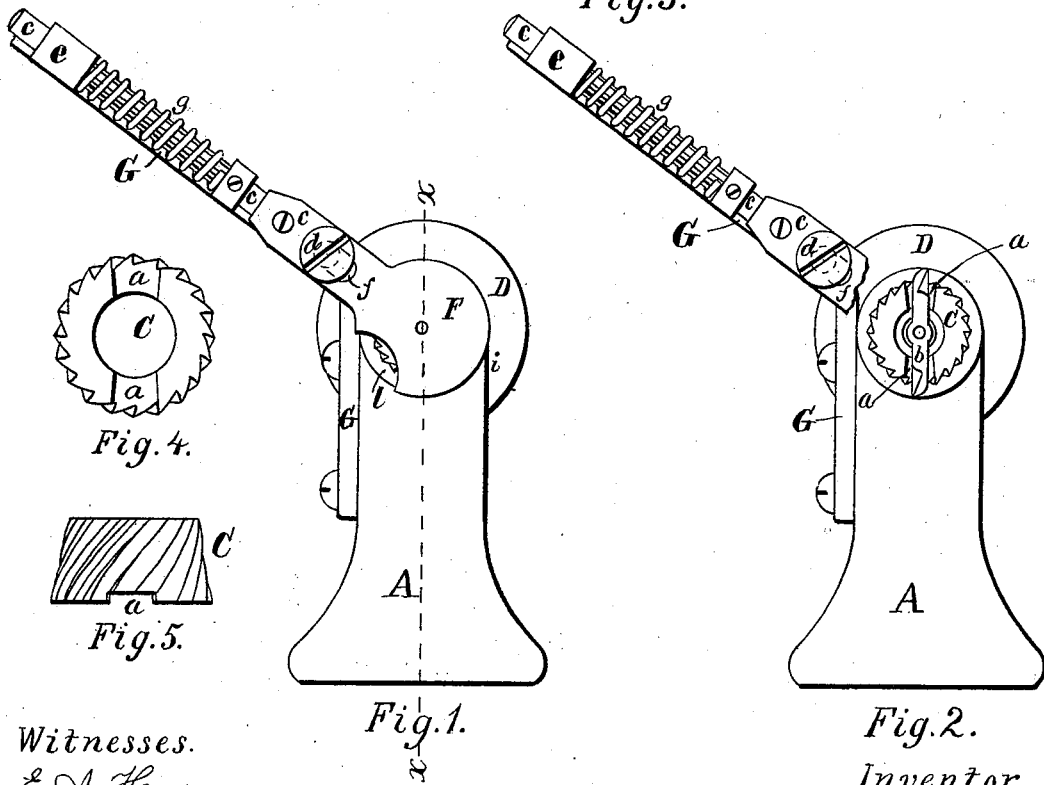

Fig. 4.

Fig. 5.

Fig. 1.

Fig. 2.

Witnesses.

E. A. Keimmenway,
 B. Andrews, Jr.

Inventor.

James H. Busell

UNITED STATES PATENT OFFICE.

JAMES H. BUSELL, OF BOSTON, MASSACHUSETTS.

IMPROVEMENT IN HEEL AND SOLE TRIMMING MACHINES.

Specification forming part of Letters Patent No. **167,874**, dated September 21, 1875; application filed July 14, 1875.

To all whom it may concern:

Be it known that I, JAMES H. BUSELL, of Boston, in the county of Suffolk and State of Massachusetts, have invented certain new and useful Improvements in Heel and Sole Trimming Machines, of which the following, taken in connection with the accompanying drawings, is a specification.

My invention relates to that class of heel and sole trimming machines in which a rotary cutter is used for reducing the edge of the heel or sole, and especially to the arrangement of the cutters and gage or guide; and it consists, first, in the use, in combination with a rotary cutter for reducing the edge of the heel or sole, of a rand-knife, arranged to revolve in unison with the edge-trimming cutter, and to be moved transversely of said cutter, or in a direction at right angles to the axis of revolution, so that its path of revolution may be either concentric or eccentric to the path of revolution of the edge-trimming cutter, for the purpose of adapting the length of that portion of the rand-cutter which projects beyond the periphery of the edge-trimming cutter upon the side next to the boot or shoe, to the depth of the rand or the projection of the sole beyond the upper.

My invention further consists in forming, in the outer radial face or end of the edge-trimming cutter, a recess or groove, in combination with a rand-knife placed within said recess or groove, and arranged to revolve in unison with said edge-trimming cutter, but in a variable path of revolution, which may be concentric or eccentric to the path of revolution of the edge-trimming cutter.

My invention further consists in mounting the edge-trimming cutter upon a hollow shaft, in combination with a small central spindle located in the hollow of said shaft, and connected therewith by means of a pin, set-screw, or other suitable device at its rear end, said spindle being made, for the greater part of its length, of considerably less diameter than the hollow in said shaft, so that its front end, upon which is secured the rand-knife, may be easily moved into a position eccentric to said hollow shaft, said spindle (which should be made of steel) springing for the purpose.

My invention further consists in the use of

a yielding rand-guide, having a recess formed in its inner face, to receive the outer end of the edge-trimming cutter, in combination with a variable rotating rand-knife, also arranged to revolve within said recess, and so connected with said yielding guide that said rand-knife will always revolve in a path concentric with said recess, in whatever position the rand-guide may be.

Figure 1 of the drawings is a front elevation of a machine illustrating my invention, Fig. 2 is a similar view with the rand-guide broken away, to show more clearly the cutting-tools. Fig. 3 is a vertical longitudinal section on line *xx* on Fig. 1. Figs. 4 and 5, are, respectively, an end elevation and plan of the edge-trimming cutter, drawn to an enlarged scale.

A is the frame of the machine, provided with the bearings A^1 and A^2 , in which is mounted the hollow shaft or sleeve B, upon one end of which is firmly secured the edge-trimming cutter C, and upon its middle the driving-pulley D. The cutter C is made from a single piece of metal, and has formed upon its periphery a series of spiral cutting-teeth, as shown, and has formed upon its outer end face the recess or groove *a*, as seen in Figs. 4 and 5. E is a steel spindle, made to fit the hollow in the sleeve B for a short distance at its rear end, its remaining portion being reduced in diameter, as shown in Fig. 3, so that its front end may be easily removed into a position eccentric to the axis of the sleeve-shaft B by springing or bending said spindle.

To the front end of the spindle E is firmly secured the rand-knife *b*, consisting of a steel bar of a width somewhat less than the recess *a* in the end face of the cutter C, and a thickness about equal to the depth of said recess, and of sufficient length to project beyond the periphery of the cutter C upon two opposite sides a distance about equal to the greatest projection of the sole beyond the upper, the projecting portion upon each end being formed of suitable shape and ground to a keen cutting-edge. F is a rand guide or shield, made nearly circular in form, with an arm, *c*, projecting therefrom, and fitted to slide endwise upon the pin *d*, and, through the bearing *e* of the stand G, secured to the frame A, in any

suitable manner. The pin *d* passes through the slot *f* formed in the arm *c*, and is screwed into the arm *e'* of the stand *G*, the end of the slot *f* serving to limit the endwise motion, in one direction, of the shield or guide *F*. The arm *c* is surrounded by the spiral spring *g*, which serves to hold the rand guide or shield *F* in a position concentric with the axis of the edge-trimming cutter *C*, in which position the shoulder *h* of the arm *c* bears against the arm *e'* of the stand *G*. The inner face of the shield *F* has formed therein a circular recess, within which the rand-knife *b* and the outer end of the cutter *C* revolve. The spindle *E* projects through the rand-knife *b*, and has a bearing in the rand guide or shield *F* concentric with the circular recess formed in its rear face. The rounded end *i* of the rand guide or shield *F* must be made thin, and the lip *j*, surrounding the recess formed in its rear face, projects over the end of the rand-knife just sufficient to prevent the upper from being injured by said cutter.

The boot or shoe to be trimmed is placed against the guide or shield *F* at *i*, and moved in a direction at right angles to the arm *c*, the guide *F* fitting into the rand of the shoe, and being made to yield by the pressure applied thereto till the cutter *C* has acted upon the edge of the sole or heel to reduce it to the proper even and true surface, while at the same time the rand-knife *b* trims the upper or rand surface of the sole in an obvious manner, the width of the cut made by said rand-knife varying according to the position of the rand guide or shield *F*.

The projection of the portion of the cutter *C* upon either side of the recess *a* serves to insure a clean cut and finish of the upper outer corner of the heel or sole.

A portion of the lip *j* surrounding the recess formed in the rear face of the guide *F* is cut away at *l*, to permit the escape of the chips taken off by the knife *b*.

What I claim as new, and desire to secure by Letters Patent of the United States, is—

1. In a heel or sole trimming machine, the combination of a rotary edge-trimming cutter and a rand-knife, arranged to rotate in unison therewith, but around an independent axis, the position of which, relative to the axis of the edge-trimming cutter, may be varied by the pressure of the boot or shoe, according as the width of the projecting portion of the heel or sole is greater or less, substantially as described.

2. The combination of the hollow or sleeve shaft *B*, cutter *C*, spindle *E*, and rand-knife *b*, all constructed and arranged to operate substantially as described, for the purpose specified.

3. The cutter *C*, provided with the recess or groove *a*, in combination with the rand-knife *b*, adapted to rotate about a movable or variable axis, as and for the purposes described.

4. In a heel or sole trimming machine, the combination of a rotary edge-trimming cutter, a rand-knife, adapted to rotate about a movable axis, and a yielding rand guide or shield, inclosing the rand-knife and forming a bearing for its spindle, substantially as described, for the purposes specified.

Executed at Boston this 12th day of July, 1875.

JAMES H. BUSELL.

Witnesses:

E. A. HEMMENWAY,
B. ANDREWS, Jr.