

C. T. LAIB.
Bedstead-Fastening.

No. 167,909.

Patented Sept. 21, 1875.

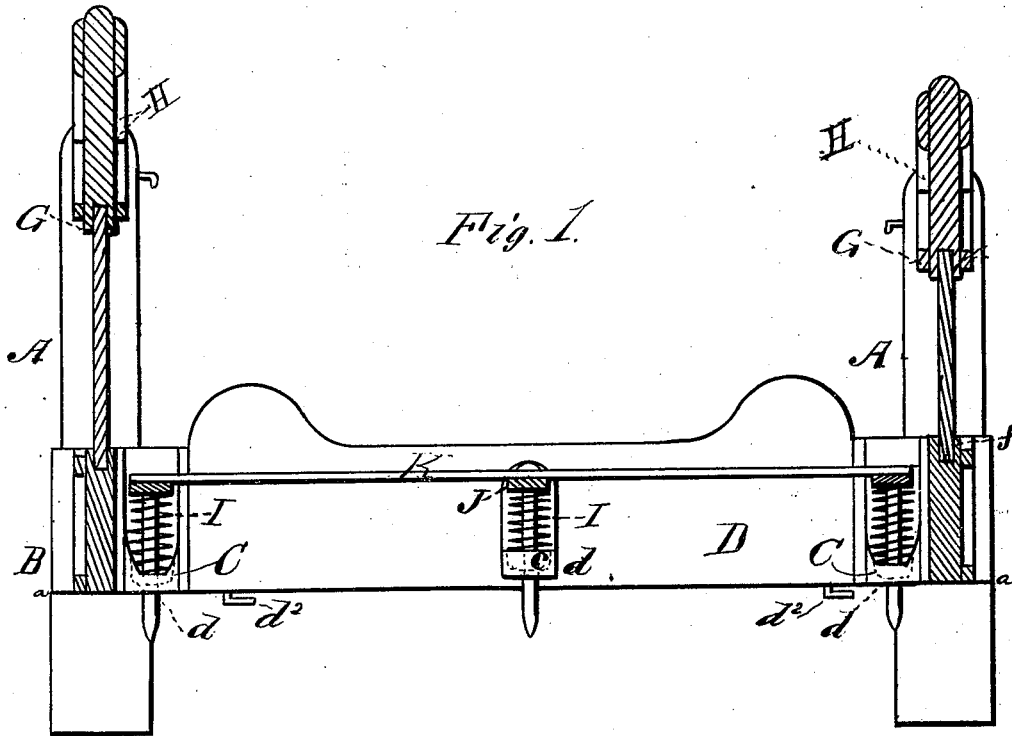

Fig. 1.

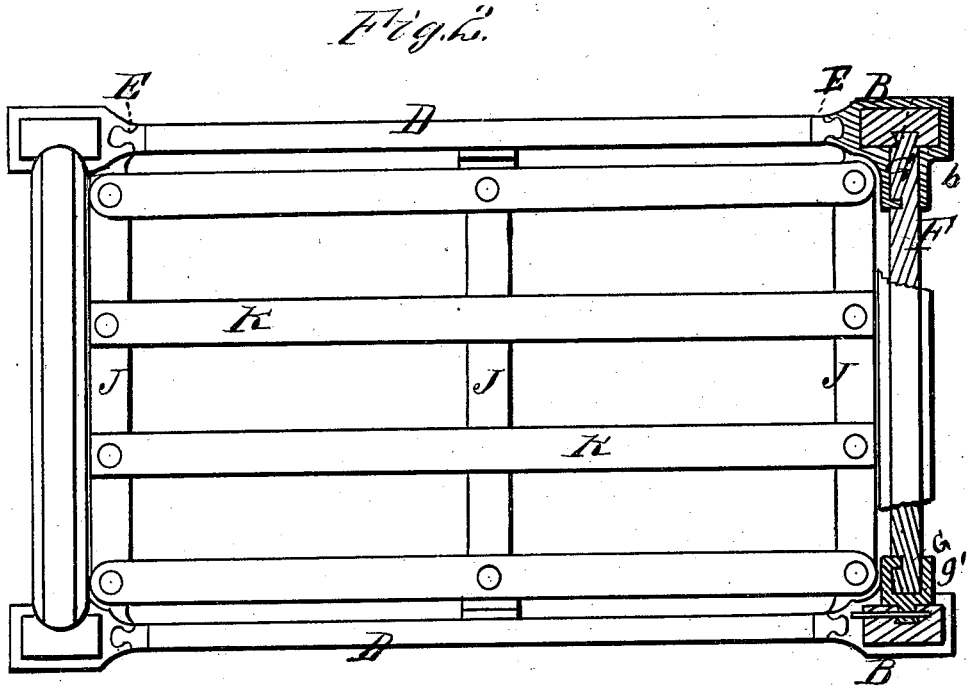

Fig. 2.

Witnesses.
Edw. J. Foley
J. S. Foley

Inventor.
Christian T. Laib
By *J. C. Lathrop*
Attorney

C. T. LAIB.
Bedstead-Fastening.

No. 167,909.

Patented Sept. 21, 1875.

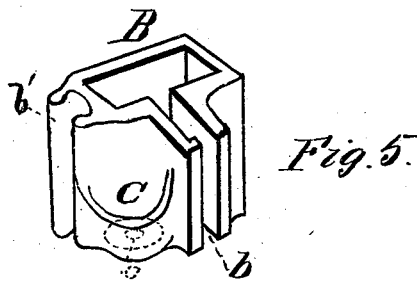
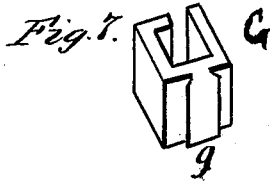
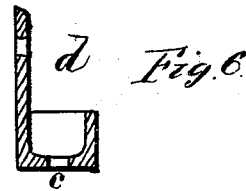
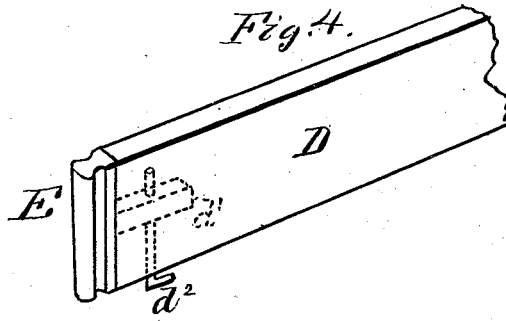
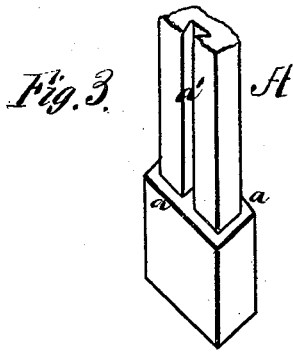

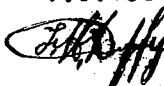
Witnesses:

 S. S. Foley

Inventor:
 Christian T. Laib
 By 
 Attorney

UNITED STATES PATENT OFFICE.

CHRISTIAN T. LAIB, OF NEW LONDON, WISCONSIN.

IMPROVEMENT IN BEDSTEAD-FASTENINGS.

Specification forming part of Letters Patent No. **167,909**, dated September 21, 1875; application filed September 16, 1874.

To all whom it may concern:

Be it known that I, CHRISTIAN T. LAIB, of New London, in the county of Waupaca and State of Wisconsin, have invented certain new and useful Improvements in Bedstead-Fastenings; and I do hereby declare that the following is a full, clear, and exact description thereof, which will enable others skilled in the art to which it pertains to make and use the same, reference being had to the accompanying drawing and to the letters of reference marked thereon, which form a part of this specification, in which—

My invention consists in a ferrule which is adapted to surround the posts, and it is provided on two of its sides with suitable slots, for the reception of the metal tenons on the ends of the side rails, and also for the ends of the end rails of the bedstead. It is further provided with bearings for a spring, preferably spiral.

This ferrule is made of metal, cast or otherwise formed, as will be more fully described hereafter.

Figure 1 is a vertical section, showing the spring-bearings and socket. Fig. 2 is a plan view, partly in section, showing ferrules and mortises. Fig. 3 is a view, showing a portion of one of the posts detached. Fig. 4 is a view, showing a portion of one of the side rails. Fig. 5 is a view, showing the ferrule detached. Fig. 6 is a view, showing a receptacle for the springs to rest upon. Fig. 7 is a view, showing a removable socket-piece.

Referring to the drawings, A A are the posts which form the four corners of the bedstead. At a suitable distance from their bottom extremities they are provided with shoulders *a a*, upon which the ferrules rest when in place, and upon one side with a longitudinal slot, *a'*, partially or wholly dovetailed, into which slots the boards of the head and foot are held in place. B B are the ferrules which slip over the small ends of the posts and rest upon the shoulders *a a*. This ferrule is provided upon one of its sides with an inclined mortise, *b*, into which the tenons on the ends of the end rails fit, and on another side with a dovetailed slot, *b'*, for the reception of the end of the side rails.

The form of these slots or mortises is not material, the necessary requisites being that

they shall form close joints with the rail-tenons.

The surface between these slots is rounded out, so as to form a receptacle for a spiral spring, and at the bottom thereof is a projection, C, which forms a suitable bearing for the spring.

A hole, *c*, in the center of this bearing-plate is provided for the pins which secure the slats, spring, and bedstead together.

D D are the side rails, of any preferred material and form, and they are provided upon their inner sides with one or more suitable bearings, *d*, for spiral springs. E is a metal tenon, provided with one or more arms, which are constructed and adapted to pass into the openings *d'*, and through these arms is a hole, through which the key-pin *d²* passes. The tenon is so formed as to correspond with the slot or dovetail groove in the ferrule B. F is the end rail, and it is provided upon its upper surface with a longitudinal groove, *f*, into which the lower board of the foot or head passes, making a close joint. Each end of this rail is so constructed that it will correspond with and fit into the longitudinal slot *a'* in the post A. G is the removable socket-piece, and it is provided with a dovetail flange, *g*, which fits into the groove *a'* in the post A, where it is secured by a key-pin, as shown. *g'* is a socket in the piece G, into which the end of the upper head and foot board passes when the same is in place. H is the upper head and foot board, and each end of the same is formed so as to correspond with the socket *g'* in the piece G.

Having thus fully described my invention, what I claim as new, and desire to secure by Letters Patent, is—

1. The ferrule B, having mortises *b b'* and spring-bearing and socket C, constructed and adapted to serve as specified.

2. The combination of the posts A A, having slots *a'* and socket-piece G, with the head and foot boards, when constructed and arranged as shown and specified.

In testimony that I claim the foregoing as my own I herewith affix my signature in presence of two witnesses.

CHRISTIAN T. LAIB.

Witnesses:

C. F. WEED,
F. C. WEED.