

W. SMITH.
Adjustable Dam.

No. 167,946.

Patented Sept. 21, 1875.

Fig 1

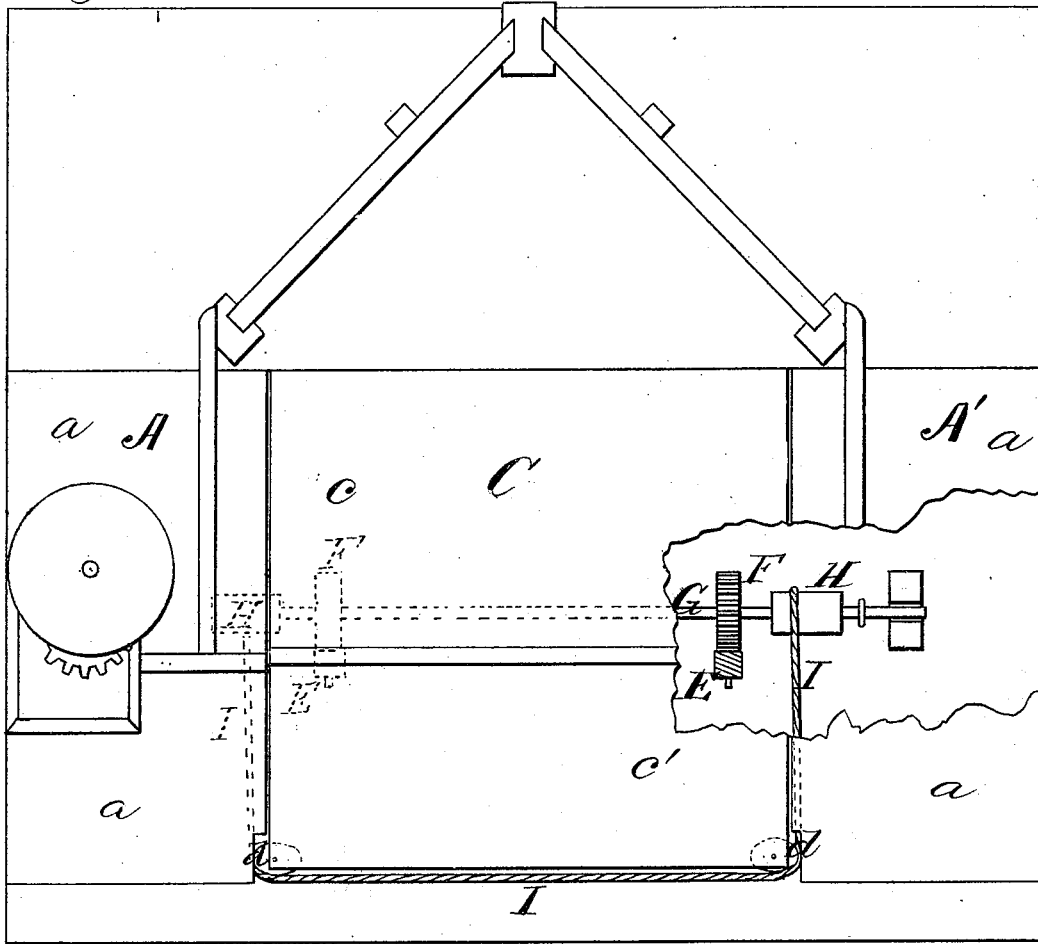
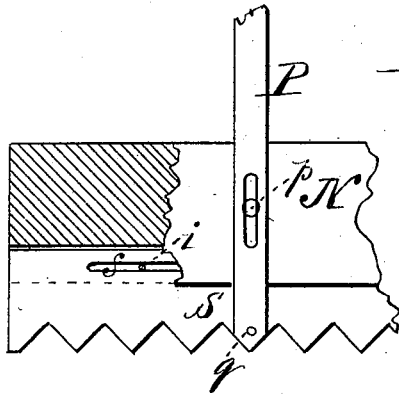

Fig 2



WITNESSES

Eugene W. Johnson
E. H. Bates

INVENTOR

Wilson Smith
Chipman & Co

ATTORNEYS

W. SMITH.
Adjustable Dam.

No. 167,946.

Patented Sept. 21, 1875.

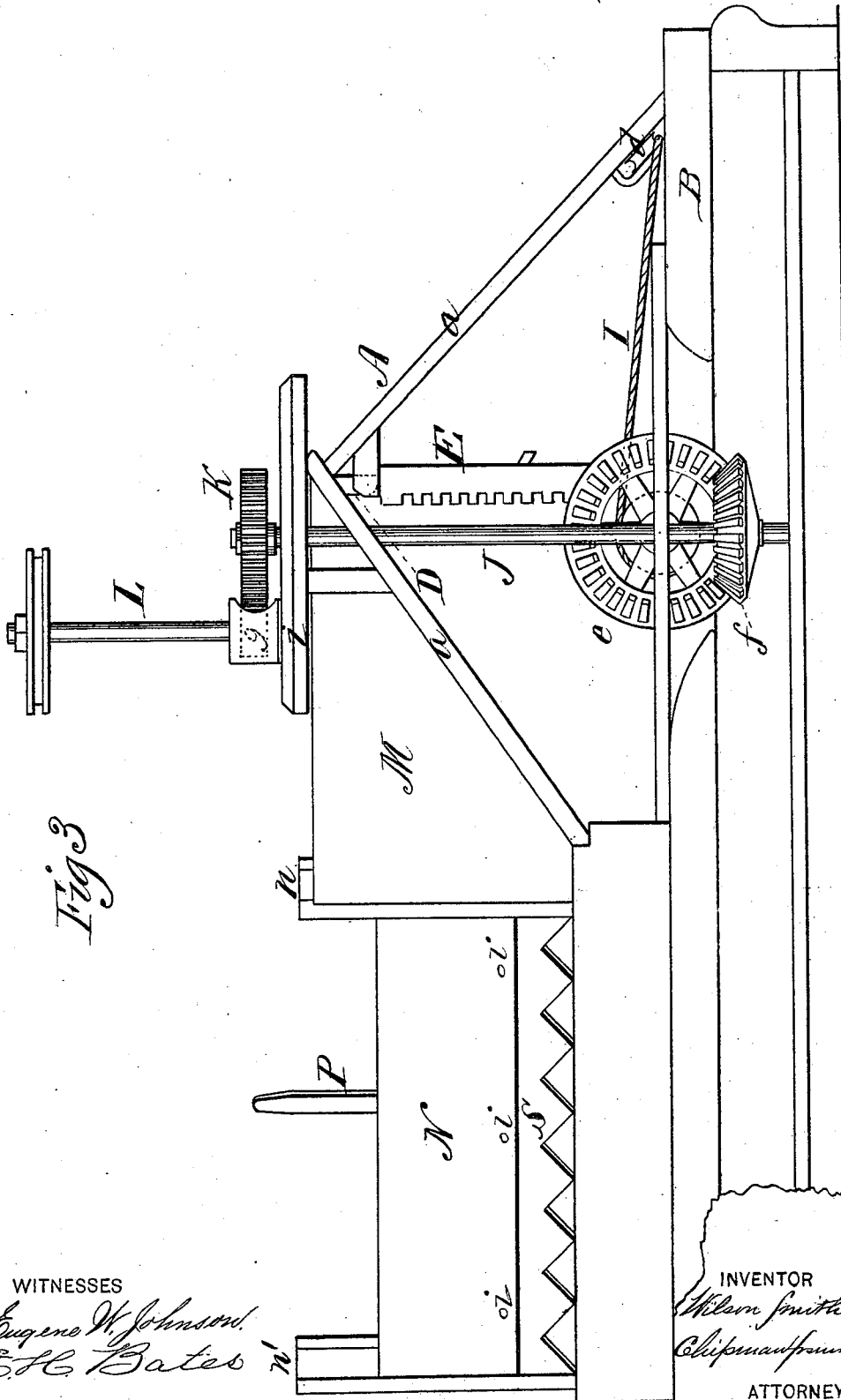

Fig 3

WITNESSES
Eugene W. Johnson
E. H. Bates

INVENTOR
William Smith
Clipsman & Co.

ATTORNEYS

UNITED STATES PATENT OFFICE.

WILSON SMITH, OF FRANKLIN, PENNSYLVANIA.

IMPROVEMENT IN ADJUSTABLE DAMS.

Specification forming part of Letters Patent No. 167,946, dated September 21, 1875; application filed July 3, 1875.

To all whom it may concern:

Be it known that I, WILSON SMITH, of Franklin, in the county of Venango and State of Pennsylvania, have invented a new and valuable Improvement in Sluices and Cofferdams; and I do hereby declare that the following is a full, clear, and exact description of the construction and operation of the same, reference being had to the annexed drawings, making a part of this specification, and to the letters and figures of reference marked thereon.

Figure 1 of the drawings is a representation of a plan view of my device. Fig. 2 is a sectional detail view of the same, and Fig. 3 is a front view thereof.

This invention has relation to improvements in devices which are designed to hold the water backed up in a stream for the purpose of obtaining a sufficient depth for floating logs, rafts, and the like down stream; and the nature of the invention consists in combining, with a vertically-adjustable sluiceway, a cofferdam made of detachable sections of boards arranged in front of the sluiceway-frame, whereby the downward flow of the water is cut off, and the bottom of the stream exposed, allowing the sluiceway and its operating mechanism to be conveniently put in position, as will be hereinafter more fully explained and claimed.

In the annexed drawings, A A' designate the end of my improved sluiceway-frame, consisting of two oppositely-inclined plane surfaces, a a', which are rigidly secured together at their points of convergence, and are arranged at a suitable distance apart upon a strong frame, B, which is designed to be anchored in the bed or channel of a running stream. This frame may extend entirely across stream, or may be located in the channel, in which latter case the said frame will have embankments extending from the stationary ends of the sluiceway to the opposite shores. The opposite ends of angular abutments A A' will be boarded up down to the bed of the river, forming a sluiceway in which is arranged a vertically-adjustable gate, C, closing the said way. This gate is composed of two sections, c c', hinged together at their upper edges, which, when thrown up, will be in the same plane with the inclined sides of abutments A

A'. By this means the flow of water down stream will be cut off until it rises above the apex of the dam thus formed. Gate C is raised or lowered in the following manner, to wit: A ridge-pole, D, of suitable strength, is arranged under the sections c c' at their point of convergence, to which is rigidly secured at each end a rack-bar, E, engaging each with a rack-wheel, F, keyed, at a suitable distance apart, upon a horizontal shaft, G, having suitable bearings in frame B. Upon this shaft are applied drums H arranged one at each side of rack-wheel F, to which drums are rigidly secured the ends of a cable or chain, I, passing over pulley-wheels d, having their bearings near the lower edge of gate-section c'. Shaft G is provided with a beveled gear-wheel, e, at one end, which engages with a second beveled gear, f, upon the lower end of a vertically arranged shaft, J, having upon its upper end a cog-wheel, K, which engages with a pinion, g, upon an actuating-shaft, L, having its bearings in a bracket, h, rigidly applied to a horizontal platform, i, on abutment A, as shown in Fig. 3. When motion is communicated to shaft G through the medium of the above-described train of gears cables I will be wound upon drums H, causing the gate C to be raised on a level with angular abutments A A', thereby closing the way, and causing the water to accumulate above it. When a sufficient quantity of water has been obtained the logs or rafts are brought near the sluiceway, and the gate lowered by reversing the motion of shaft G, when the water, which had been confined, will flow through the sluiceway, bearing the floating logs along with it into deeper water below. At the same time that the gate C was raised by the rotation of shaft G, rack-bars E will have been actuated through the medium of rack-wheels F to raise the ridge-pole *pari passu* with the elevation of the gate, thus affording the latter a support independent of the strength of the hinges connecting its sections c c', or of the rope or cable.

In order to cut off the water from the sluiceway during the location of the same and of its actuating machinery, I use the following device: Angular abutments A A' are each provided with angular side boards M, the upper edges of which are horizontal and in the same

plane with the apex of the gate and its abutments, the lower edges of which boards are buried in the bed of the river. These boards are attached to posts *n*, which are designed to be driven into the bottom of the stream, which posts, as well as a third post, *n'*, are grooved for the purpose of receiving detachable sections *N N'*, which are sustained by the said posts, and are vertically movable in reference thereto. The lower edges of these sections are deeply grooved in their length, and in these grooves are secured saw-plates *S* by means of a pin, *i*, passing through the lower edges of the said boards into a slot, *s*, in the saw-plates, which latter being somewhat shorter than the sections *N N'*, are allowed to have free endwise movement in relation thereto. The object of these saws is to cut into the bed of a river until a stratum of soil or rock shall be encountered of sufficient tenacity to resist the washing action of the current. Saws *S* are operated while their sections are in position by means of a lever, *P*, pivoted at *p* to the said sections and to the saws at *q*.

What I claim as my new, and desire to secure by Letters Patent, is—

1. The combination, with the vertically-adjustable sectional hinged gate *C*, of the supporting ridge-pole *D*, rack-bars *E*, gear-wheel *F*, shaft *G*, and its actuating machinery, substantially as specified.

2. The combination, with a dam having an adjustable sluice-gate, *C*, of the coffer-dam sections *N N'*, substantially as specified.

3. The combination, with the abutments *A A'*, of a sluiceway of the side pieces *M*, posts *n n'*, and detachable sections *N N'*, substantially as specified.

4. The combination with the vertically-movable coffer-dams sections *N N'*, of the endwise-movable saws *S*, substantially as specified.

In testimony that I claim the above I have hereunto subscribed my name in the presence of two witnesses.

WILSON SMITH.

Witnesses:

J. A. O'DELL,
JOHN DAILEY.