

H. TWITCHELL.  
Water-Wheel.

No. 167,956.

Patented Sept. 21, 1875.

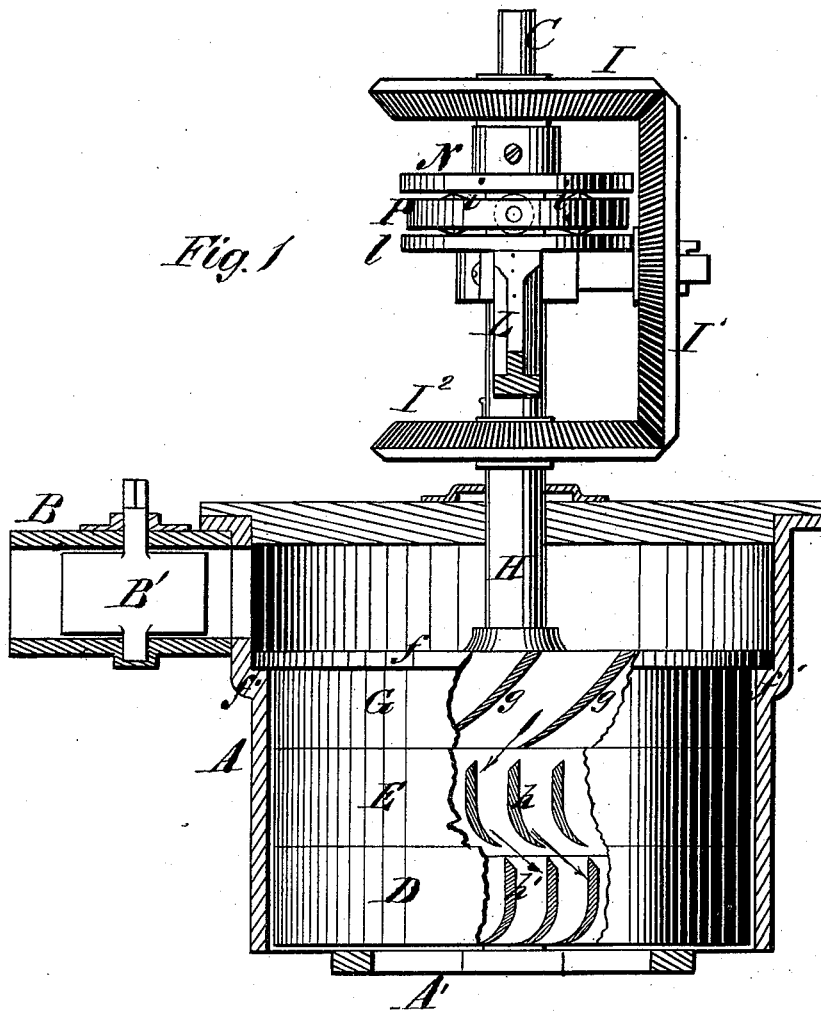

WITNESSES  
*E. H. Bates*  
*George C. M. Hanc.*

INVENTOR  
*Henry Twitchell,*  
*Chipman & Fournelle,*  
ATTORNEYS

H. TWITCHELL.  
Water-Wheel.

No 167,956.

Patented Sept. 21, 1875.

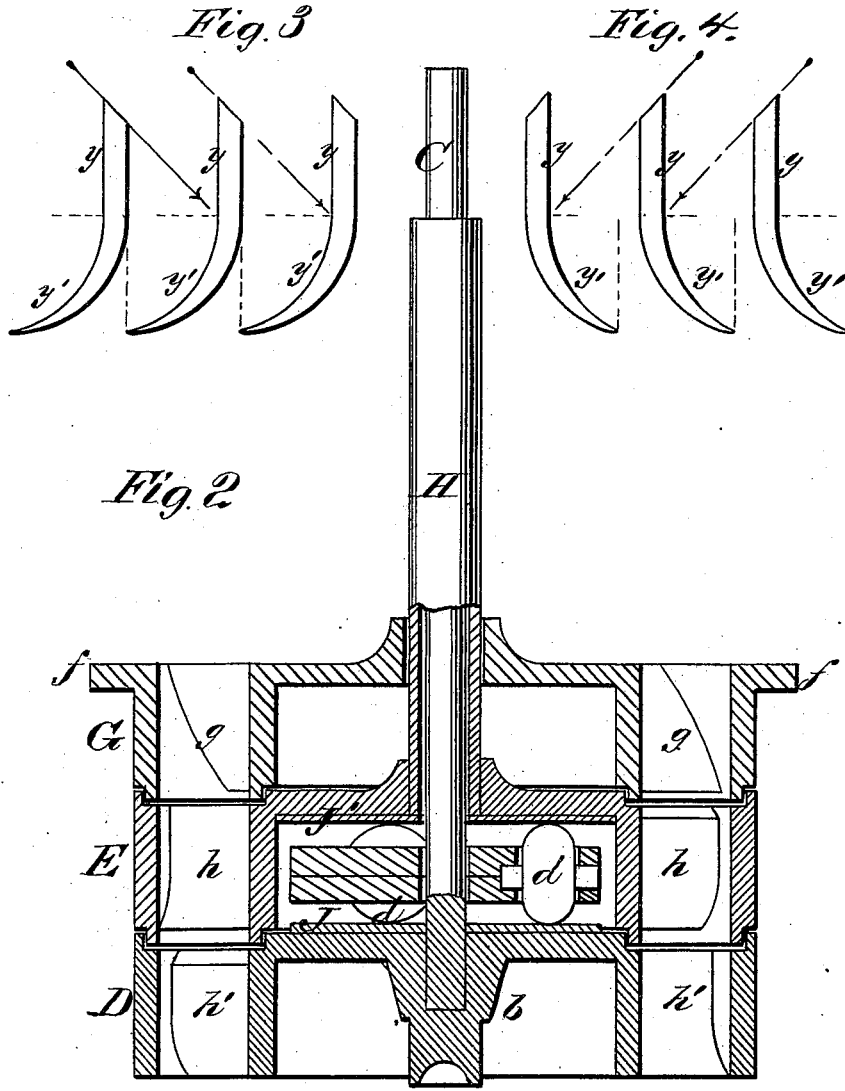

WITNESSES  
*E. H. Bates*  
*George C. Alpha.*

INVENTOR  
*Henry Twitchell*  
*Chipman & Osburn & Co*  
 ATTORNEYS

# UNITED STATES PATENT OFFICE.

HENRY TWITCHELL, OF PULASKI, NEW YORK.

## IMPROVEMENT IN WATER-WHEELS.

Specification forming part of Letters Patent No. 167,956, dated September 21, 1875; application filed June 19, 1875.

*To all whom it may concern:*

Be it known that I, HENRY TWITCHELL, of Pulaski, in the county of Oswego and State of New York, have invented a new and valuable Improvement in Water-Wheels; and I do hereby declare that the following is a full, clear, and exact description of the construction and operation of the same, reference being had to the annexed drawings making a part of this specification, and to the letters and figures of reference marked thereon.

Figure 1 of the drawings is a representation of a vertical section of my water-wheel, and Fig. 2 is a sectional detail view of the same. Figs. 3 and 4 are detail views.

This invention has relation to turbine water-wheels wherein two or more wheels are employed, arranged one above the other on different shafts, and so constructed that the water leaving one wheel will react on the one next below it.

The nature of my invention consists in the employment of two or more wheels rotating in opposite directions and on different shafts, in combination with anti-friction rollers and plates, as will be hereinafter more fully set forth.

In the annexed drawings, A designates a cylindrical upright curb, the lower end of which is open for allowing a free discharge of water, and the upper end of which is closed except where a chute, B, enters it for supplying water to the wheels. A gate, B', in the chute B is used for regulating the flow of water into the curb. C designates a central solid shaft, the lower end of which is secured centrally into the hub *b* of a wheel, D, which hub bears upon an elevation rising from a spider, A', fixed to the lower end of the curb. The shaft C and wheel D thus turn together. Above the wheel D is another wheel, E, and above this wheel E is a stationary wheel, G. The three wheels are rabbeted together, as clearly shown in Fig. 2, for the purpose of preventing lateral escape of water. The wheel E rotates in an opposite direction to the wheel D, and this wheel E is fast on a tubular shaft, H, which receives through it the shaft C, and with this shaft passes up through the cap of the curb, and has a beveled spur-wheel, I, keyed on it. J designates a chilled-metal cir-

cular plate, which is secured in a suitable manner on top of the central portion of the lowermost wheel D; and J' is a similar plate, which is secured to the bottom of the central portion of the wheel E. Between these plates J J' are spheroidal rollers *d*, which afford anti-friction bearings for the wheel E upon the wheel D, which rollers are journaled in a disk that is free to turn around the shaft C. By these means there will be comparatively little friction between the two wheels D E. Above the wheel E, and rabbeted on the upper edges of the rims thereof, is the wheel G, which is constructed with a flange, *f*, that rests upon an annular shoulder, *f'*, formed inside of the curb A. This wheel G is stationary, and it is formed with inclined guides *g*, which direct the inflowing water against the buckets *h* of the wheel E. The guides *g* are arranged at regular intervals apart, and are inclined at an angle of about forty-five degrees. The buckets *h* of the wheel E are inclined in a direction opposite to the direction of inclination of the guides *g*, and the buckets *h'* of wheel D are inclined in the same direction as the guides *g*. The guides, as well as the buckets, may be cast with their respective wheels.

Fig. 3 shows clearly the form of the buckets of both wheels D E. Each bucket has a vertical straight portion, *y*, against which the water impinges and acts by impact, which straight portion terminates below in a curved and tapered portion, *y'*, on which the water operates by its weight to turn the wheels. The upper end of each bucket is beveled like a chisel-edge, so as not to offer any resistance or interruption to the inflowing water. The wheel I on the shaft C engages with a corresponding wheel, I<sup>1</sup>, on a short shaft which is formed on the circular portion *l* of an arch, L. The wheel I' turns loosely around its shaft, and engages with a wheel, I<sup>2</sup>, which is keyed fast on the shaft H. By these means the two wheels D and E, which turn in opposite directions, will give shaft C rotary motion in one direction. N designates a disk, which is keyed on the upper end of the tubular shaft H, and which is supported upon rollers *i*, which are free to roll upon the circular portion *l*, and which are journaled in a turn-table, P. By these means the wheel E is suspended free

from the wheel D, and undue friction is prevented.

What I claim as new, and desire to secure by Letters Patent, is—

The wheels D and E, rotating in opposite directions and on different shafts, in combination with the anti-friction rollers *d* and plates J J', substantially as and for the purpose set forth.

In testimony that I claim the above I have hereunto subscribed my name in the presence of two witnesses.

HENRY TWITCHELL.

Witnesses:

GEORGE E. UPHAM,

WALTER C. MASI.