

L. W. BROADWELL.
Gas-Check for Ordnance

No. 167,981.

Patented Sept. 21, 1875.

Fig. 1

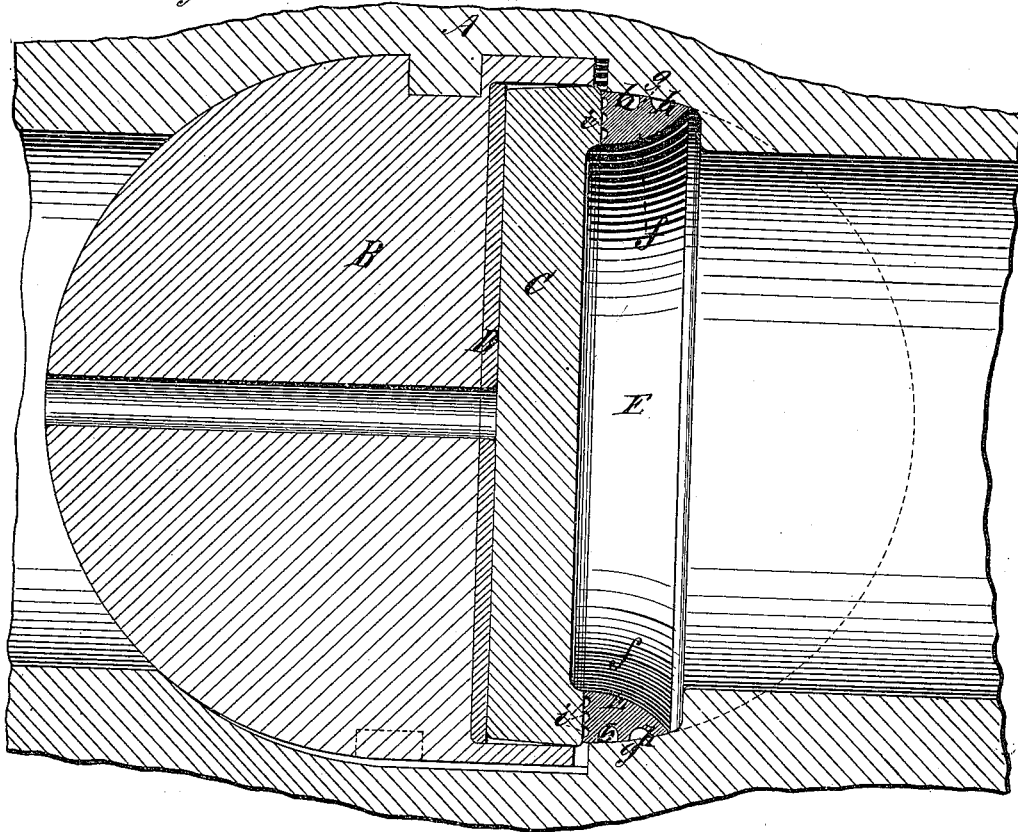
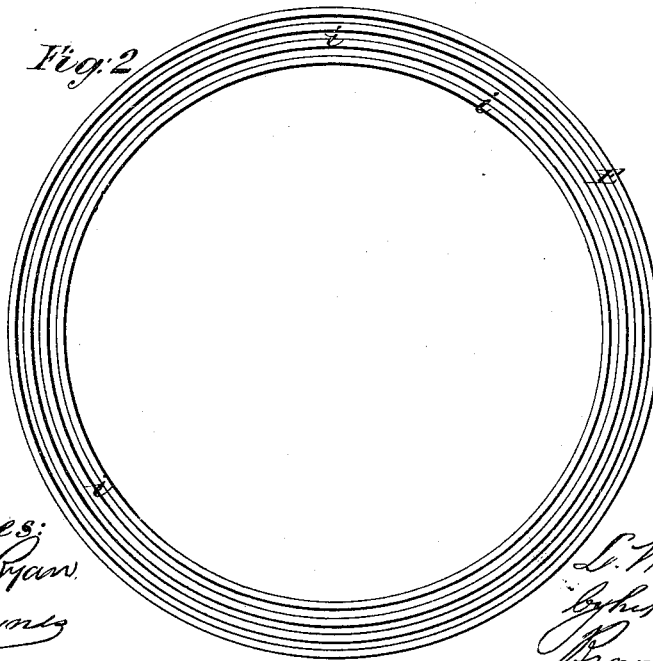

Fig. 2



Witnesses:
Michael Ryan
Geo. Haynes

L. W. Broadwell
By his Attorneys
Brown & Allen

UNITED STATES PATENT OFFICE.

LEWIS W. BROADWELL, OF HEITZING, NEAR VIENNA, AUSTRIA.

IMPROVEMENT IN GAS-CHECKS FOR ORDNANCE.

Specification forming part of Letters Patent No. 167,981, dated September 21, 1875; application filed May 31, 1875.

To all whom it may concern:

Be it known that I, LEWIS WELLS BROADWELL, a citizen of the United States, now residing at Heitzing, near Vienna, in the Empire of Austria, have invented an Improved Artillery Gas-Check: and I do hereby declare that the following is a full, clear, and exact description of the same, reference being had to the accompanying drawing, which forms part of this specification.

My invention consists in a novel construction of a gas-ring, whereby it is rendered more capable of sustaining the enormous gas-pressure, and, whereby, also, a greater amount of elasticity is imparted, the friction-surface is reduced, and means provided for preventing the accumulation of dust or other improper substance between the ring and its seat.

In the accompanying drawing, Figure 1 is a sectional view of a portion of the breech of a gun, with my improved gas-ring attached. Fig. 2 is a rear view of the ring.

A represents the breech, B the breech-block, C the recoil-plate, and D the copper backing-plate, interposed between the breech-block and recoil-plate, all of which parts may be constructed as described in patents heretofore granted to me, or may be of any other suitable construction.

My improved gas-check consists of a ring, E, having the form, in its cross-section, of a double arch, each arch having the other for a base, said arches being convex instead of concavo-convex, as heretofore.

The internal arch *f* enables the ring to sustain the enormous gas-pressure, and prevents the front thin edge from curling or bending inwards, so as to allow the escape of gas between the ring and its chamber, by which construction I obviate a difficulty sometimes experienced with a ring having its internal surface concave, as it is impossible for such de-

formity to take place in a ring constructed as hereinabove described.

The external shape of the ring is that of a section of a sphere whose diameter is equal, or nearly so, to the greatest diameter of the ring.

On the external arch or curved surface *g* I form one, two, or more grooves, *h*, extending entirely around the circumference of said curved surface. The number of these grooves and their depth and width depend upon the caliber of the gun to which the ring is to be applied. The object accomplished by them is threefold: first, they impart a greater amount of elasticity than would exist if the curved surface were not grooved; second, they reduce the friction-surface, and thus facilitate the quick rearward action of the ring upon its bearing-plate to close the joint; third, they form reservoirs which receive all dust or other improper substance which may enter the chamber, and prevent the accumulation thereof between the ring and its seat. On the rear side of the ring is a series of concentric grooves, *i*, such as have been described in Letters Patent No. 55,762, granted to me June 19, 1866.

What I claim as new, and desire to secure by Letters Patent, is—

1. The gas-ring, having the internal arch or convex surface *f*, substantially as herein described.

2. The combination, in a gas-ring, of the internal and external arches *f g*, substantially as and for the purpose described.

3. The groove or grooves *h*, in the external convex surface or arch *g*, substantially as and for the purposes described.

L. W. BROADWELL.

Witnesses:

PHILIP SIDNEY POST,
WILLIAM HÜNING.