

G. W. CHAMBERLIN & S. G. CUSHING.
 Machine for Cutting Wood Screws.

No. 167,988

Patented Sept. 21, 1875.

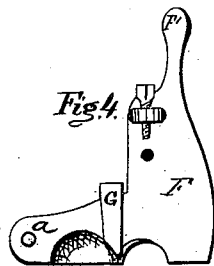
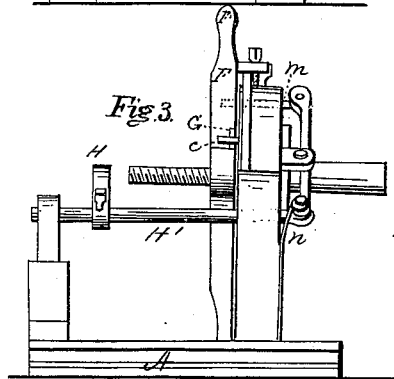
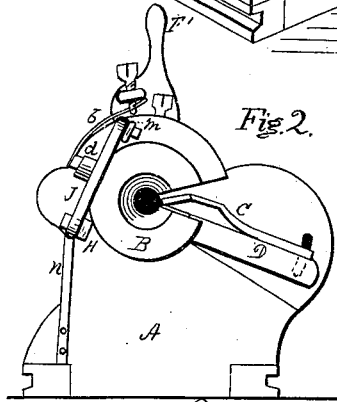
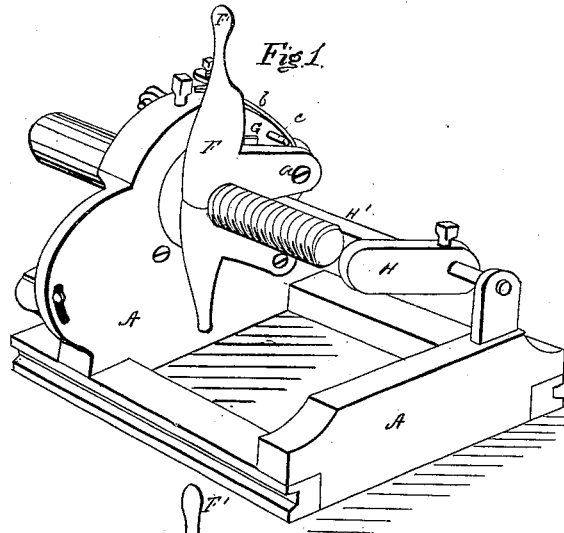

Witnesses:
F. B. Townsend.
James Stevenson.

Inventor:
Geo. W. Chamberlin
Sevell B. Cushing
per attys
A. H. Evans & Co.

UNITED STATES PATENT OFFICE.

GEORGE W. CHAMBERLIN AND SEWELL G. CUSHING, OF FITCHBURG,
MASSACHUSETTS; SAID CHAMBERLIN ASSIGNOR TO SAID CUSHING.

IMPROVEMENT IN MACHINES FOR CUTTING WOOD-SCREWS.

Specification forming part of Letters Patent No. 167,988, dated September 21, 1875; application filed
September 4, 1875.

To all whom it may concern:

Be it known that we, GEORGE W. CHAMBERLIN and SEWELL G. CUSHING, both of Fitchburg, Massachusetts, have invented certain new and useful Improvements in Machines for Cutting Wood-Screws, of which the following is a full, clear, and exact description, reference being had to the accompanying drawings, making a part of this specification, in which—

Figure 1 is a perspective view, showing the screw-cutting dies in position. Fig. 2 is an end view. Fig. 3 is a side view. Fig. 4 is a detached view of one of the dies, showing the cutting-knife.

Where screws are cut with a solid die, the screw when finished has to be turned backward until it clears the die before it can be removed from the machine.

Now, the object of our invention is to remove the screw at once after it has been cut, so as to save time, and we save half the time consumed by a machine in which is used the solid die.

Our invention is designed for use or connection with a lathe, but it may be detached therefrom and used separately.

Our invention consists in a die divided into two parts, and which may be used either separately or together.

In the drawings, A A represent the common frame-work of a screw-cutting machine. The ring B, cutting-tool C, and its adjustable tool-bed D are also common features in this class of machines. The first feature of our invention is the half-die F, which holds the cutter G. This die is pivoted at *a* to the frame A, and its upper part constitutes a handle, F', for setting the die and cutter in position. When these are not in use they are held up out of position by means of a spring, *b*, and its tension is so strong that it will instantly throw the die up out of place against

a stop-pin, *c*, when the screw-thread has been cut the desired length, at which time the screw, being fed forward, presses upon the gage, which with its intermediate mechanism instantly releases the die. H represents the gage, which, by means of a set-screw, may be set on the gage-rod H', so that a thread may be cut of any length. This rod lies loosely in bearings on the sides of the frame-work A A. Upon one end of this rod, outside the frame A, is attached one end of a lever, I, pivoted at its center to a fulcrum, *d*, on the frame A. On the opposite end of the lever is a pin, *m*, which, by means of a spring, *n*, is thrown inward, so as to enter a hole in the die-handle, whenever the handle is pulled downward. It is the pin which holds the die in place, and it is by an automatic withdrawal of the pin that the die and cutter are thrown up out of place. Then the wood-screw may be easily withdrawn by hand.

In Fig. 1 we have shown a double die. Both dies may be pivoted to the frame on the same fulcrum, and at pleasure either one may be removed from contact with the screw; but the lower die is not an essential feature of our invention.

Having thus described our invention, what we claim as new, and desire to secure by Letters Patent, is—

1. In a wood-screw-cutting machine, a die, F, in combination with the cutter G, substantially as and for the purpose set forth.

2. The combination of the gage H and gage-rod H' with the lever I, spring *n*, and pin *m*, for automatically operating the dies, substantially as set forth.

GEORGE W. CHAMBERLIN.
SEWELL G. CUSHING.

Witnesses:

CHARLES T. CUSHING,
WILLIAM A. CARLETON.