

O. F. COMFORT.

Door-Spring.

No. 167,989.

Patented-Sept. 21, 1875.

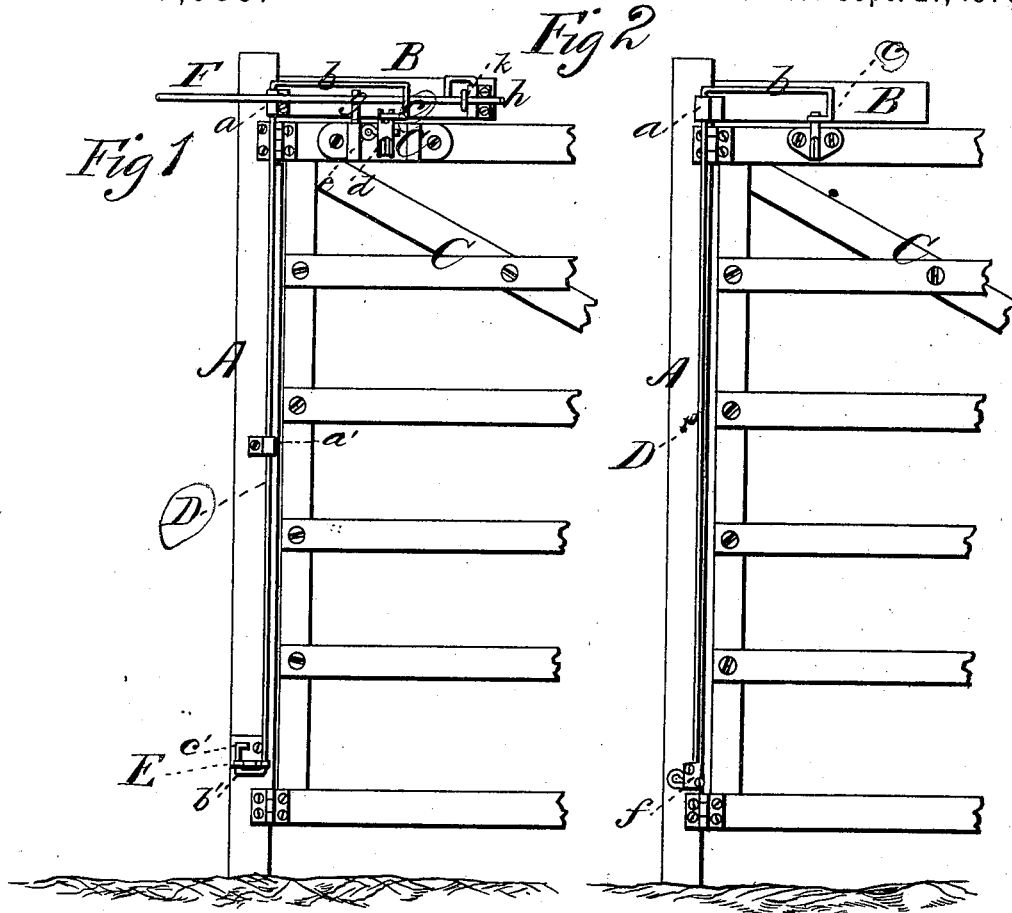
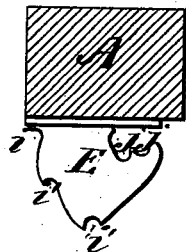

Fig 3



WITNESSES

Robert Everett  
E. H. Bates

INVENTOR

Orrin F. Comfort,  
Chepman & Francis Co.,  
ATTORNEYS

# UNITED STATES PATENT OFFICE.

ORRIN F. COMFORT, OF EVANSVILLE, WISCONSIN.

## IMPROVEMENT IN DOOR-SPRINGS.

Specification forming part of Letters Patent No. **167,989**, dated September 21, 1875; application filed July 3, 1875.

*To all whom it may concern:*

Be it known that I, ORRIN F. COMFORT, of Evansville, in the county of Rock and State of Wisconsin, have invented a new and valuable Improvement in Door-Springs; and I do hereby declare that the following is a full, clear, and exact description of the construction and operation of the same, reference being had to the annexed drawings, making a part of this specification, and to the letters and figures of reference marked thereon.

Figure 1 of the drawings is a representation of a plan view of my door-spring, and Fig. 2 is a modification thereof. Fig. 3 is a sectional detail view.

This invention relates to improvements in torsion door-springs, which are designed to cause a door to be automatically closed after being opened; and the nature of the invention consists in combining, with a torsion-spring mounted in suitable bearings, a notched adjusting-plate arranged upon the door-jamb near its lower part, whereby the strength of the spring may be increased or diminished, as the necessities of the case may require. It also consists in combining, with a torsion-spring, the upper end of which extends from the jamb over the top rail of the casing, thence downward beyond the upper edge of the door, a horizontally-vibrating lever having its fulcrum on the said top rail, and a spurred catch upon the upper edge of the door with which the torsion-spring engages, whereby the door, when opened at an angle of ninety degrees or less, will be automatically closed, and when opened beyond the arc of ninety degrees will be held open, as will be hereinafter more fully explained.

In the annexed drawings, A designates the jamb of a door-casing; B, the top rail, and C the door closing the opening, and hinged to the jamb. D represents my improved torsion-spring, which is of the usual length, and has its bearings in flat metallic loops *a a'*, secured, respectively, on the top rail and jamb of the casing. The upper end of spring D has an extension, *b*, at right angles to its length, on the end of which is formed a rectangular hook, *c*, and the lower end of the said spring has a similar extension, *b'*, of less length and in an opposite direction from extension *b*, and hav-

ing a similar hook, *c'*, upon its end, as shown in Fig. 1. The upper hooked extension *b* engages with a catch, C, rigidly secured upon the upper edge of the door, the construction of which will be fully given hereinafter, and the lower hooked extension *b* is engaged with a notched plate, E, of the general form of a hook, which is rigidly secured to the door-jamb in a horizontal position. The outer edge of plate E is of segmental form, and is provided with two or more spaced notches, *i i'*, while its inner edge, which is also segmental, but concaved, has notches *j*, also spaced. The lower hooked extension *b'* is adapted to engage with one of these notches on each side of plate E, and is thereby locked against axial rotation, and a torsion-spring is the result. By shifting the end of extension *b* to an outer notch, *i'*, the power of the spring may be greatly increased.

In practice the catch C will be sectional, and the nose *d* will be U-shaped, and, having been placed on a raised rib on the base of the catch, will be secured in place by means of a pin, *e*. I sometimes also dispense with the lower extension and its adjusting device E, in which case the lower end of the spring will be locked to the jamb by means of a plate, *f*, which will be clamped against the said end by means of suitable screws.

When the door is thrown open in a position at right angles or less to its position when closed, the door, when released, will be instantly closed by the reflex action of the spring; but if it be opened beyond the angle of ninety degrees upper extension *b* will escape from the catch, and the former will spring back into its normal position. If the door be afterward closed, the catch and spring will be immediately re-engaged.

In order to utilize the force of spring D to hold the door open catch C is provided with a spur, *g*, extending upward between the arms of a horizontally arranged and vibrating lever, F, pivoted at *h* to the top rail. This lever extends under the hooked end of the extension, and it is endowed with a degree of spring by the confinement of its end in an eyebolt, *k*.

When the extension escapes from the catch when the door is widely opened the latter will spring back against the lever F, and the spur

*g* being engaged in the said lever the door will be held open at any degree of inclination by the restraint imposed by the spring *b*.

Lever *F* is preferably of wire, and it extends from its pivot *h* to and beyond jamb *A* of the door-casing. It is then bent backward to its hinge, and its free end confined in an eyebolt, *k*, before alluded to. By this means the lever *F* is, as it were, slotted, and a means is provided whereby the spur of the catch is connected therewith.

What I claim as new, and desire to secure by Letters Patent, is—

1. In a torsion door-spring, the combination of the spring *D*, having extensions *b b'* and hooks *c c'*, with the plate *E*, having notches *i, i'*, and *j*, substantially as specified.

2. The combination, with the spring *D*, having hooked extension *b* and spur *g*, for automatically releasing the spring, of the vibrating lever *F*, substantially as specified.

3. The combination, with a torsion-spring, *D*, of an upwardly-extending spur, *g*, upon the door, for automatically releasing the spring, and the horizontally-vibrating lever *F*, having its fulcrum upon the top rail, substantially as specified.

In testimony that I claim the above I have hereunto subscribed my name in the presence of two witnesses.

ORRIN FERRIS COMFORT.

Witnesses:

J. C. SHARP,

E. A. BENNETT.