

W. LYON.  
Rotary Engine.

No. 168,035.

Patented Sept. 21, 1875.

*Fig. 1.*

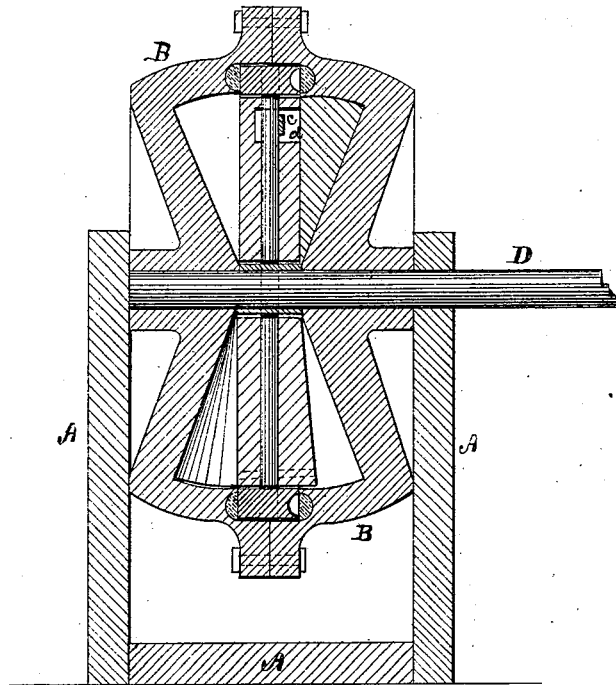

*Fig. 2.*

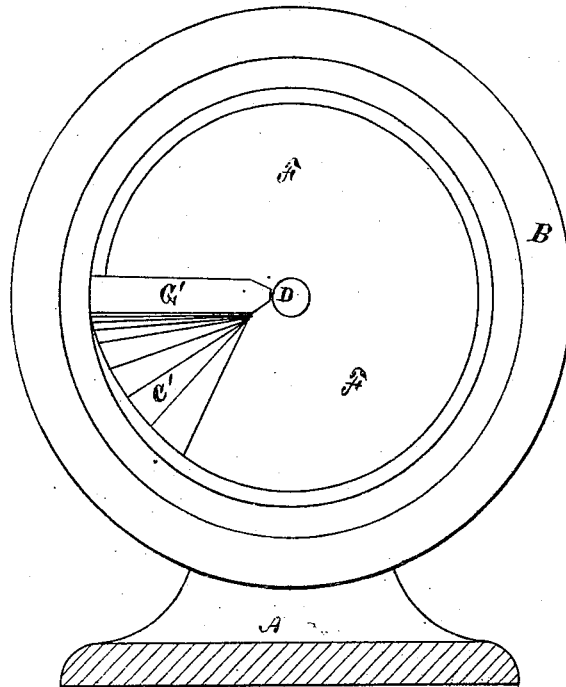

Witnesses  
Oliver Drake  
J. C. Tenbridge

Inventor  
W. Lyon

W. LYON.  
Rotary Engine.

No. 168,035.

Patented Sept. 21, 1875.

Fig. 3.

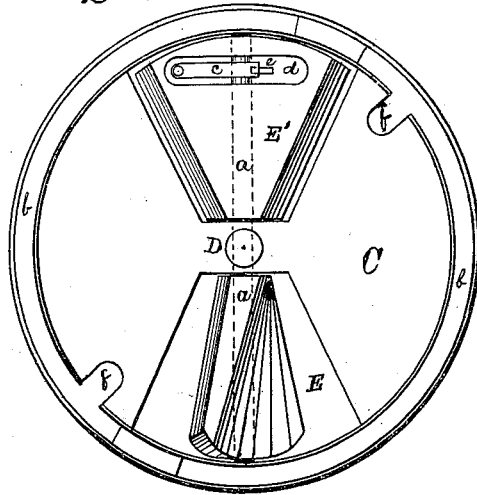
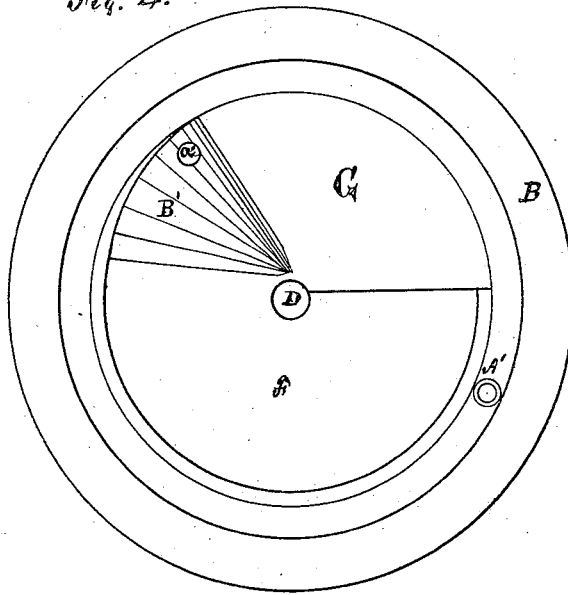

Fig. 4.



Witnesses

Oliver Drake  
J. C. Tunbridge

Inventor

Wm Lyon

# UNITED STATES PATENT OFFICE.

WILLIAM LYON, OF NEWARK, NEW JERSEY.

## IMPROVEMENT IN ROTARY ENGINES.

Specification forming part of Letters Patent No. 168,035, dated September 21, 1875; application filed August 26, 1875.

*To all whom it may concern:*

Be it known that I, WILLIAM LYON, of the city of Newark, in the county of Essex and State of New Jersey, have invented certain new and useful Improvements in Rotary Engines; and I do hereby declare that the following is a full, clear, and exact description thereof, which will enable others skilled in the art to which it pertains to make and use the same, reference being had to the accompanying drawing, and to the letters of reference marked thereon, which form a part of this specification.

The nature and object of this invention are the construction of a rotary engine having its piston so arranged and operating as to be self-packing, thereby avoiding the necessity of so frequently taking the engine apart in order to pack it.

My invention consists in the construction of a rotating or revolving disk or partition provided with oscillating segmental plates or piston, said disk or partition being centrally located in a case, which is made in two parts, and revolving therein, the whole being constructed, arranged, and operating substantially as hereinafter set forth and described.

In the accompanying drawing, Figure 1 is a vertical cross-section of a rotary engine combining and illustrating my improvements. Figs. 2 and 4 are inverted views of the two sides of the case, and Fig. 3 is a plan view of the central revolving disk or partition provided with the oscillating segmental plates or piston.

A is the frame-work which supports the engine. B is the casing, which is provided with suitable inlet and exhaust ports for the steam. C is the central partition or disk, which is rigidly secured to a shaft, D, and revolves therewith, and is provided with oscillating segmental plates or piston E and E', which are conformed to the chambers in the case B, which is made in two parts, their insides being conically formed, and, by their juxtaposition at their outer edges and at the center with the revolving partition C, form the chambers F, and in which said disk revolves, and the piston or segmental plates have a rocking or oscillating motion, as above set forth. Said segments E and E' are ad-

justed upon a shaft, *a*, though in different positions, as indicated in Figs. 1 and 3, the segment E being rigidly secured to said shaft *a*, and the opposite segment E' being loose thereon, but kept in position and prevented from turning by means of a spring, *c*, secured in a groove, *d*, in said segment, and pressing upon a pin, *e*, projecting from said shaft *a*, as shown in Fig. 3, thereby not only preventing it from turning from its position on the shaft, but acting upon said segments E and E' in such manner as to continually press them against the sides of the chambers, insuring tight joints therewith and compensating for the wear and tear upon the parts.

As the disk C revolves and passes the center one of the segments comes in contact with an inclined plane, B, and is forced into a position in line with the face of the disk C, leaving the exhaust-chamber open. At the same time the other segment, also coming in contact with an inclined plane, C', is turned diagonally across the chamber on the opposite side, closing it up, the segments remaining in the same relative positions until passing the center, when the operation is repeated. As the steam enters the inlet-port A' it passes into an annular groove, *b*, in the face of the disk C, and from thence, through suitable outlets *f*, into the chamber F, when it comes in contact with the segments alternately as the disk C revolves.

It will be observed that about one-third of the space in the inside of one of the parts of the case B, (designated by the letter G,) and to which the inclined plane B' leads, is filled up even with the face of the disk, forming a close joint therewith, and, in conjunction with the partition G' in the opposite side, divides the inlet from the exhaust-chamber.

It will also be observed that both sides of the case are provided with inclined planes B' and C', upon which the segments E and E' ride in changing from one position to another in the chamber, thereby avoiding concussion and jar from the motion of said segments.

Having thus described my invention, what I claim as new, and desire to secure by Letters Patent of the United States, is—

In a rotary engine, the combination, with the case B, constructed as described, of the revolving disk C, provided with the segments E and E', operating in conjunction therewith, substantially as and for the purposes set forth.

In testimony that I claim the foregoing as

my own invention I affix hereto my signature in presence of two witnesses.

WILLIAM LYON.

Witnesses:

OLIVER DRAKE,  
J. C. TUNBRIDGE.