

A. M. WADE. Machine for Spooling Yarn.

No. 168,066.

Patented Sept. 21, 1875.

Fig. 1.

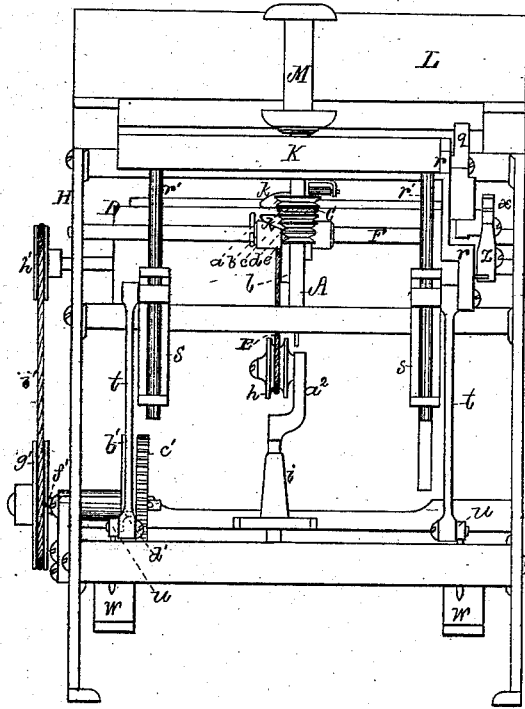

Fig. 2.

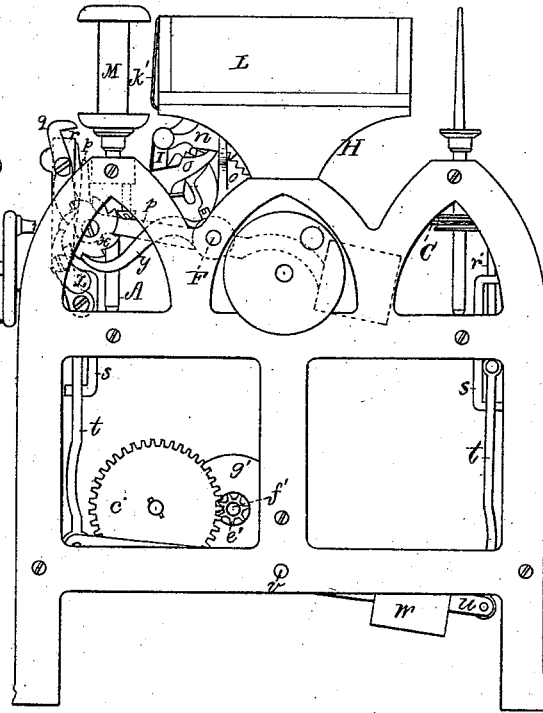
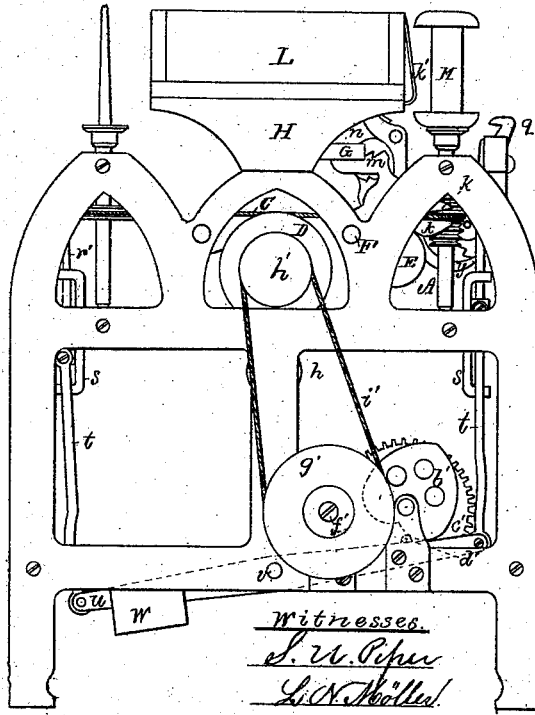
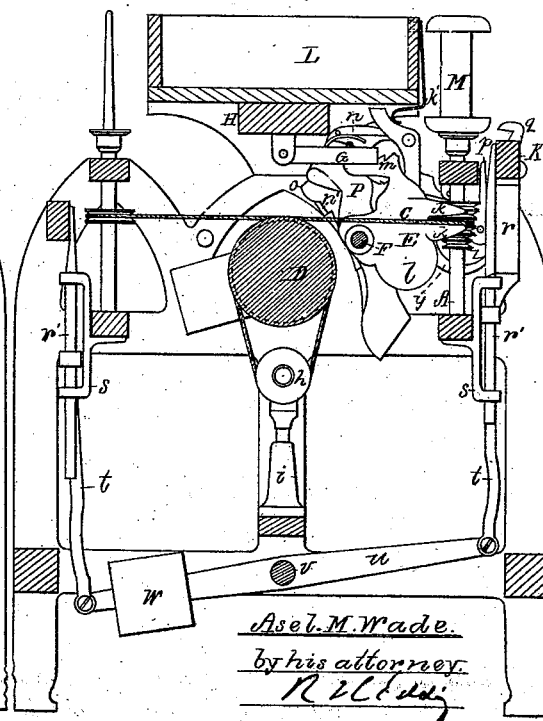

Fig. 3.



Witnesses.
S. W. Piper
L. N. Keller

Fig. 4.



A. M. Wade.
by his attorney.
R. C. Deitz

A. M. WADE.
Machine for Spooling Yarn.

No. 168,066.

Patented Sept. 21, 1875.

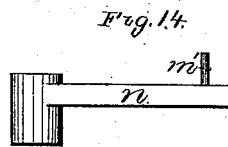
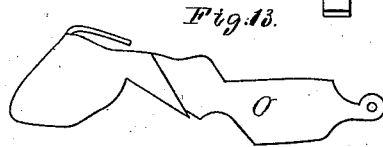
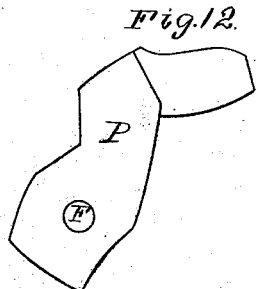
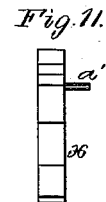
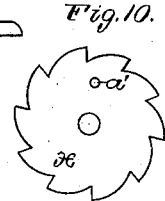
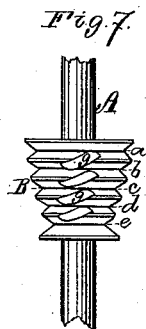
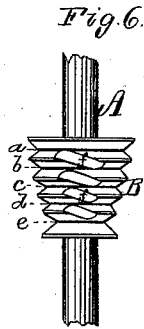
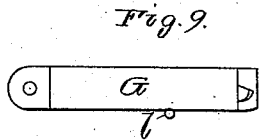
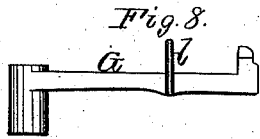
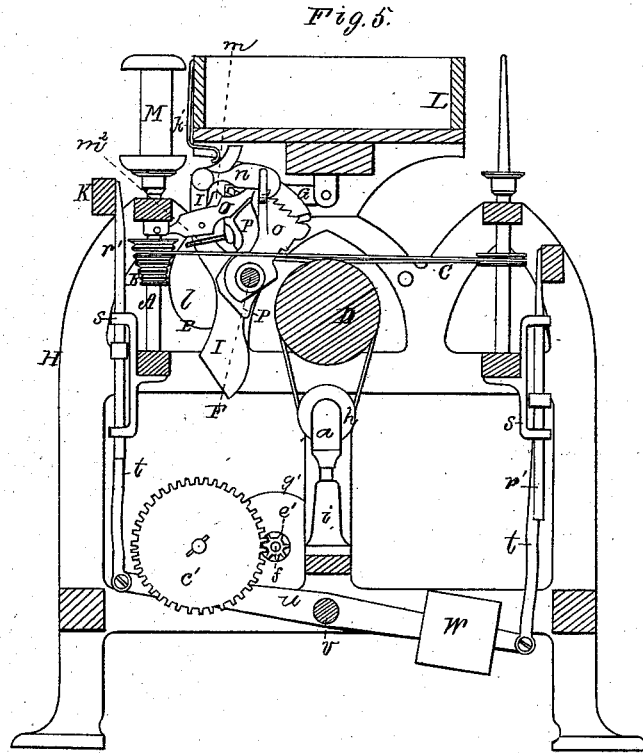

Witnesses.
S. W. Piper
L. W. Hodder

A. M. Wade
 by his attorney
R. H. Eddy

UNITED STATES PATENT OFFICE.

ASEL M. WADE, OF LAWRENCE, MASSACHUSETTS.

IMPROVEMENT IN MACHINES FOR SPOOLING YARNS.

Specification forming part of Letters Patent No. **168,066**, dated September 21, 1875; application filed July 3, 1875.

To all whom it may concern:

Be it known that I, ASEL M. WADE, of Lawrence, in the county of Essex and State of Massachusetts, have made a new and useful invention, having reference to Machinery for Spooling or for Spinning and Winding Yarn; and do hereby declare the same to be fully described in the following specification and represented in the accompanying drawings, of which—

Figure 1 is a front elevation, Figs. 2 and 3 opposite side elevations, and Figs. 4 and 5 transverse sections, of a spooling-machine provided with my said invention, it being shown as applied to one only of the spindles.

The sections termed Figs. 4 and 5 are taken on opposite sides of the spindle, in order to exhibit side views of the mechanism in rear of said spindle.

The object of the mechanism constituting my invention is to revolve the spindle slower as the yarn-load of the spool may increase in diameter—in other words, to so revolve the spindle as to cause equal increments of load to be wound in equal times. When the velocity of the spindle or spool is uniform it will be readily seen that, as the load may increase in diameter, the greater will be the amount of load wound in a given time.

My improvement enables me to effect the winding of the load in very much less time than by the ordinary mode of winding at a uniform velocity of the spindle.

In carrying out my invention, I provide the spindle (shown at A, in the drawings,) with a conical pulley, B, having a series of grooves, *a b c d e*, for instance, going around it in its periphery.

Figs. 6 and 7 are opposite side views of such grooved pulley. Each of the grooves has two inclined passages, *f g*, leading from it into the groove next below it, those on one side of the pulley being pitched or inclined in directions opposite to those of the other side, as will be seen by reference to said Figs. 6 and 7.

At the expiration of each of a given number of intervals of time during the winding of the load the endless band *a*, by which the spindle is driven, is to be caused to pass from one groove upward into the next one above, whereby the speed of the spindle will be reu-

dered slower during the succeeding interval than it was during that next preceding it. Furthermore, after the spool may have been properly filled, or the yarn-load may have been completed, the driving-band is to be run down from the upper to the lower groove of the pulley, in order to be ready for again revolving the spindle after it may have been provided with an empty spool.

The mechanism for producing such results I shall now proceed to describe.

The endless band for driving the spindle is carried around two opposite spindle-pulleys and over the driving-drum D; thence it goes in opposite directions over the drum, and down under a grooved wheel, *h*, supported on a journal projecting from a carrier, *a*², arranged to slide vertically on a stationary standard, *i*, arranged as shown. The pulley and carrier, by being capable of being moved up and down, serve to keep the driving-band tight, and they allow it to be moved by the stopper, as occasion may require. The band passes between the prongs *k k* of a bifurcated shipper, E, that turns freely on a horizontal shaft, F. This shipper is heavily weighted, as shown at *l*, and has a toothed rack, *m*, extending from it in manner as represented. With this rack a catch-pawl, G, engages, it being shown in top view in Fig. 8, and in inner-side view in Fig. 9. At its rear the said pawl is pivoted to the frame H of the machine.

From the shipper E a hook, *m*², (see Fig. 5,) extends partially around the upper arm of a lever, I, whose fulcrum is the shaft F. To the said arm there is pivoted a weighted or heavy hooked pawl, *n*, which rides upon a toothed sector, *o*, projecting upward from and fastened to the shaft F. From the said shaft a tripper or bent arm, *p*, formed as shown, is extended toward a weighted-lever catch, *q*, pivoted to a bracket, *r*, that projects down from a horizontal bar, K, arranged as represented.

From the bar K guide-rods *r r* extend down vertically through stationary brackets *s s*. Connection-rods *t t*, pivoted to the said rods, connect them with two levers, *u u*, having a common supporting-shaft, *v*, and being provided with weights *w w*, arranged as represented. Furthermore, there is pivoted to the tripper *p* a ratchet-wheel, *x*, arranged directly

over a weighted lever-catch or retaining-pawl, *y*, that has the shaft F for a fulcrum. To intermittently revolve the ratchet-wheel *x* there is an impelling lever-pawl *z*, that is pivoted to the bracket *r*.

Fig. 10 is an inner side view, and Fig. 11 an edge view, of the ratchet-wheel *x*, which is provided on its inner side with a small stud, *a'*, that projects from it in manner as represented.

During each revolution of the ratchet-wheel the stud *a'* will be forced against the weighted tail of the hooked lever-catch *q*, and thereby move the catch, so as to cause it to take upon the contiguous end of the tripper *p*. The bar K is to have reciprocating vertical movements, such being effected by means of the weighted levers *u u* and a cam, *b'*, the latter being fixed to a gear, *c'*, and having borne up against its periphery a stud, *d'*, projecting from one of the levers *u u*. The said gear engages with a pinion, *e'*, whose shaft *f'* is provided with a grooved wheel, *g'*, around which and another grooved wheel, *h'*, fixed on the shaft of the drum D, an endless band, *i'*, passes, the whole being to communicate rotary motion to the aforesaid cam, and, as a consequence, produce reciprocating vertical movements of the bar K. During each upward movement of the said bar the ratchet-wheel *x* will be partially revolved. After such ratchet-wheel may have moved the catch *q*, such catch, during the next downward movement of the bar K, will take upon the tripper *p* and pull it downward, so as to cause it to turn the shaft F. Directly in rear of the spindle there is pivoted to the spool-box L a vibratory or swinging arm, *k'*, shaped as shown. Every time the shaft F is turned forward it will simultaneously advance its toothed sector *o*. The pawl *n* and the upper arm of the lever I will simultaneously move forward, and the arm will force the vibratory arm *k'* up to the load of yarn on the spool M. On meeting the load the arm *k'* can go no farther, and consequently will act as a stop to arrest the advance of the said lever-arm. The toothed sector will continue in movement until it may have passed the length of a tooth of it underneath the hooked pawl *n*. This done, when the toothed sector next may recede, it will, by means of the catch-pawl, pull back the lever, which, in turn, acting against and through the hook of the shipper will raise the said shipper, so as to cause it to force up the driving-band. While being so pressed upward the band will take into the next succeeding groove of the pulley of the spindle, it being caused to do this by the inclined groove connecting the two grooves.

Thus it will be seen that during each entire revolution of the ratchet-wheel the shipper will be lifted up, so as to cause the driving-belt of the pulley to ascend into a higher groove, and while therein it will revolve the spindle at a less speed than it did when in the groove next below.

The succeeding part of the mechanism to be

described is that which, on the spool-load having been completed, is to effect the sudden transfer of the driving-band from the uppermost to the lowermost groove of the driving-pulley. Such part I term the pawl-detacher, and its elevator, they being represented in side views in Figs. 12 and 13, and at O and P in Fig. 5.

The detacher O is pivoted to the spindle-bolster rail, so as to play vertically, the elevator P being pivoted on the shaft F and arranged in the plane of the detacher, which is directly against the lever I. The pawl G has a stud, *l'*, extending inward from it, as seen in Fig. 8; and the pawl *n* also has a stud, *m'*, projecting inward from it, as seen in Fig. 14, which is a top view of such pawl. The sector *o* has a stud, *n'*, extending inward from it to act against the elevator P at the proper time.

After the yarn-load may have been completed the stud *n'* of the sector *o* will be forced against the elevator, and will press it toward and against the detacher, and force up the latter in a manner to cause it, by means of their studs, to elevate both pawls out of engagement with the sector and rack, in order to allow the weight of the shipper to move the shipper, so as to cause it to depress the driving-band, and in the meantime pull forward the lever I. The driving-band will run down from the upper to the lower groove of the spindle-pulley.

I claim—

1. The combination, with the spindle-grooved conical pulley B, as described, and the belt-shipper E, of mechanism, substantially as specified, for periodically moving the shipper E, whereby the driving-band is caused to move successively from one groove up into the next one of a series of grooves, *a b c d e*, of said pulley, such mechanism consisting of the rack *m* and its catch-pawl G, the hook *m'*, lever I, hooked pawl *n*, toothed sector *o*, shaft F, tripper *p*, catch *q*, reciprocating bar K, (provided with mechanism for operating it as described,) ratchet-wheel *x*, retaining-pawl *y*, lever-pawl *z*, stud *a'*, and vibrating arm *k'*, all applied and arranged substantially as shown and set forth.

2. The combination of the spindle-grooved conical pulley B, as described, the belt-shipper E, and the mechanism for periodically moving the shipper to cause the driving-band to be moved upward successively from groove to groove of said pulley B, with mechanism, substantially as described, which, on the spool load having been completed, causes the driving-band to pass from the highest down into the lowest of the grooves of the pulley, such mechanism consisting of the detacher O, elevator P, and the weight *l* of the shipper, all being constructed, applied, and arranged essentially as explained and represented.

3. The combination, for periodically moving the shipper E, whereby the driving-band is caused to be moved successively from one groove up into the next one of the series of

grooves of the conical and grooved spindle-pulley B, of the rack *m* and its catch-pawl G, the hook *m*², lever I, hooked pawl *n*, toothed sector *o*, shaft F, tripper *p*, catch *q*, reciprocating bar K, (provided with mechanism for operating it, as described,) ratchet-wheel *x*, retaining-pawl *y*, lever-pawl *z*, stud *a*', and vibratory arm *k*', all applied and arranged substantially as shown and set forth.

4. The combination of the detacher O, elevator P, and the weight *l* of the shipper, with the mechanism for periodically moving the

shipper E, whereby the driving-band is caused to be moved successively from one groove up into the other of the said pulley B.

5. The guide-wheel *h* and its gravitating-carrier *a*², in combination with the driving-band, the spindle-pulley, and the shipper, provided with mechanism for operating the shipper, as specified.

ASEL M. WADE.

Witnesses:

A. L. PERKINS,
D. B. RICKER.