

C. R. TURNER.
Smoked-Beef Shaver.

No. 168,433.

Patented Oct. 5, 1875

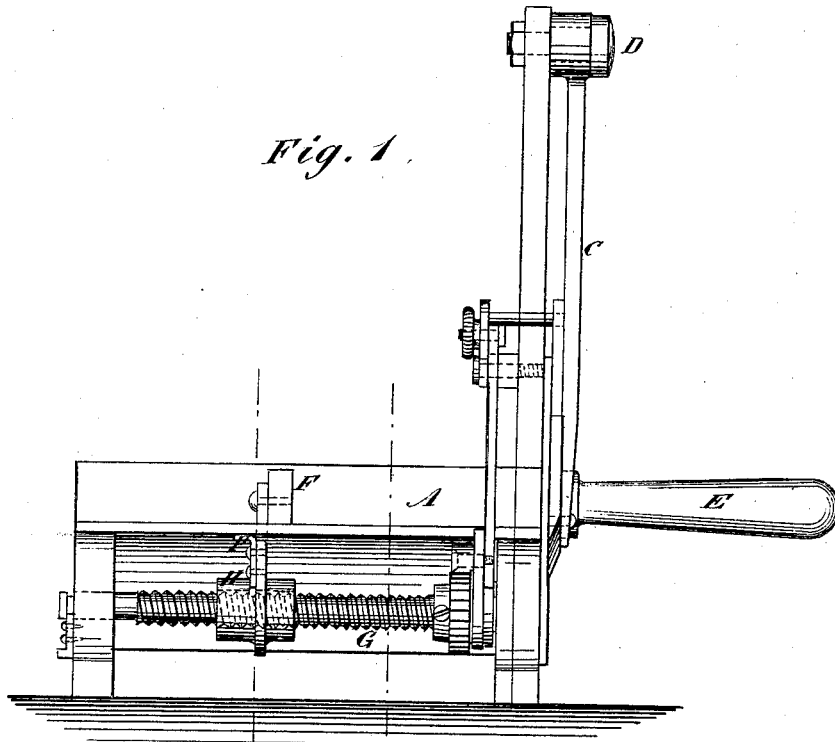

Fig. 1.

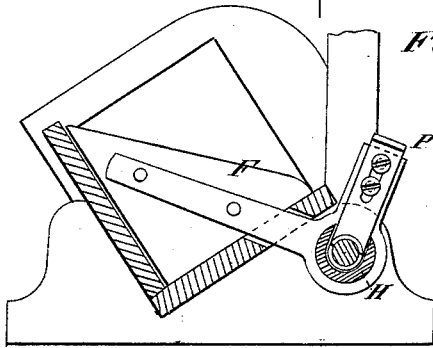

Fig. 3.

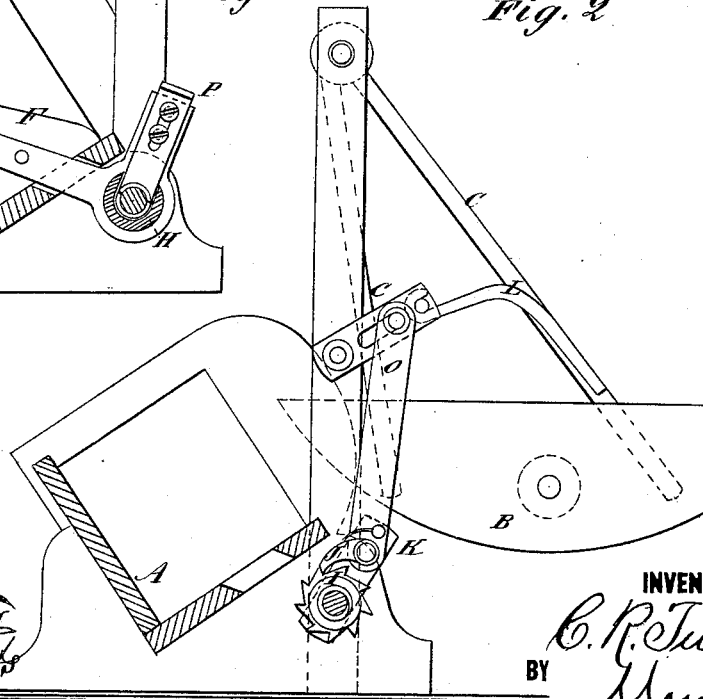

Fig. 2.

WITNESSES:
C. Nevada
Alex. F. Roberts

INVENTOR:
C. R. Turner
BY *Munroe*

ATTORNEYS.

UNITED STATES PATENT OFFICE

CALEB R. TURNER, OF BROOKLYN, NEW YORK.

IMPROVEMENT IN SMOKED-BEEF SHAVERS.

Specification forming part of Letters Patent No. **168,433**, dated October 5, 1875; application filed August 28, 1875.

To all whom it may concern:

Be it known that I, CALEB R. TURNER, of Brooklyn, in the county of Kings and State of New York, have invented a new and Improved Smoked-Beef Shaver, of which the following is a specification:

This invention consists of a slicing-knife swinging forward and backward at the end of a trough holding the beef, so as to shear-cut, the knife being suspended from a pivot above the trough, on which it can be swung up out of the way of the trough to be sharpened without being detached; and the knife-frame carries a cam, which feeds the meat up to the knife by turning a screw by a ratchet mechanism, which screw works a pusher in the trough behind the meat. The pawl mechanism is contrived to vary the feed, making thick or thin slices, and the pusher is so engaged with the feed-screw that it can be shifted along the screw quickly to adjust it to the meat.

Figure 1 is a side elevation of the machine. Fig. 2 is a transverse section taken on line *x*, and Fig. 3 is a transverse section taken on line *y y*.

Similar letters of reference indicate corresponding parts.

A is the trough for holding the beef to be sliced. It is preferably of V shape, which is better for holding pieces of different sizes than any other form. B is the knife for slicing the beef. It is attached to the swinging frame C, which turns on the pivot D, so that the knife

swings forward and backward close to one end of the trough, and shears off the slices. E is a handle, attached to the swinging frame for working it. F is the pusher for feeding the beef along to the knife. It is connected to the feed-screw G by the nut H, and the feed-screw is worked by ratchet I, pawl J, and lever K, and the lever is worked by the cam L on the swinging frame C, slotted lever M, and the connecting-rod O, the lever being slotted for the connection of the rod, so that the latter may be shifted along to vary its throw, and thereby vary the feed for making the slices thick or thin, as may be required. The nut H is contrived to gear with the screw by the sliding piece P, so that by pulling said piece out of the threads of the screw the nut is freed therefrom to allow the pusher to be shifted along in the trough, as may be required, for adjusting it to the work to save the time it would require to shift it by turning the screw.

Having thus described my invention, I claim as new and desire to secure by Letters Patent—

The combination of the swinging knife B, box A, pusher F, feed-screw G, and the cam L and pawl mechanism for working the screw, substantially in the manner described.

CALEB R. TURNER.

Witnesses:

FRANK BLOCKLEY,
JAMES H. HUNTER.