

W. C. CHILDS.
Grate-Bar.

No. 168,615.

Patented Oct. 11, 1875.

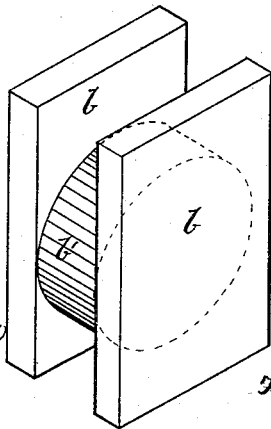
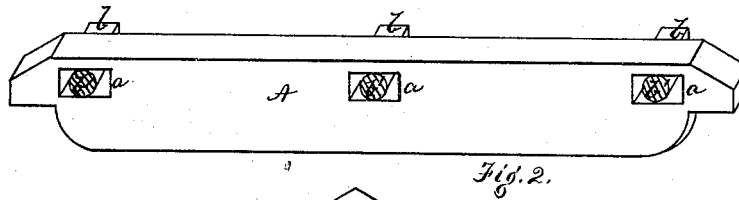
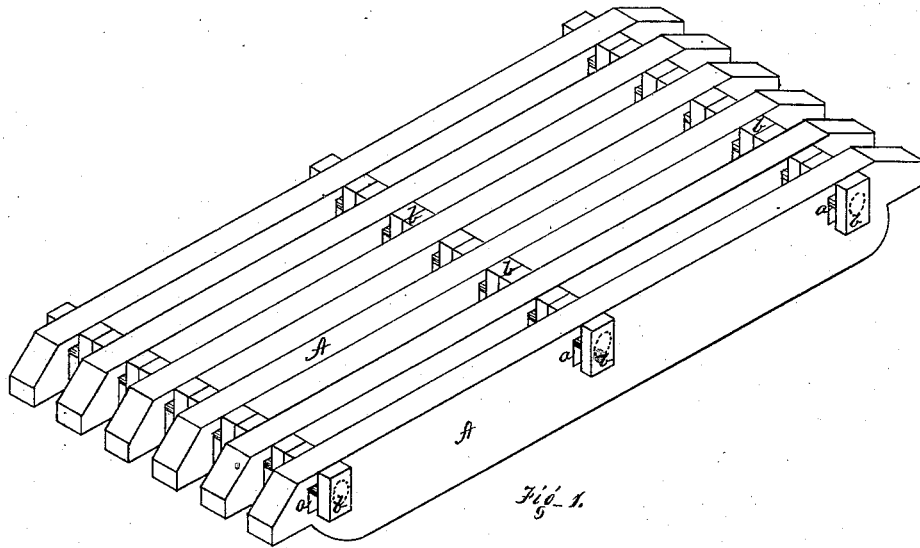

WITNESSES.

R. C. Newhall

S. C. Fidler.

INVENTOR.

Walter C. Childs

By Bakewell & Kerr
Attys

UNITED STATES PATENT OFFICE

WALTER C. CHILDS, OF PITTSBURG, PENNSYLVANIA.

IMPROVEMENT IN GRATE-BARS.

Specification forming part of Letters Patent No. 168,615, dated October 11, 1875; application filed August 23, 1875.

CASE A.

To all whom it may concern:

Be it known that I, WALTER C. CHILDS, of Pittsburg, in the county of Allegheny and State of Pennsylvania, have invented a new and useful Improvement in Grate-Bars; and I do hereby declare the following to be a full, clear, and exact description thereof, reference being had to the accompanying drawing forming a part of this specification, in which—

Figure 1 is a perspective view of a series of grate-bars illustrating my invention. Fig. 2 is a similar view of a single bar, the detachable lugs being broken away. Fig. 3 is a view of one of the detachable lugs.

Like letters refer to like parts wherever they occur.

My invention relates to the construction of grate-bars; and consists, first, in a grate-bar formed from Bessemer steel, and provided with suitable lugs for determining the distance between the bars when arranged to form a grate; second, in a grate-bar having detachable lugs, so that, by changing the lugs, the distance between the bars of a grate may be increased or diminished according to the quality of the fuel.

Grates and grate-bars have heretofore been cast of iron, and, while the superiority of steel for the purposes of a grate-bar has been recognized, no attempt has been made to produce such an article, for the reason that cast-steel grate-bars were too expensive, and Bessemer steel, though sufficiently low-priced for the purpose, yet could not be cast.

Grate-bars when cast singly are formed with lugs or projections, which determine the space between the bars, or when cast in clusters are formed with lugs uniting the bars. I therefore propose to produce a Bessemer-steel grate-bar by rolling a blank of the required form, and subsequently securing the lug or lugs to the bar in any convenient way.

In devising a means of producing a Bessemer-steel grate-bar, I have invented a construction which is equally applicable to cast bars, as will be apparent by reference to the drawing, in which—

A represents a grate-bar, formed with one or more slots, *a*, near the upper edge, to receive the detachable lugs. *b b* are detachable lugs, connected by a cross-piece, *b'*, the thickness of each lug *b* being equal to one-half the distance required between the grate-bars—as, for instance, if the opening desired between the bars is one inch, then each lug (or side of the separating-lugs) would be one-half inch. These connected lugs *b b* are inserted in the bar, then turned and secured by wedging or otherwise. The connected lugs *b b* are made of different sizes, and to be interchangeable upon the same bars, so that a grate can be speedily altered to suit different qualities of fuel.

In making cast-metal grates the slots are formed at the time of casting. In making Bessemer-steel bar, the ingot is first rolled into bars of the proper cross-section, and then cut into suitable lengths, after which a number of slots corresponding to the number of lugs desired, are worked in the blank, and the lugs *b b* secured in the manner specified.

The advantages of my Bessemer-steel bar are, lightness, durability, and strength. A bar of one-half the diameter of the usual cast-iron bar will support greater weight, wear longer, and give better draft-space between the bars; and the detachable and interchangeable lugs permit of the space between the bars being increased or decreased at pleasure.

I do not herein claim a Bessemer-steel grate-bar; but

Having thus described my invention, what I claim, and desire to secure by Letters Patent, is—

A grate-bar, having independent detachable lugs attached to the same, substantially as set forth.

In testimony whereof I, the said WALTER C. CHILDS, have hereunto set my hand.

WALTER C. CHILDS.

Witnesses:

F. W. RITTER, Jr.,
E. V. MCCANDLESS.