

G. T. FISHER.
Circus-Seats.

No. 168,631.

Patented Oct. 11, 1875.

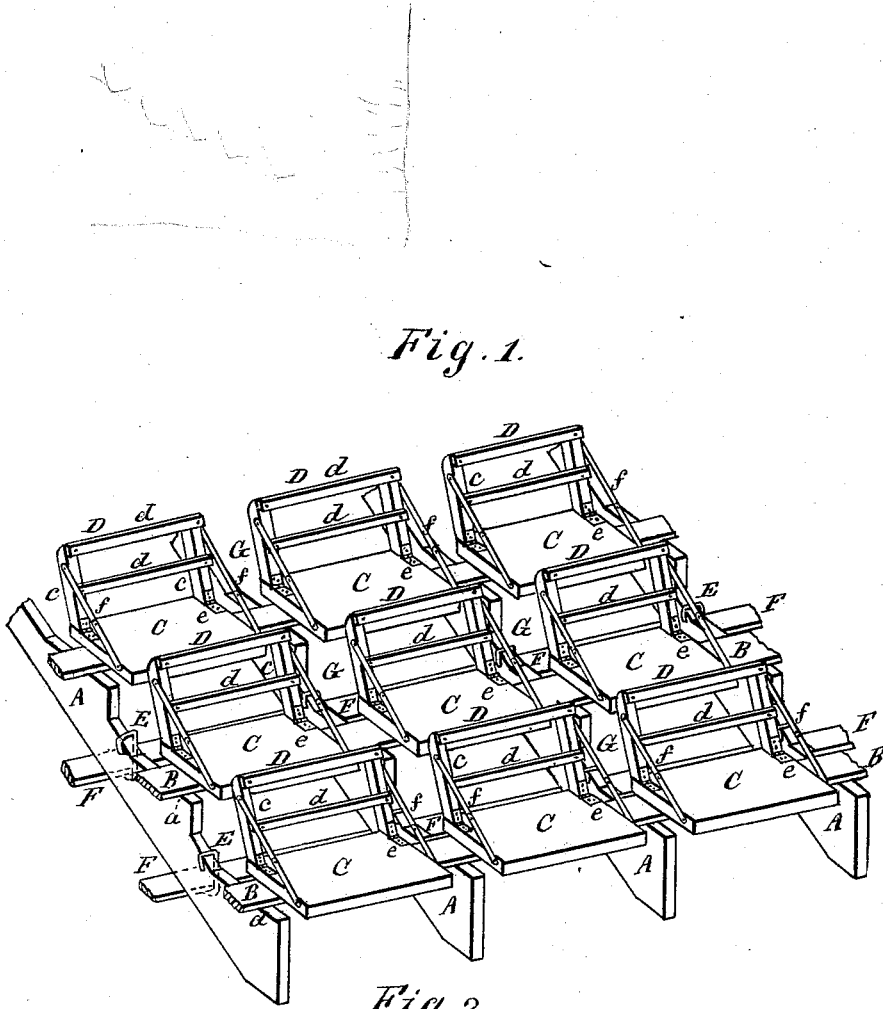

Fig. 1.

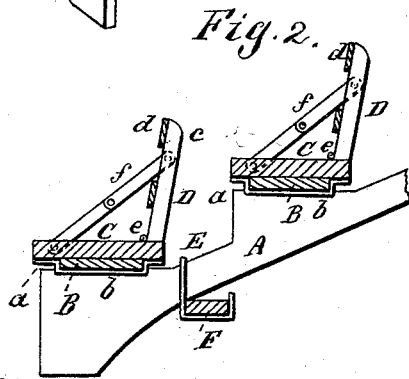

Fig. 2.

Witnesses
Chas Thurman.
R. N. Dyer

Inventor
Geo. T. Fisher
by Geo. W. Dyer
att'y

UNITED STATES PATENT OFFICE.

GEORGE T. FISHER, OF CINCINNATI, OHIO.

IMPROVEMENT IN CIRCUS-SEATS.

Specification forming part of Letters Patent No. 168,631, dated October 11, 1875; application filed September 11, 1874.

To all whom it may concern:

Be it known that I, GEORGE T. FISHER, of Cincinnati, in the county of Hamilton and State of Ohio, have invented a new Improvement in Circus-Seats; and I do hereby declare that the following is a full and exact description of the same, reference being had to the accompanying drawings, and to the letters of reference marked thereon.

The object I have in view is the construction of a simple, easily adjustable, and portable seat especially adapted and intended for exhibitions displayed in tents, which seat increases materially the comfort of the users, which can be constructed without material increase of expense over the ordinary temporary seat, and can be packed conveniently for transportation; and my invention therein consists in the combination of a series of chairs provided with folding backs and loops upon their bottom faces, and resting upon planks which run through said loops and rest upon the steps of uprights or jacks; and further, in combination with said chairs and uprights, a series of adjustable and removable foot-rests, which rest in stirrups pendent from said uprights, as is more fully hereinafter described.

To enable those skilled in the art to make and use my invention, I proceed to describe the same in connection with the drawings.

In the drawings, A A represent the ordinary jack or upright used for temporary seats for exhibitions, provided with steps *aa*. Upon the steps rest planks B, which sustain the chair proper C, said chairs being retained in position by loops *b*, through which the planks B are passed before the seat is put up. To the rear of each chair is secured a folding back, D, which is composed of uprights *c* and horizontal cross-pieces *d*, the said uprights being hinged onto the chair by hinges *e*, and being further connected with chair C by jointed props *f*, which extend diagonally from the uprights to the sides of the seats, and, being jointed in the middle, allow the back D to fold down upon the seat. Below each seat stirrups

E hook onto the uprights in the same plane, and planks or joists F are passed through them, so as to give a foot-rest for those who occupy the seats. These stirrups have hooks at each end, arranged at right angles, so that the hooks which hold the plank shall point in the proper direction when the other hook seizes the upright.

The operation of putting my seats together is as follows: A plank, B, of the usual length of the ordinary planks used for circus-seats is passed through the loops of two of the seats C, said seats together being shorter than the plank upon which they rest. A space, G, is therefore left between each chair, usually about one foot eight inches wide, the length of the planks B being usually twelve feet, and the length of the chairs four feet eight inches. The object of this space is to allow a passage-way between the chairs, and thus avoid the crowding that is inseparable from circuses with the old kind of seats. This passage-way will be in the wake of the uprights; moreover, the foot-rests *f* serve the principal purpose of passage-ways to the seats.

It will be seen that instead of walking over the people on the seats, these planks afford convenient and safe passages to any part of the gallery.

Having thus described my invention, and explained some of its advantages, what I claim as new, and desire to secure by Letters Patent, is—

1. In combination with the uprights A the movable stirrups E, adapted to receive a plank foot-rest, substantially as described and shown.

2. In combination, the chair C, the uprights A, the planks B, the movable stirrups E, and the foot-rest F, all constructed and arranged substantially as described and shown.

This specification signed and witnessed this 11th day of September, 1874.

GEORGE T. FISHER.

Witnesses:

CHAS. THURMAN,
R. N. DYER.