

W. W. WHITE.
Key-Fastener.

No. 168,693.

Patented Oct. 11, 1875.

Fig. 1

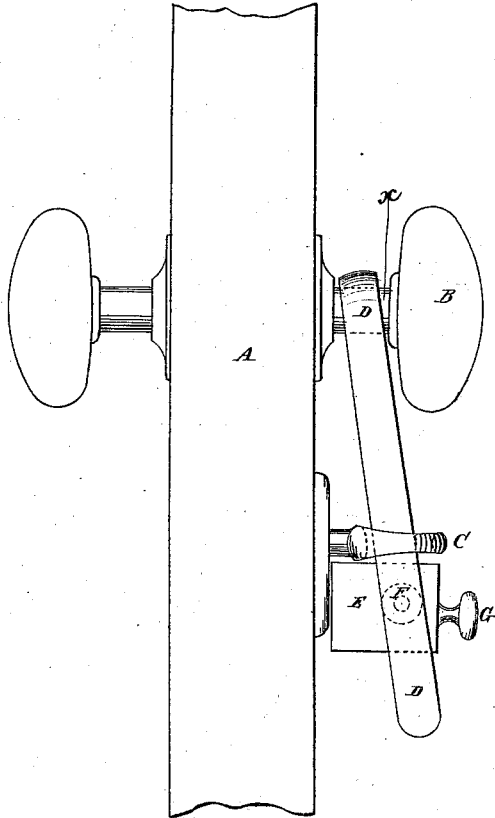
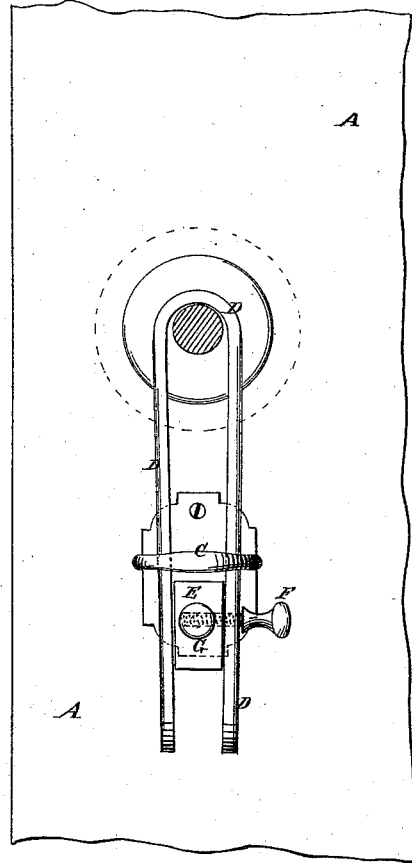

Fig. 2



WITNESSES:

A. W. Almqvist
Chutquik

INVENTOR:

W. W. White

BY

Munnell

ATTORNEYS.

UNITED STATES PATENT OFFICE

WILLIAM W. WHITE, OF NEW YORK, N. Y.

IMPROVEMENT IN KEY-FASTENERS.

Specification forming part of Letters Patent No. **168,693**, dated October 11, 1875; application filed March 28, 1874.

To all whom it may concern:

Be it known that I, WILLIAM WARREN WHITE, of the city, county, and State of New York, have invented a new and useful Improvement in Door-Key Fastener, of which the following is a specification:

Figure 1 is a side view of my improved fastener, shown as applied to a door-key and knob, and Fig. 2 is a front view of the same, the knob-spindle being sectioned at the point *x*, Fig. 1.

Similar letters of reference indicate corresponding parts.

My invention has for its object to furnish an improved device for fastening a door-key by its handle, so that it cannot be turned by burglars or others from the outside of the door, and which, while being effective, shall be simple in construction, easily applied, small and light, so that it can be readily carried in a traveling-bag, or even in a pocket.

The invention will first be fully described, and then pointed out in the claim.

A represents a door, B a door-knob, and C the key, about the construction of which parts there is nothing new. D is a bow or U-shaped bar, which may be made of metal, wood, or other suitable material. The bow B must be of such a length that, when passed around the shank of a door-knob, B, its ends may pass through the handle of the key C, as shown in Figs. 1 and 2. E is a block, which may be made of wood or other suitable material, which is interposed between the arms

of the bar D below the key C, where it is secured in place by a set-screw, F, which passes through one of the arms of the bow D and screws into the block E. The block may also be provided with a knob, G, for convenience in handling it. If desired, the block E may be made larger and with holes formed through it to receive the arms of the bow D. In this case the screw F passes in through the side of the block E, and rests against the side of one of the arms of the said bow D. The block E is designed to prevent the arms of the bow D from being pressed together by turning the key, which might allow the key to be turned far enough to raise the tumblers, so that the bolt of the lock could be forced back with some suitable instrument; but with the block the key is held in such a position that its guards may cover the tumblers and prevent them and the bolt from being reached with any instrument.

Having thus described my invention, I claim as new and desire to secure by Letters Patent—

The combination, with a bow, D, hanging from the knob-shaft and passing through the key-loop, of the block E, receiving the arms of bow on each side thereof, and provided with a set-screw, F, as and for the purpose specified.

WILLIAM WARREN WHITE.

Witnesses:

JAMES T. GRAHAM,
T. B. MOSHER.