

N. CHAPMAN.

Machine for Setting Temple-Teeth.

No. 168,719.

Patented Oct. 11, 1875.

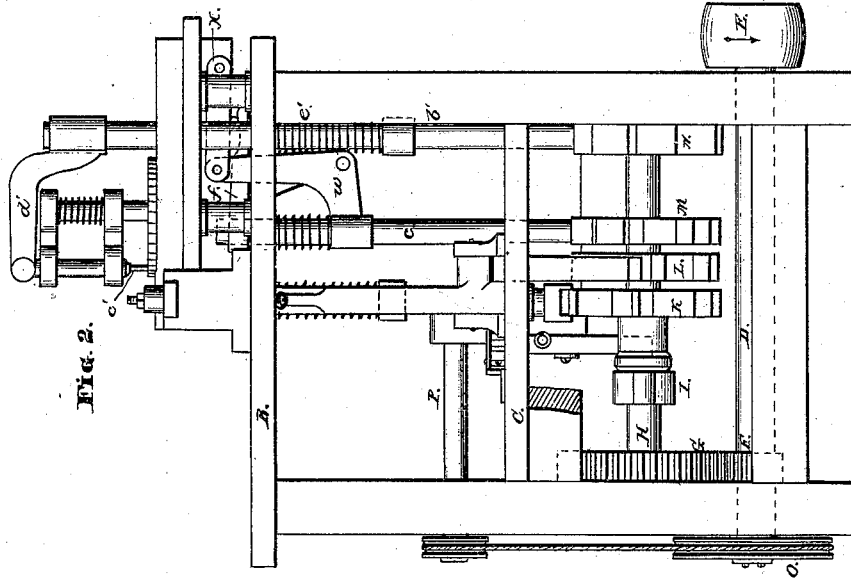

FIG. 2.

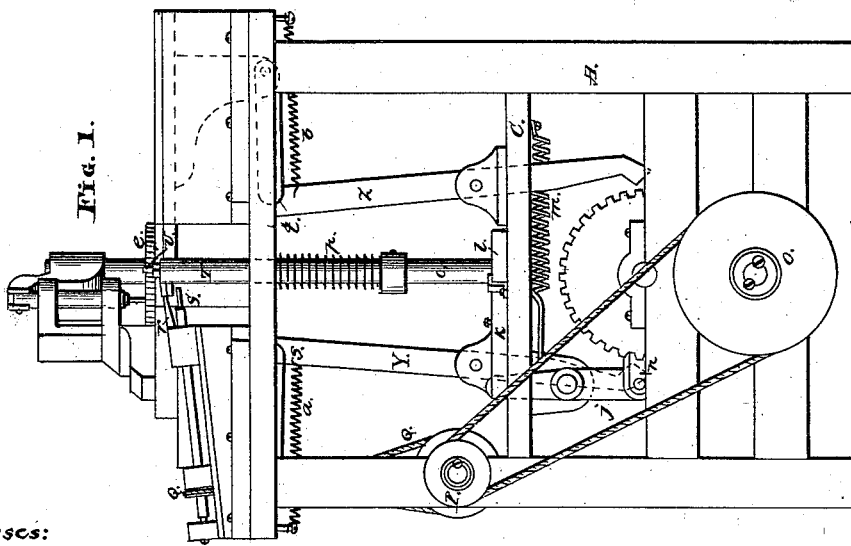

FIG. 1.

Witnesses:
Scott Graham.
J. B. Quisenberry

Inventor:

Nathan Chapman
 By *Daniel Breed*
 Atty.

N. CHAPMAN.

Machine for Setting Temple-Teeth.

No. 168,719.

Patented Oct. 11, 1875.

FIG. 3.

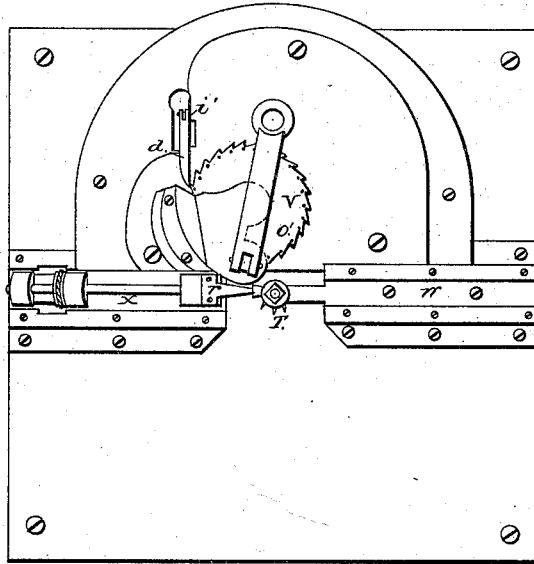

FIG. 5.



FIG. 4.

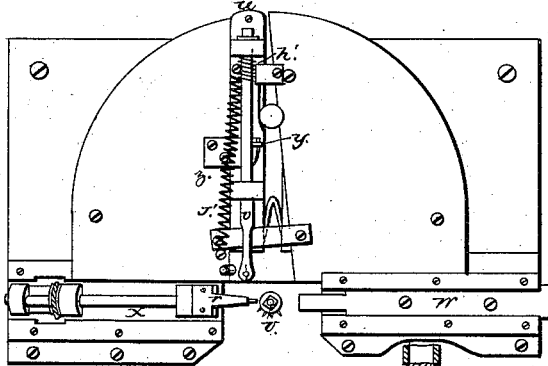

FIG. 6.

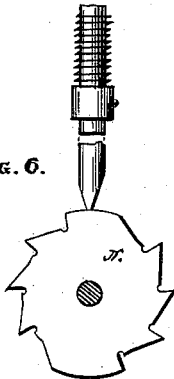

FIG. 9.

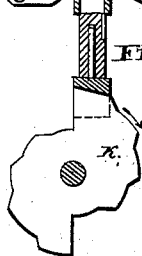

FIG. 10.

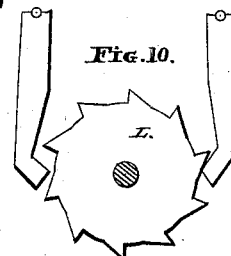

FIG. 7.

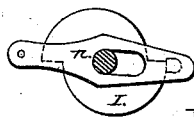
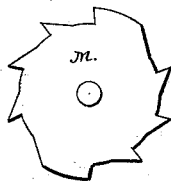

FIG. 8.



Witnesses.
Nathan Chapman
Daniel Breed

Inventor:

Nathan Chapman
By *Daniel Breed*
Atty.

UNITED STATES PATENT OFFICE

NATHAN CHAPMAN, OF HOPEDALE, MASSACHUSETTS.

IMPROVEMENT IN MACHINES FOR SETTING TEMPLE-TEETH.

Specification forming part of Letters Patent No. **168,719**, dated October 11, 1875; application filed September 9, 1875.

To all whom it may concern:

Be it known that I, NATHAN CHAPMAN, of Hopedale, in the county of Worcester and State of Massachusetts, have invented certain new and useful Improvements in Machines for Setting Teeth in Rollers for Loom-Temples; and I do hereby declare that the following is a full, clear, and exact description thereof, which will enable others skilled in the art to which it appertains to make and use the same, reference being had to the accompanying drawing, and to the letters of reference marked thereon, which form a part of this specification.

My invention consists of a flexible automatic forceps for receiving the temple-teeth and carrying them forward into a proper position to be inserted by an automatic punch, and also in a drill and many other devices, all operated in the same machine, and which will be fully understood by the following description.

In the accompanying drawings, Figure 1, Sheet 1, is a front view of my machine. Fig. 2 is a side view of the same. Fig. 3, Sheet 2, is a top view. Fig. 4, Sheet 2, is a bird's-eye view, with the top plate and some other parts removed in order to show the working parts. Fig. 5, Sheet 2, is a view of a roller with the teeth all set in place. Figs. 6, 7, 8, 9, and 10, Sheet 2, are detached views of the cams and other devices.

In the construction of my machine the frame may be of any suitable form; but I prefer to make it as seen in Figs. 1 and 2 at A. This frame is crowned by a table, B, and provided with a platform, C, both of which serve for attaching and supporting the machinery. On the lower part of this frame is a horizontal shaft, D, having a band-pulley, E, for supplying power, and also a pinion, F, which gears into the cog-wheel G, thus transmitting motion to the shaft H and the series of cams thereon, as will be best seen in Fig. 2 at I, K, L, M, and N, the action of which will be hereafter separately explained. This shaft D also carries a band-wheel, O, which gives motion to the shaft P, and, by means of a second band, Q, operates the drill S, for boring holes in the roller T, for inserting the teeth, as will be soon described.

The action of the five cams above mentioned

may be understood from the following brief description: The first cam I, Figs. 7 and 2, is intended to give a partial revolution to the blank roller T at regular intervals after a tooth is set. This cam operates, in connection with a slotted arm, *n*, Figs. 7 and 1, a lever, *j*, a spring, *m*, pawl *k*, and ratchet-wheel *l*, to turn the sliding lifter O, Fig. 1. This ratchet-wheel *l* has an interior pin working in a slot in the sliding lifter O, so that the latter may rise and fall independently of the wheel. The second cam K, Figs. 9 and 2, raises the slide or lifter O and roller T at the proper time, while the coiled spring *p* pushes them down again when released by the rotation of the cam. The third cam L, Figs. 10 and 2, pushes forward the two slides W and X, Fig. 4. This cam acts in connection with the two levers Y and Z, and the links *s* and *t*, attached to the slides, which are drawn back by the coiled springs *a* and *b* when released by the cam. One of these slides is horizontal, and the other is set obliquely, in order to give the proper pitch to the drill S in making the hole for the tooth. As the drill works in making the hole the slide W holds the roller T in place, and prevents it from springing off from the drill. The fourth cam M, Figs. 2 and 8, moves back the slide *c*, elbow-lever *w*, and slide *u*, Fig. 4, which carries the forceps *v*. This cam acts upon this slide by means of another slide, *c*, elbow-lever *w*, and the connecting-rod *x*. A coiled spring, *J'*, Fig. 4, serves to pull the slide *u* and forceps forward when released by the cam M. This forceps *v* is flexible, and has a round hole between the closed jaws. This hole is a little smaller than the wire of which the tooth is made, so as to grasp and firmly hold the tooth. The shank of the forceps has a small pin, *y*, Fig. 4, which works against a cam, *z*, and thus gives the forceps a quarter-turn as it moves back; and the opposing coiled spring *h'*, Fig. 4, gives the forceps a reverse quarter-turn in its forward motion. This same cam M also gives motion to the feed-wheel V by means of a lifting-arm, *f*, on the top of slide *c*, which arm moves the elbow-lever *v'* and pawl *d*, thus turning the feed-wheel V through a fraction of a revolution, or the distance between two feed-holes, *o'*, in the circumference of the wheel. The fifth cam M raises the slide *b'*, with its

arm d' , and thus raises the punch c' , and holds it clear of the feed-wheel V until the proper time to charge the forceps v , when the action of the coiled spring e' brings down the slide or lifter b' and the punch c' , which thus pushes a tooth from the feed-wheel V into the forceps.

The operation of my invention is as follows: A blank roller, T, being placed on the spindle U, supported on the slide o , Fig. 1, and the holes o' in the feed-wheel being supplied with blank teeth ready for insertion, the machine may be set in motion. The drill S makes a hole in the roller T, the slide X slowly advancing to the work by the action of the cam M, as above explained. The oblique position of the drill gives the proper pitch to the hole. At the same time the slide W comes forward to hold the roller T, and prevent it from swinging off from the drill. At the next step the forceps v comes forward, bringing a tooth, and also making a quarter-turn, as above explained, and thus presenting a tooth in front of the hole in the roller, and also in position for the point of the punch r to enter the jaws of the forceps, and push the tooth into the roller while the forceps is opened by the advance of the punch. Now, the forceps returns with a reverse quarter-turn to receive the next tooth from the feed-wheel V. As the work progresses the roller T is moved a partial revolution by the cam I and other devices, as above explained, and thus the teeth are set spirally around the roller, one series of teeth extending one-half the circumference of the roller, as seen in Fig. 5.

Having thus described my invention, I claim—

1. The forceps v , for receiving the teeth and carrying them forward for insertion into the roller T, substantially as set forth.
2. The drill S and punch r , mounted upon the slide X, and operating substantially in the manner and for the purposes set forth.
3. The arrangement of the feed-wheel V, the forceps v , and punch r , for operating in combination, and automatically setting teeth, substantially as set forth.
4. The intermittingly-reciprocating slide W, for holding the roller T, substantially as and for the purpose specified.
5. The cam M, slide c , elbow-lever w , link x , and slide u , all arranged for moving the forceps, substantially as set forth.
6. The cam z and pin y , for giving a quarter-turn to the forceps, substantially as set forth.
7. The cam N, slide b' , arm d' , and punch c' , for pushing the teeth into the forceps, as described.
8. The cam K, slide O, ratchet-wheel l , and pawl k , for moving the roller T as the teeth are inserted, substantially as set forth.

In testimony that I claim the foregoing as my own I affix my signature in presence of two witnesses.

NATHAN CHAPMAN.

Witnesses:

LEANDER HOLBROOK,
LEANDER HOLBROOK, Jr.