

J. W. H. DOUBLER.  
Equalizer of Spring Power.

No. 168,729.

Patented Oct. 11, 1875.

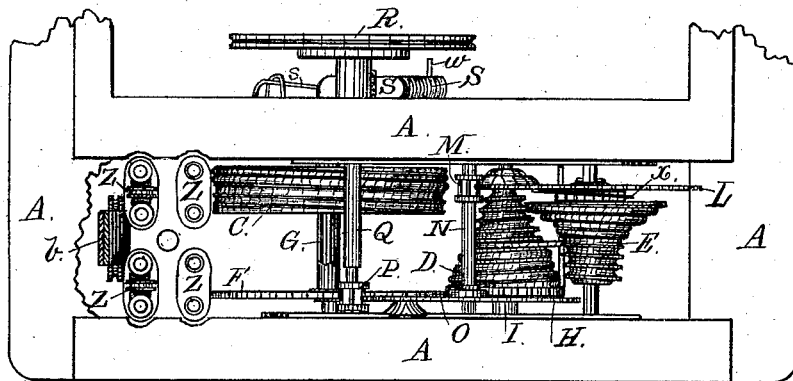
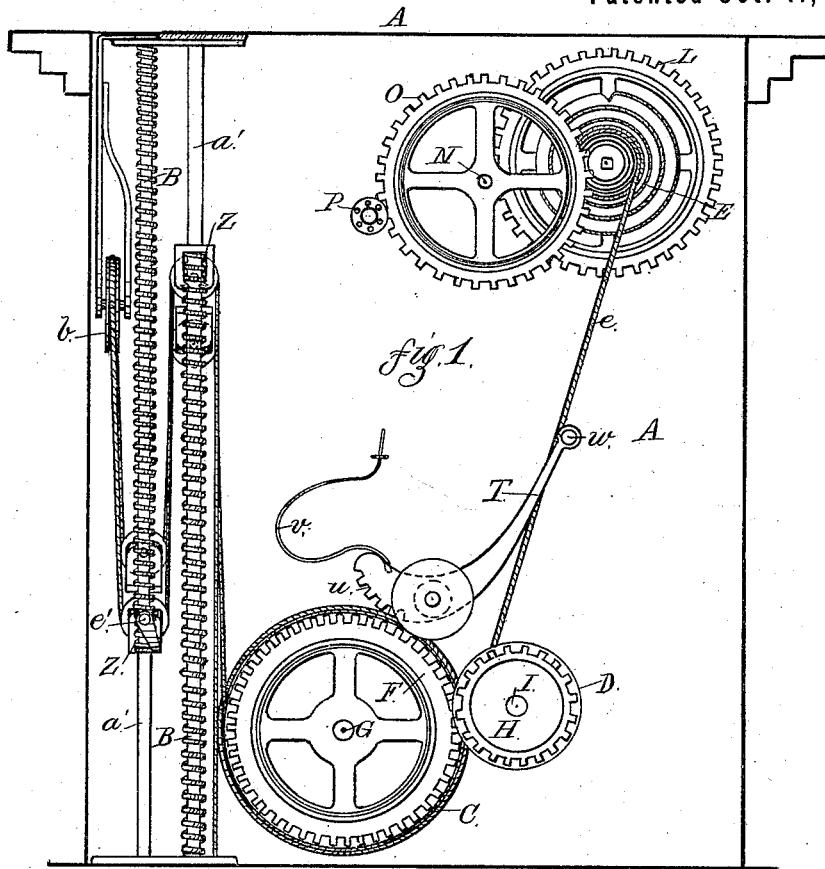

Witnesses.  
George T. Smallwood Jr  
John Robey Jr.

Fig. 2.

Inventor.  
John W. H. Doubler  
By John J. Macsted  
his Atty.

J. W. H. DOUBLER.  
Equalizer of Spring Power.

No. 168,729.

Patented Oct. 11, 1875.

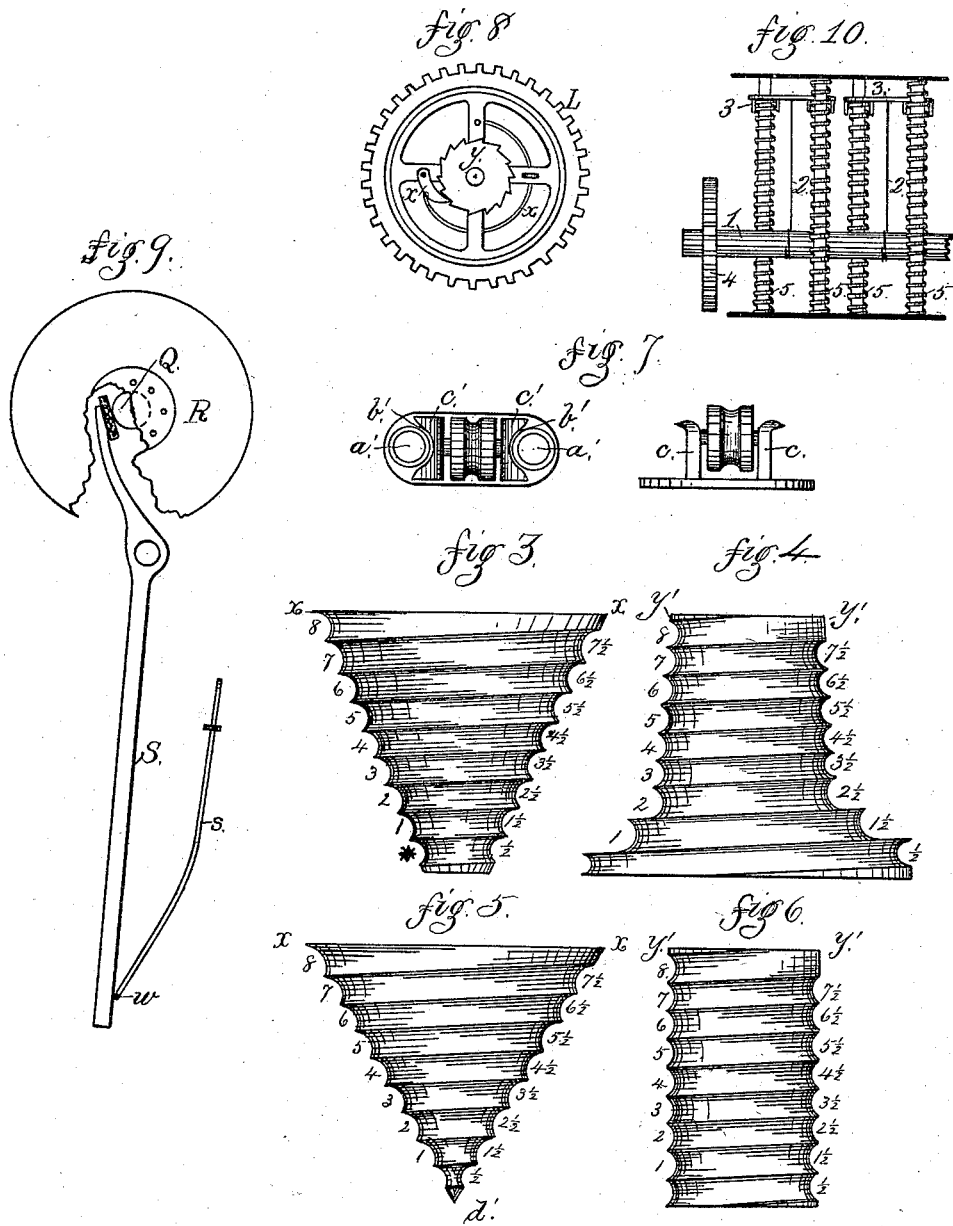

Witnesses:  
 George T. Smallwood Jr.  
 John Robert Jr.

Inventor:  
 John W. H. Doubler.  
 By John J. Halsted  
 his Atty.

# UNITED STATES PATENT OFFICE,

JOHN W. H. DOUBLER, OF PHILADELPHIA, PENNSYLVANIA, ASSIGNOR OF  
ONE-HALF HIS RIGHT TO GEORGE F. GODLEY, OF SAME PLACE.

## IMPROVEMENT IN EQUALIZERS OF SPRING-POWER.

Specification forming part of Letters Patent No. **168,729**, dated October 11, 1875; application filed  
September 27, 1875.

*To all whom it may concern:*

Be it known that I, JOHN W. H. DOUBLER, of the city and county of Philadelphia and State of Pennsylvania, have invented an Improved Equalizer of Spring-Power; and I do hereby declare that the following, taken in connection with the drawings which accompany and form part of this specification, is a description of my invention sufficient to enable those skilled in the art to practice it.

My present invention is an improvement on that described in my application for patent for a "mechanical motor," and which was allowed September 10, 1875; and it has for its main object an equal and uniform running motion of the mechanism driven by the spring-power from the commencement to the close of its action.

To this end my invention consists in a novel construction of the winding-drum employed, in connection with a novel construction of fusee; in an improved and more compact arrangement of the springs and of their cord and pulleys, whereby the number of springs may be increased and made more efficient, and the power or duration of power increased without the necessity of enlarging the frame or case; in combining with the mechanism a lock-bar to engage with and lock the gear in case the cord breaks; in a peculiar construction of the pulley frames or slides, whereby they shall, while running, preserve their proper level positions, and not be liable to tilt to an angling position, and so bind and cause friction; and in other details hereinafter stated.

Premising that my invention is designed for use in driving sewing-machines, power-presses, churns, lathes, jig-saws, street-cars, &c., and, in fact, wherever a motor is wanted, I will now proceed to describe its construction.

Figure 1 of the drawings represents, in elevation, a back view of a case or box containing my improvements, the back of the case being removed the better to display the mechanism. Fig. 2 is a plan view, the top of the case and the top plate which supports the rods for the coiled springs being removed; Fig. 3, the fusee; Fig. 4, the winding-drum; Figs. 5 and 6, diagrams serving to illustrate, by way of comparison and contrast, the prin-

ciples upon which the fusee and the drum, shown respectively in Figs. 3 and 4, are constructed, in order to produce an equalization of the spring-power; Fig. 7, a plan and a side view of one of my improved slides and its pulley. Fig. 8, the spring-pawl and ratchet on the winding-drum shaft; and Fig. 9, lever-brake or stop-motion; Fig. 10, a modified arrangement of the slides and cords.

A represents a frame or case to receive or support the mechanism; B, the several series of pairs of coiled springs arranged in parallel rows side by side across the case, and not in continuous line lengthwise of the case, as in my former invention above named. This arrangement enables me within the same allotted space to employ more springs, and to double and treble, &c., their number, if desired, by adding a little to the width of the case without increasing its length, the cord for the springs being by means of a pulley, *b*, guided crosswise of the case to lead it from one cross-row or series of springs to another, and so on, for any number or rows desired. C is the barrel on which the cord *c* from the springs is wound when winding up the works to compress the series of springs and store up the power; D, the cone fusee; E, the winding-drum, whose cord *e* connects with the fusee; F, a gear on the barrel-shaft G, and which engages with a gear, H, on the fusee-shaft I, and imparts motion thereto, and thence by the cord *e* to the winding-drum E, this cord having its ends secured respectively to the fusee and to the drum.

On the shaft of drum E is a large gear, L, which engages with a pinion, M, on an intermediate shaft, N, the large gear O on which engages with a pinion, P, on the shaft Q, on whose outer end is a wheel, R, from which motion may be imparted by a belt or otherwise directly to the sewing or other machine. S is a spring-lever brake, one end of which bears by force of the spring *s* on the shaft of wheel R for the purpose of arresting the motion of the machine, excepting when released at the will of the operator. T is a locking-lever, having a geared or toothed eccentric, *u*, a spring, *v*, and a lateral arm or pin, *w*, its gear being kept out of engagement with the

teeth of the barrel-gear F, when the apparatus is in operative condition, by reason of the cord *e* bearing upon the arm *w*; but if this cord should break the spring *v* instantly throws its teeth *u* into engagement with F, and locks the mechanism against further movement or running down, thus serving as an effective automatic stop-motion. The winding-drum E is free to revolve on its axis in one direction; but a spring-pawl, *x* *x*, and ratchet *y* prevent its revolution in the other direction. Z are the pulley-slides, provided not only with bearings at their outer ends, and through which the rods *a'*, which support the springs, are passed, but also with other bearings, *b' b'*, at their inner ends, formed by bending outward the tops of the uprights in which the pulleys are journaled, as shown, and making in each of such uprights *c' c'* a concave or half socket to serve as a bearing on the two springs of each set or pair. The slides or plates Z are thus sustained both at top and bottom, and remain under all conditions in their proper and true positions, and any variation in the strength of the two springs forming a pair, or any other cause, cannot under this construction tip or tilt the slide so as to make it bind and create friction on the rods in their ascent or descent; but on the contrary both sides of the plate must move in unison.

I will now describe the cone fusee D and the winding-drum E, and the rule and principle upon which I construct them, referring more particularly to Figs. 3 and 4, and the diagrams, Figs. 5 and 6, the latter serving by way of clearer explanation. Assuming that the springs would require a weight of four hundred pounds to compress them, two hundred pounds would compress them just half the distance, and at that point one-half the power of the springs would have been attained. Now, letting diagram 5 represent a cone-pulley of the same diameter at its base as the cone-pulley D, and with the same length of axis, but tapering to a point, and letting the diagram 6 represent a parallel-sided drum whose diameter is just half that of the base of the cone shown in the diagram 5, and desiring to start at a power of two hundred pounds (or the mean power) at the point *d'*, or apex of the cone, we would commence to wind at point or beginning of the groove of the cone tip, which is the two-hundredth part of the radius of the parallel winding-drum, and, winding upon it from the cone, would find that when we had made two revolutions of the parallel drum the cone would have made four revolutions, or one-half the whole number allotted to it, and the parallel drum both being constructed for eight revolutions corresponding with those marked from 1 to 8 in Figs. 3 and 4, so that the cord would stand in diagram 6 at the second revolution—*i. e.*, at one-fourth of the whole number—and at diagram 5 at the fourth revolution, or one-half of the whole number of allotted revolutions, and at that

point (which is the mean diameter of the cone) the cord will have reached the same diameter on this cone as is equal to the diameter of the parallel drum. Hence the power at these two points on both the cone and drum are now equal to each other. By this we see that, the power starting at the apex or tip, and so on to 1, 2, 3, 4, 5, 6, 7, 8, 9, &c., up to 200, (if desired,) we have only one-fourth of the power or whole capacity of the springs when entirely compressed, the first half performing one-quarter, and the last or strong half performing the three-quarters.

It must be borne in mind that each revolution of the cone fusee, whether made by winding the cord from the small end or from the large end, takes up the same amount of cord from the spring-cord, or compresses the springs an equal distance, as each revolution of the cone fusee turns the barrel on which the cord is wound or taken up from the springs an equal distance according to the length of the cord required to compress the springs, and the number of revolutions desired—for instance, if a series of springs were used requiring the taking up of twelve feet of cord to compress them, and it were desired to take it up by four revolutions, a barrel would be required that would take up three feet at each revolution. And if, now, it were desired to have the cone fusee make eight revolutions, it would be requisite to have a gear on this fusee that would turn the barrel (on which the spring-cord winds) just one-half a revolution; and, in such case, it is apparent that at each revolution of the cone fusee there would be eighteen inches of spring-cord taken up. Not so, however, with regard to the winding-drum, which winds the cord off from the cone fusee; because, as the first turn of the parallel drum takes up considerably more than any other turn, the first and second revolutions of this drum compressing the springs one-half the distance—that is, two being one-quarter the whole number of revolutions required to wind—and so on, each revolution takes less of the spring-cord, the last revolution of the parallel drum would revolve the cone a half revolution, and the fusee would revolve the barrel a quarter revolution only, taking up but nine (9) inches of the cord connected with the springs. But as it is impracticable, if not impossible, to employ a cone fusee tapering to an absolute point or apex, inasmuch as it requires a shaft passing through its axis, its taper end must be enlarged, and this enlargement, of course, changes the circumference throughout, except at the base or largest diameter *x x*, the axis or length remaining, of course, the same, and the smaller end receiving the maximum of this increase, as will be seen by referring to Fig. 3.

I now ascertain the mean diameters of this truncated-cone fusee (see Fig. 3) by adding together the diameters of the large and small ends, and dividing their sum by two, which gives the equalization of this fusee, it being

at that point or power half wound up. At that power the cord would stand at revolution four, (4,) the revolutions 1, 2, 3, and 4 of the fusee being unwound, the cord remaining and to be yet unwound on revolutions 5, 6, 7, and 8 by the remaining six revolutions of the drum E, two revolutions having been used to wind the first four revolutions of the cone fusee. As the fusee is not enlarged at  $x x$  by the enlargement at its smaller end, I retain the same diameter of the winding-drum at its end  $y' y'$ . To ascertain the increase of the length of cord required by the enlargement of the first half of the revolutions, commencing at the starting point \* I measure up to 4. I then enlarge the winding-drum E at its end, so that the first quarter of the whole revolutions will take up the first half of the revolutions of the fusee. The cord would then stand on E at Fig. 2, and on the fusee D at Fig. 4, at which points the two diameters are equal, the drum E tapering thence down to  $y' y'$ , as shown, and I thus produce the same result as in the supposititious case of the parallel drum and the pointed cone fusee above described.

It will be observed that when the springs have expanded and taken up the cord the barrel C and the drum E are unwound, the cord having been taken up by the fusee D, and as we turn the drum E it takes up the cord from the fusee, causing it to revolve, and as the fusee revolves it causes the barrel C to revolve by means of the gear H on the fusee-shaft acting in connection with the gear F on the barrel-shaft, thereby taking up the cord and compressing the springs; and vice versa as the springs expand.

The following rule may be given as a guide for making the fusee and the winding-drum: Make the smaller end of the fusee as small as convenience will allow, as it will then require less enlargement of the drum. Have the taper regular from one end to the other. Have the grooves a regular distance apart, so as to give uniform increase of leverage as we run from the smaller to the larger end, and the fusee is complete.

To make the winding-drum E, I take the radius of the large end of the fusee D as the measure of the diameter of the smaller end of the drum, and, starting at that point, I number to the dividing-line of three-quarters ( $\frac{3}{4}$ ) of the revolutions, and at this last-named line or point I enlarge the diameter up to the mean diameter of the fusee, and this gives a gradual taper, as seen in the figure, from that point back to the starting-point or small end. I next ascertain the length of cord taken up by the first half of the revolutions, commencing at the small end of the fusee, and then commence to enlarge the drum gradually, but more abruptly than the taper from the smaller end, from the three-fourths line or revolution above named, making this enlargement such in size that the remaining one-fourth of the required revolutions shall take up a length of

cord equal to the first half of the revolutions of the fusee D, this enlarged end of drum E acting in conjunction with the small end of fusee D, and vice versa when the two are in practical operation. By this rule the drum performs the same number of revolutions as the fusee.

If it be desired to increase the number of revolutions of a drum—say, for instance, to revolve the fusee eight times and the drum sixteen (16) times—I should in that case take one-half the radius of the large end of the fusee for the diameter of the small end of the winding-drum; then take the radius at the mean diameter of the fusee (instead of the diameter itself, as in the previously-described formula) for the enlarged diameter at the line of three-quarters, ( $\frac{3}{4}$ ), numbering from the small end up to revolution twelve, (12,) that being three-quarters of the whole number of revolutions; and then from that point I proceed, as heretofore described, to enlarge the drum gradually, so that its remaining four revolutions (being one-fourth of the whole) shall take up the cord on the fusee to No. 4 of its revolutions—or, in other words, to one-half of its whole number—and this will, as in the other case, give a regular, uniform, or equalized power, but with double the time at the expense of half the power.

It will be evident that the power may be made the strongest at the weak end of the spring, if desired, by enlarging the large end of the winding-drum, so as to wind or take up more cord, and by reducing proportionately the remainder of the drum.

The fusee and drum may be proportioned so as to increase speed at the expense of power, or to increase power at the expense of speed, the same as in other gearing.

For the purpose of indicating when the spring-power is fully wound up, and to prevent overwinding, a pin,  $e'$ , attached to one of the pulley-slides, (see Fig. 1,) is made long enough to project through a vertical slot in the back of the case, any appropriate mark indicating to the eye the point beyond which the pin should not be allowed to rise. This slot it is not necessary to illustrate.

The winding-drum may be shaped so that the power would be strongest at any point desired, at either end, or in the middle, by making its enlarged diameter or diminishing its diameter at such desired point, so as to have a partially equalized power.

Fig. 10 shows a modification in the arrangement of the springs, cords, and slides, the short cords 2 passing down directly from the slides 3 to a common barrel or shaft, 1, the gear on this shaft being represented at 4, and the rows of pairs or sets of springs at 5. By this arrangement a single long cord need not be used, but, instead, a series of shorter ones, one for each pair of springs. I thus obtain the combined power of the whole of the springs, and have a length for each cord equal to what each pair of springs can take up. The aggregate

power of all is thus stored up on one shaft, and I gear up for the required speed from that shaft; or a single slide or plate may be employed to compress all the springs used, and one or more cords extending from such plate to the shaft.

I claim—

1. The winding-drum E, constructed as described, and operating in conjunction with the fusee to equalize spring-power.

2. The combination, with the drum E and fusee D, of the barrel C, for winding the spring-compressing cord.

3. The combination, with a spring-power substantially such as described, of a power-equalizing mechanism, substantially as shown and described.

4. The described compact arrangement of the several series of sets of springs in rows parallel with each other, the spring-compressing cord being guided in one direction across

one row, and in the opposite direction across its next adjacent row.

5. In combination with the gear-wheel F on the barrel-shaft, the eccentrically-gear-ed locking-lever T, adapted to be held out of engagement with the wheel by the fusee-cord, and to spring into such engagement when the cord breaks, substantially as shown and described.

6. The pulley-slides Z, constructed, as described, with curved guide-bearings 2 2, adapted to bear upon the outside of the springs, substantially as shown, and for the purpose set forth.

7. The combination of the fusee D, drum E, barrel C, parallel rows of springs, intermediate gears, and cords *c* and *e*, substantially as and for the purpose set forth.

JOHN W. H. DOUBLER.

Witnesses:

EDWIN F. GLENN,  
THEODORE JORDAN.