

L. GODDU.
Book-Stitching Machine.

No. 168,736.

Patented Oct. 11, 1875.

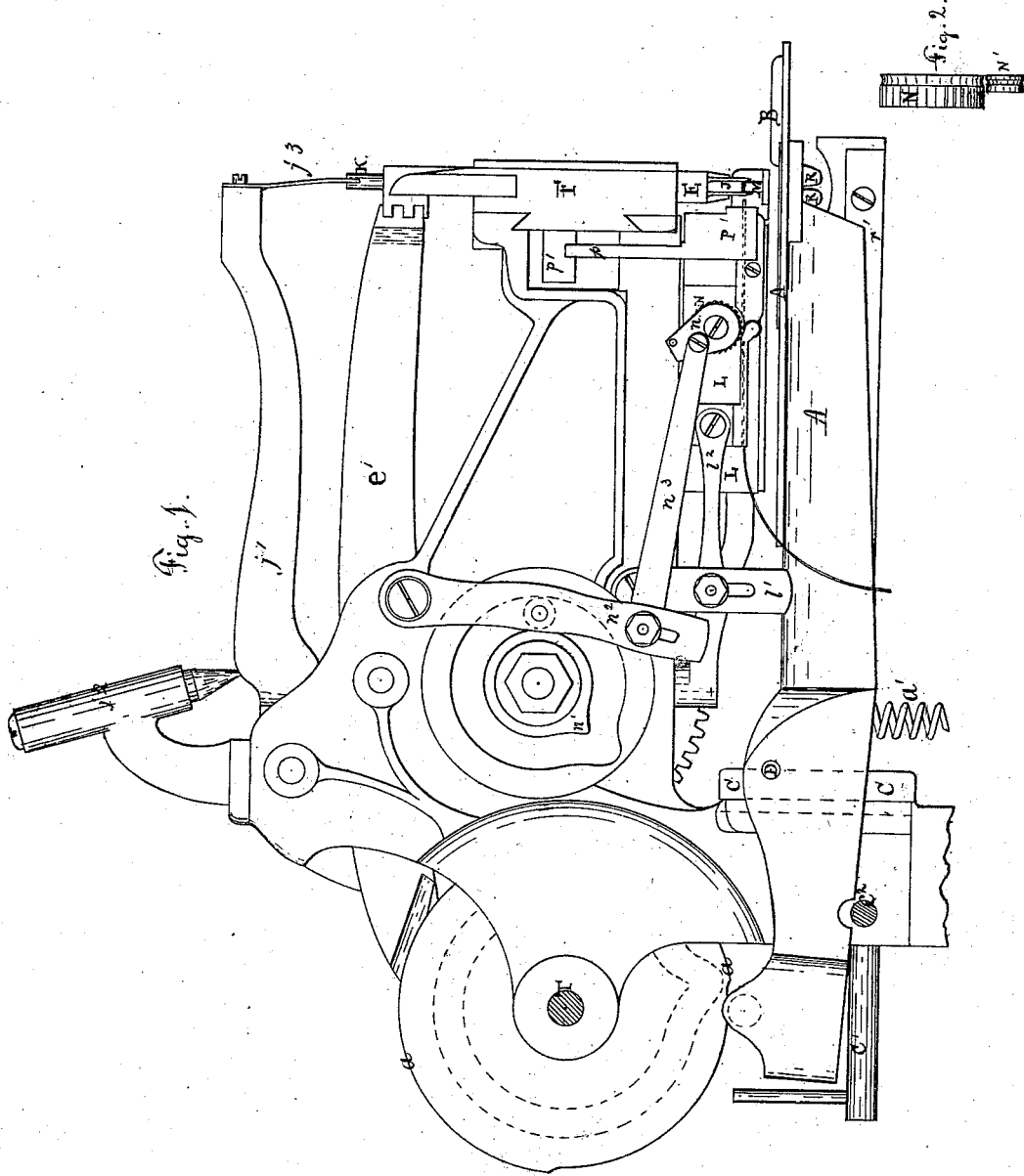

Chas. F. Sleeper.
J. Birn Lord

Louis Goddu
by J. E. Maynard
his atty

L. GODDU.
Book-Stitching Machine.

No. 168,736.

Patented Oct. 11, 1875.

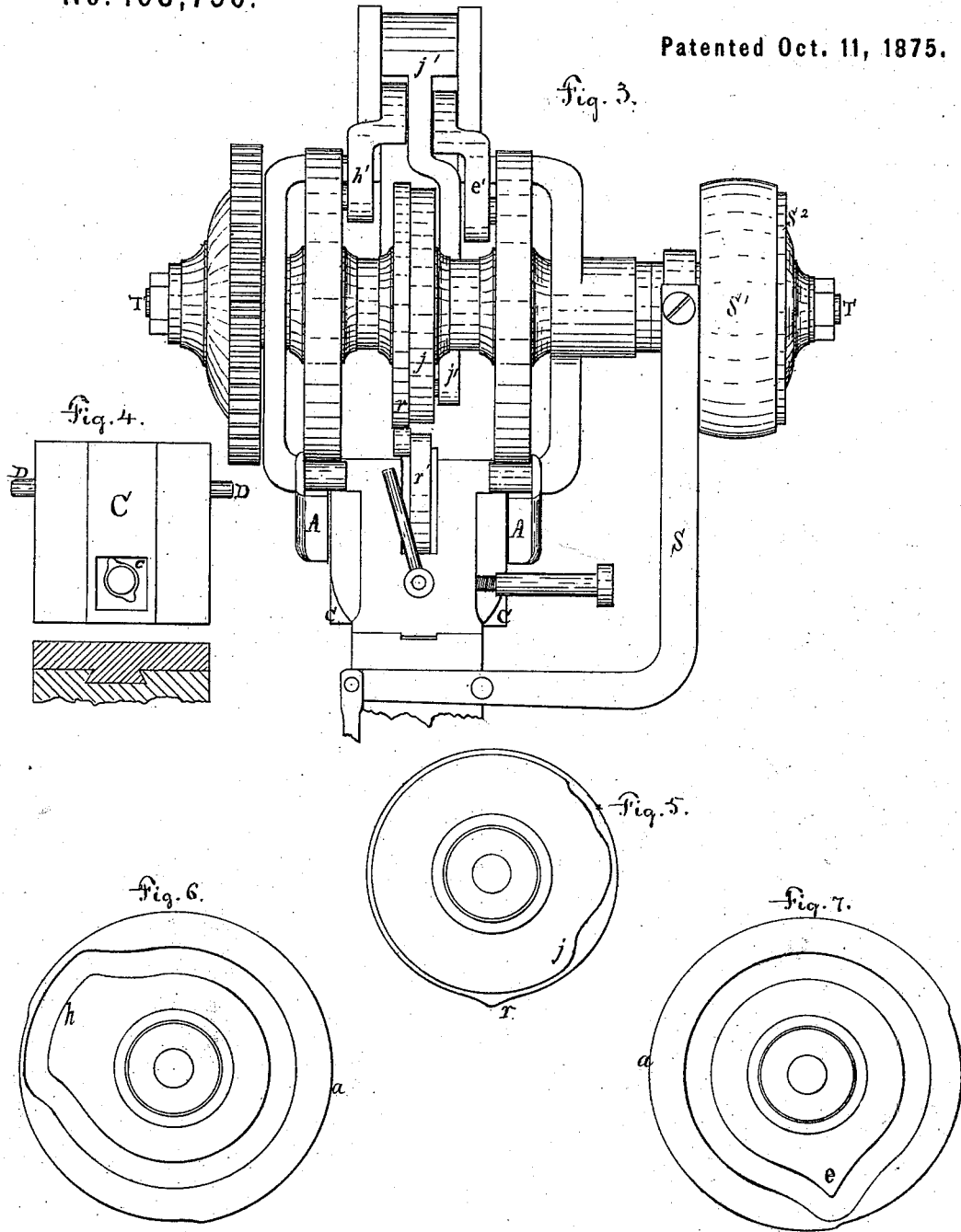

Chas. F. Sleeper.
of Brown & Lord

Louis Goddu
by J. E. Magruder

L. GODDU. Book-Stitching Machine.

No. 168,736.

Patented Oct. 11, 1875.

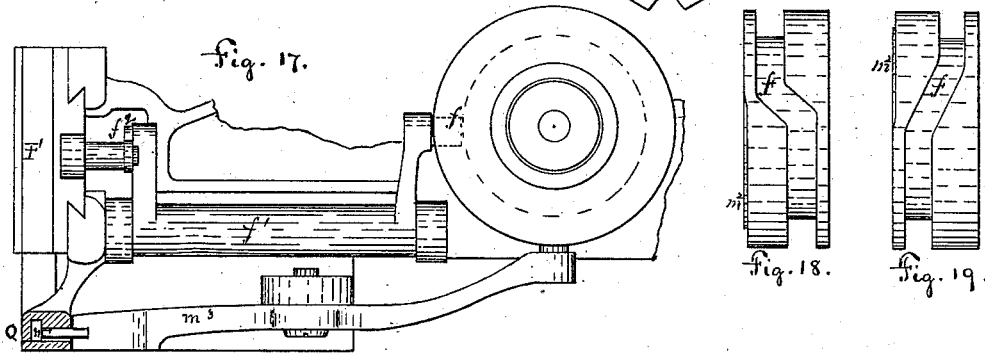
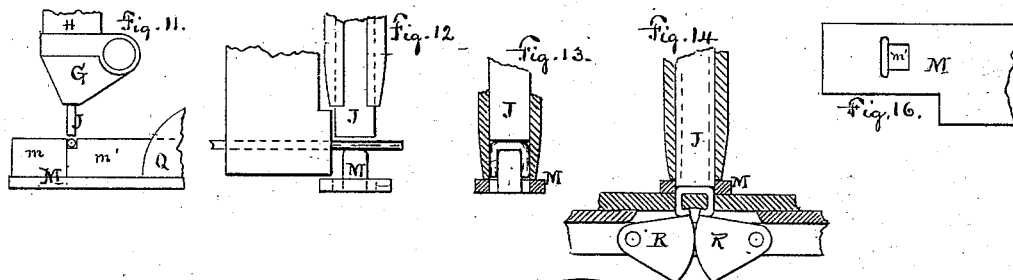
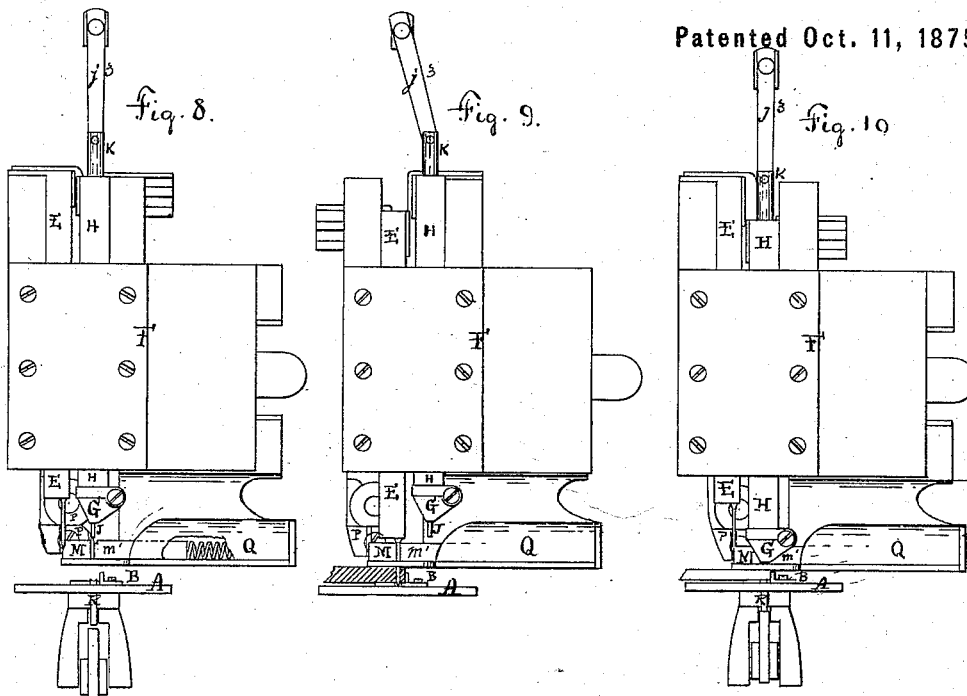

Chas. P. Sleepers.
J. Brown Lord

Louis Goddu
by J. E. Maynard
his atty

UNITED STATES PATENT OFFICE.

LOUIS GODDU, OF WINCHESTER, MASSACHUSETTS, ASSIGNOR, BY MESNE ASSIGNMENT, TO HORACE BARNARD, OF NEW YORK CITY.

IMPROVEMENT IN BOOK-STITCHING MACHINES.

Specification forming part of Letters Patent No. **168,736**, dated October 11, 1875; application filed May 23, 1874.

To all whom it may concern:

Be it known that I, LOUIS GODDU, of Winchester, county of Middlesex and State of Massachusetts, have invented an Improved Book-Stitching Machine, for forming, inserting, and clinching staples, adapted especially for uniting together sheets of paper or other material, of which the following is a specification:

My machine consists of a table to receive the pamphlet or other article in which the staples of wire are to be inserted, a pair of awls to make the holes for the legs of the staples, a feeding, a forming, and a driving mechanism, and a clinching or bending mechanism, by which the ends of the legs of the staple which project beneath the article are clinched after the staple has been inserted; and a machine composed of these elements constitutes the first part of my invention. The other parts of my invention relate to and consist in certain combinations of the several parts of my machine.

In Figure 1 of the drawings, which is a side elevation of my machine, the table to receive the article in which the staples are to be inserted is marked A. This table is provided with a gage, B, in order that the staples may be inserted with regularity, and this gage should be adjustable. This table is attached to a stout slide, C, which is attached by suitable ways to the frame, as shown in detail in Figs. 4 and 5, in order that the distance of the table from the under surface of the overhanging arm may be varied as the thickness of the book or other article varies. This table is also pivoted by the pivots D to the slide C, in order that the book may be compressed, at certain points in the process, between the upper surface of the table and the under surface of the overhanging arm.

The awls are mounted on a stock, E, which reciprocates in the slide F, which is attached to the overhanging arm by suitable ways, as shown in Figs. 1, 8, 9, 10, and 17, in order that the awls may be moved sidewise, after puncturing the book, to allow the former and driver to come over the holes formed by the awls. The former G is also mounted on a stock, H, which reciprocates in the slide F, in

order that it may be brought over the holes made by the awl, and be moved away to allow the awl-stock E to return to position for puncturing other holes. The driver J is mounted on a stock, K, which reciprocates within the former stock H, and, consequently, moves sidewise with the former. The feed-slide L is mounted in ways upon the overhanging arm, and has a motion toward and from the former-bed M, in order that when the wire is fed forward by the feed-wheel N the orifice in the feed-slide through which the wire is fed may abut upon the groove in the former-bed into which the wire is to be fed, and thereby make it certain that the end of wire, as it emerges from the orifice in the feed-slide, shall enter the groove in the former-bed. The severing-knives P P are attached to the feed-slide—one rigidly, the other by a pivot—so that they both move toward and from the former-bed with the feed-slide. The former-bed M, by which, in connection with the former G, the staple is formed from the straight wire, is in two parts, one of which, *m*, forms a portion of the under side of the overhanging arm, while the other, *m'*, is so mounted in a box, Q, which is part of the overhanging arm, that it may receive a slight motion toward and from the part *m*, in order that when in contact the groove across the top of the former-bed, which is partly in *m* and partly in *m'*, may be complete, and that, when the part *m'* is moved away from the part *m*, a free passage shall be left for the staple and the driver J.

The clinchers R R are pivoted in a slot in the bed A, and are vibrated around their pivots in such a manner as not only to bend the projecting part of the legs of the staples, but also to cause their grooved faces to press closely against the under side of the book after the staple has been inserted, and thereby not only to clinch the legs of the staples, but also to embed the extreme ends of the staples in the book. The book is at the same time compressed between the table and the overhanging arm.

The operation is as follows: The wire is passed between the feed-wheels N and N' and into the orifice in the feed-slide until its end

reaches the knives P P. The table A is then set so that its surface is at the proper distance from the under surface of the overhanging arm—that is, far enough to allow the article to be operated upon to be moved freely between the two surfaces, but not so far as to prevent the compression of the article between the two surfaces by the motion of the table A upon the pivots D D. This is done by means of the slide C and the cam c . c^2 is a set-screw, by which the cam-shaft c^1 is prevented from turning, and the slide C thereby held in place after it is set. The motion of the table A on the pivots D D is caused by the cams a . The gage B is then set to the required distance from the slot in the table in which the clinchers R R are pivoted. The edge of the book is held close up to the gage B, and power is applied, by means of the lever S, clutch S¹, and pulley S², to revolve the main shaft T. The cams a cause the table A to move slightly on the pivots D D, and thus compress the pamphlet firmly between the upper surface of the table and the under surface of the overhanging arm. A double-acting cam, e , actuates the lever e^1 , which actuates the awl-stock E, and thus punctures the pamphlet. The points of the awls, after passing through the pamphlet, enter the slot in which the clinchers are pivoted. While the awls are thus moved the feed-ratchet lever n is thrown forward, (by the cam n^1 , acting through the lever n^2 and connecting-rod n^3), carrying its ratchet with it, and immediately afterward the feed-slide L is thrown forward by a cam-groove on the same wheel as the cam-groove n^1 , but on the other side of it, acting through the lever l^1 and connecting-rod l^2 , until its end is close up to the former-bed M, the orifice in the feed-slide and the end of the wire lying in it being thus brought in line with the groove in the former-bed M. During these movements of the ratchet-lever n and the feed-slide L the slide F is moved (by means of the cam f , acting through the rock-shaft f^1 and connecting-rod f^2) far enough sidewise to bring the former G into proper position, and to bring the driver J directly over the groove in the former-bed M. The wire is then fed forward by the motion of the wheel N, caused by the cam n^1 acting through its lever n^2 , connecting-rod n^3 , ratchet-lever n , and the pawl carried by this lever, into the groove in the former-bed M, and the feed-slide drawn back, by means of the cam l , lever l^1 , and connecting-rod l^2 , until the edges of the knives P P are at such a distance from the former-bed M that the wire when cut shall project equally on each side of the former-bed M.

As soon as the feeding forward of the wire is accomplished the driver J is caused to drop far enough to clamp the wire upon the former-bed M and in its groove by means of a slight depression in the periphery of the cam j , which allows the lever j^1 to be moved by the spring j^2 , which thus, through the connecting-rod j^3 , depresses the driver-stock K; and as soon as

the feed-slide L has completed its backward motion, the pivoted knife P is actuated, (by the projection p' on its former-stock H striking the inclined face of the lever p , which carries this knife,) and severs that part of the wire which remains clamped, as above described, between the driver J and the former-die M, and in the groove of the former-die. The wire is thus severed after the former-stock H begins its downward motion, (caused by the cam h acting through the lever h^1), but before the edges of the former reach the wire. The wire is bent into the form of a staple immediately after it is thus served by the continued downward motion of the former G, the legs of the staple lying between the sides of the former G and the sides of the bed M, and in grooves in the sides of the former G, (which grooves also form ways for the driver J,) and thus being brought directly in line with the holes through the base of the bed M, through which the awls pass to puncture the pamphlet, and also directly in line with the holes formed by the awls. The part m^1 of the former-bed M is then moved slightly away from the part m , (by the cam m^2 acting through the lever m^3), and the driver J is thrown down by its spring j^2 , carrying the staple with it, and forcing its legs into the holes made by the awls. The driver J remains depressed until the clinchers R R are swung upward on their pivots, (by the cam r acting through the lever r^1 , whose fulcrum is at D,) thus bending inward the projecting portions of the legs of the staples, and forcing their extreme ends slightly into the under surface of the pamphlet. The former G is then lifted, (by its cam h and lever h^1); the driver is also lifted by its cam j and lever j^1 , and the table A is lowered away from the overhanging arm, (by the spring a' and the shape of the cams a), relieving the pamphlet from compression, so that it can be readily moved into position to receive a second staple, or so that it can be removed and a second pamphlet substituted. After the former G and driver J have been lifted, the slide F is moved sidewise (by its cam f , rock-shaft f^1 , and connecting-rod f^2) until the awls are brought into position again. The part m^1 of the former-bed M is thrown into contact with the part m (by the spring m^4 and the shape of the cam m^2) before the awls descend, in order that the awls may be supported on all sides and close to the paper, as they puncture the paper.

In the feeding mechanism, n^4 is a stiff spring, which sustains the wheel N' at its free end, and by which the wire is forced up against the wheel N, and into the feeding-groove of that wheel.

The length of the staple may be varied by means of the slots in the levers n^2 and l^1 .

It is obvious that the feeding and forming mechanism above described may be used in combination to manufacture staples. These staples might then be fed, by proper mechanism, into a machine made up of the punctur-

ing, driving, and clinching mechanisms above described, and thus two separate machines be used to do the work done by my machine.

It is also obvious that many changes may be made in the means for imparting motion by the acting parts without substantially changing the machine. It is possible, also, to compress the pamphlet on a stationary table; but I prefer to give the motion to the table for this purpose.

The end of the wire, as it leaves the feed-slide, enters directly into the groove in the former-bed. The wire is securely held in this groove by the driver until it is formed into a staple. After it is formed the staple is surrounded on all sides by solid metal until it is driven, and its legs enter the holes in the article to be operated upon as soon as they leave the holes in the upper clamping-plate—the lower part of the former-bed M.

These features are of great importance in my machine, in which the staple is both formed and inserted, as they make it almost impossible for the wire to go wrong.

It is also of very great importance that the article be properly clamped; and in my machine it is so clamped from the beginning to the end. To accomplish this result I have formed one of the clamping-plates so that both the awls and the driver can act through it, both being guided by it to precisely the same point. I have also formed a slot in the other clamping-plate, through which the clinchers act, and into which the points of the awls enter after passing through the pamphlet. By these means the pamphlet is firmly clamped before it is punctured, and kept so clamped until the staples are clinched.

What I claim as my invention is—

1. The combination of the work-supporting table A with the vertically-adjustable slide C by means of the pivots D, as described.

2. The combination of the work-supporting table A, pivoted at D and operated by cams a, with the overhanging arm, substantially as described.

3. The combination of the puncturing-awls, the staple-driver, and the staple-clincher with the clamping-table A and the overhanging arm, substantially as described, for the purpose of compressing the pamphlet between the latter, while the former operate to puncture the material and insert and clinch the staple.

4. The combination of the stock E, carrying a pair of awls for puncturing the material, the stock H, carrying the staple-former G, and the driver J, working within the former G, with the slide F and suitable actuating mechanism, substantially such as described, the whole combination being and operating substantially as specified.

5. The former-bed M, constructed in two parts, m and m^1 , substantially as described.

6. The combination of the former G with the former-bed M, constructed in two parts, m and m^1 , substantially as described.

7. The combination of the driver J, the former G, and the former-bed M, made in two parts, m and m^1 , substantially as described.

8. The combination of the feed-slide L and the former-bed M, in such relation to each other that the wire-channel in the feed-slide abuts upon the wire-channel in the former-bed when the slide is advanced, the two channels thus forming one continuous channel until the end of the wire has entered the channel in the feed-slide, substantially as described.

9. The combination of the feed-slide L, the former-bed M, having a wire-channel across its face and in line with the wire-channel in the feed-slide, and the former G, substantially as described.

10. The clincher R, having a working surface at an angle with the surface of the material, and which moves on an axis toward the surface of the material in order to clinch the staple-leg, as described.

11. The combination of the table A, the clincher-lever r' , and the clinchers R R, so that the acting-surfaces of the clinchers shall be moved axially by the action of the lever toward the plane of the table, as described.

12. The combination of the puncturing-awls, the staple-driver, and the clinchers with the slotted plates formed by the under surface of the overhanging arm and the upper surface of the vibrating table, all arranged together as described, in order that both the awls and the staple-driver must act through the same slot, and the clinchers through the other slot, as set forth.

13. The combination of the puncturing-awls, the staple-driver, and the clinchers with the two slotted supporting-plates, the upper surface of the vibrating table, and the under surface of the overhanging arm, as described, so that the awls shall operate through the slot in one of the supporting-plates, and their protruding points shall enter the slot in the other supporting-plate, and so that the staple drivers and clinchers shall operate, one through the slot in one of the supporting-plates and the other through the slot in the other supporting-plate.

14. The combination of the awls with the moving die m^1 and shoulder M, operating in connection with the slotted guide Q, forming two holes to receive and support the awls as they puncture the paper, as specified.

15. The combination of the feed-slide L, rod l^2 , and lever l^1 with the feed n , rod n^3 , and lever n^2 , substantially as described.

LOUIS GODDU.

Witnesses:

CHAS. F. SLEEPER,
J. E. KNOX.