

# J. R. PERRY. Organ-Coupler.

No. 168,778.

Patented Oct. 11, 1875.

Fig 1

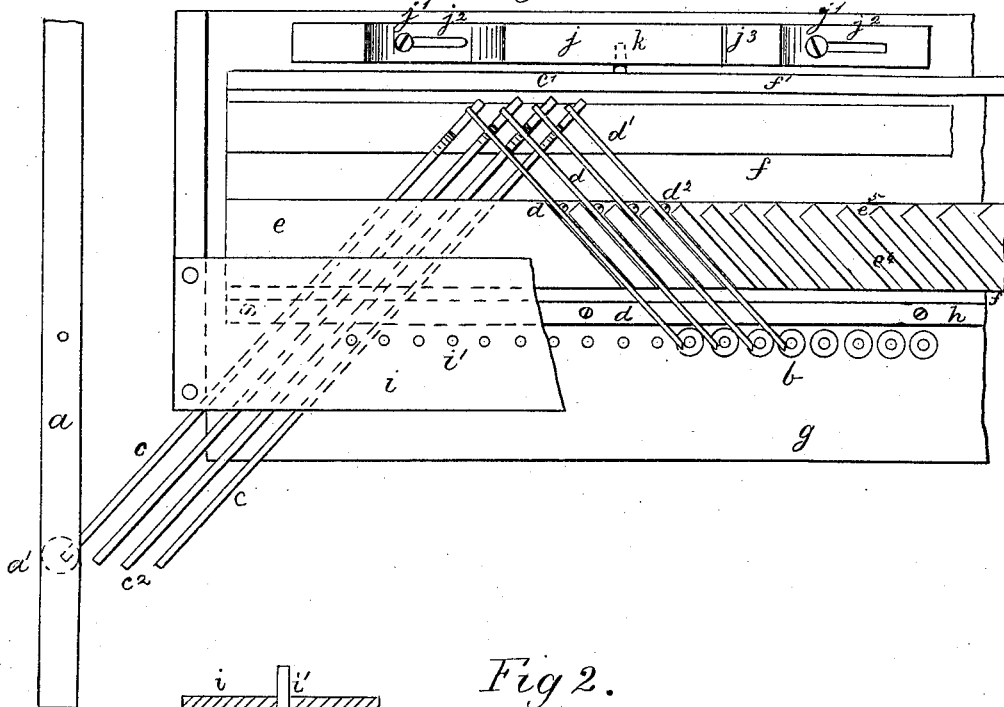

Fig 2.

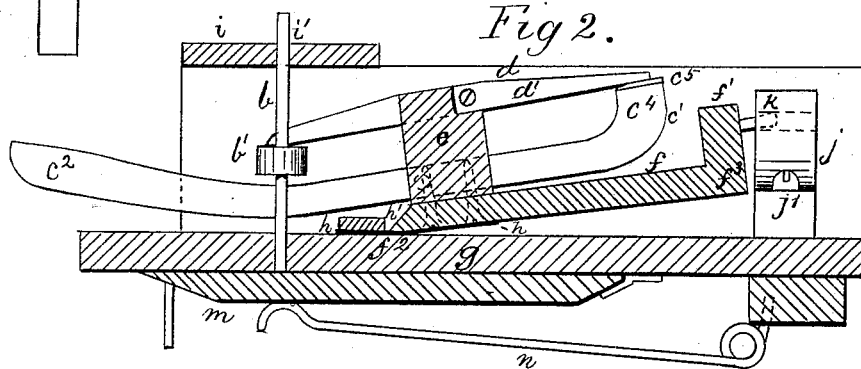
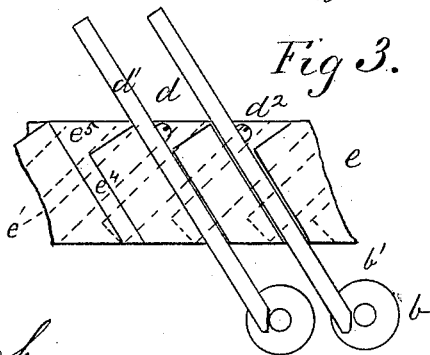

Fig 3.



WITNESSES:

*Wm. Helmich*  
*J. B. Holderby*

INVENTOR.

*Joseph R. Perry*  
per *R. S. A. Lacey*  
ATTORNEY.

# J. R. PERRY. Organ-Coupler.

No. 168,778.

Patented Oct. 11, 1875.

Fig 7.

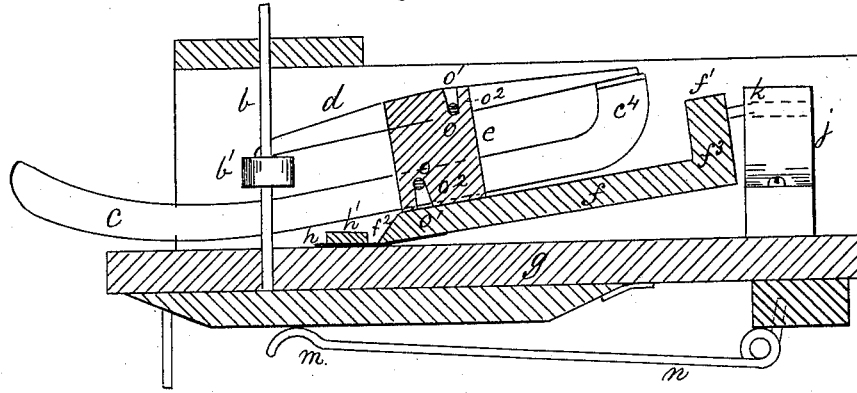

Fig 4.

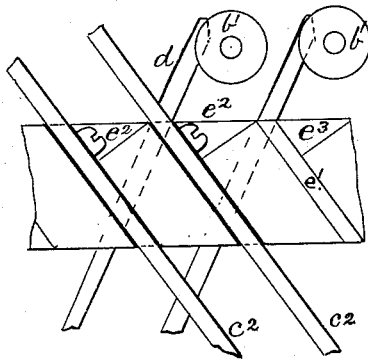

Fig 8

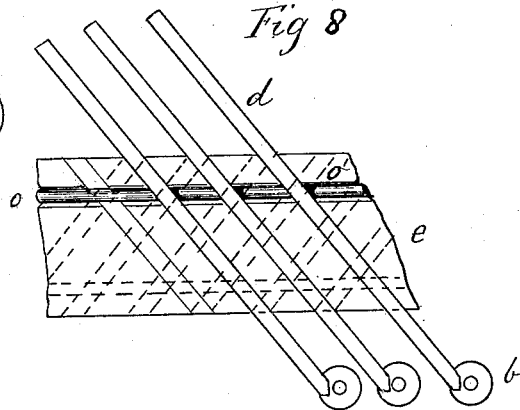
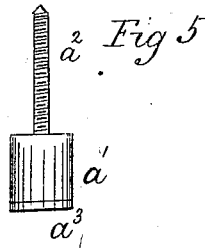
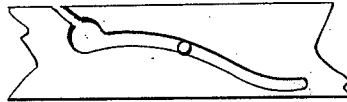

Fig 6



WITNESSES:

*M. Holmquist*  
*J. B. Holdaway*

INVENTOR.

*Joseph R. Perry*  
per *R. S. A. Lacey*  
ATTORNEY.

# UNITED STATES PATENT OFFICE.

JOSEPH R. PERRY, OF WILKESBARRE, PENNSYLVANIA.

## IMPROVEMENT IN ORGAN-COUPLERS.

Specification forming part of Letters Patent No. 168,778, dated October 11, 1875; application filed August 6, 1875.

*To all whom it may concern:*

Be it known that I, JOSEPH R. PERRY, of Wilkesbarre, in the county of Luzerne and State of Pennsylvania, have invented certain new and useful Improvements in Couplings for Reed-Organs; and I do hereby declare that the following is a full, clear, and exact description thereof, which will enable others skilled in the art to which it pertains to make and use the same, reference being had to the accompanying drawing, and to the letters of reference marked thereon, which form a part of this specification.

My invention relates to improvements in what are commonly known in the trade as octa-couplers for organs and other similar keyed instruments, the nature of which will be fully explained by reference to the drawings.

Figure 1 represents a plan view, and Figs. 2 and 7 vertical sections, of parts of an organ with my improvements applied thereto. Figs. 3, 4, 5, 6, and 8 are detail views of parts.

In each of the views similar letters of reference are employed to indicate corresponding parts wherever they occur.

*a* represents a key, of which there is a series of the ordinary construction and arrangement, adapted to operate the pitmen *b* for the purpose of opening the reed-valves, as is well understood by those acquainted with the manufacture of organs and other similarly keyed musical instruments. *c c* are a series of coupler-levers connected with a series of levers, *d d*, that operate the pitmen *b* when desired, and which series of levers *c d* are so arranged and constructed that, when desired, the ends *c'* of the levers *c* can be raised and brought into position, so that the organist, when pressing down any one key so as to produce any one note—say, A—or any series of notes—say, A E F—in any part of the key-board, shall, at the same time and by the one action on the key or keys, cause another note, A, or other notes, A E F, to be sounded in concord with the first note A or notes A E F, but an octave higher or lower, as the case may be, according to whether the notes selected are in the bass or treble part of the key-board. *e* is the coupler-bar, which is affixed to a platform, *f*, which at *f*<sup>1</sup> is provided with a projecting rim,

while at *f*<sup>2</sup> it is connected to the reed board or frame *g* by means of a hinge, *h*, which is held correctly in position by a hinge-strip, *h'*, that also serves as a stop for the platform *f*, to prevent its being raised too high, and thereby getting out of place or damaging the hinge *h*. On its under side the coupler-bar *e* is provided with a series of gains or channels, *e'*, cut or formed at an angle, as shown. Within these gains or channels *e'* are supported the levers *c*, which, in the arrangement shown by Figs. 1, 2, 3, and 4, are kept in their proper position by means of screws or short axes *e*<sup>2</sup> passed through holes in the levers *c*, at right angles to the same, and held and supported by the sides of the gains or channels *e'*. *e*<sup>3</sup> are notches or recesses cut in the coupler-bar *e* for the purpose of allowing of the insertion of the screws or axes *e*<sup>2</sup>. The coupler-levers *c*, at their ends *c*<sup>2</sup>, are slightly bent upward, and formed with a suitable curve on their upper sides, so that they may be readily operated by the keys *a* when desired, while at their opposite ends *c*<sup>1</sup> they are bent upward, or provided with vertical projections *c*<sup>4</sup>, the upper surfaces of which are provided with suitable clothing *c*<sup>5</sup>, and are adapted to operate the ends *d*<sup>1</sup> of the levers *d*, the opposite ends of which are so arranged as to rest upon the buttons *b'* of the pitman *b*. The levers *d* are supported in gains or channels *e*<sup>4</sup>, formed in the upper surface of the coupler-bar *e* at a reverse angle to that of the gains or channels *e'*, as shown by Figs. 1, 3, and 4. The levers *d*, in this arrangement, are retained in position by means of screws or short axes *d*<sup>2</sup>, passing through holes in the levers *d* at right angles to the sides of the same, and held or supported by the sides of the gains or channels *e*<sup>4</sup>, as shown by Figs. 1 and 3. *e*<sup>5</sup> are notches or recesses to facilitate the insertion of the screws or axes *d*<sup>2</sup>.

The pitmen *b* are supported and guided at their upper ends by passing through openings *i* in the pitman-board *i*, which is usually attached to the under side of the key-frame, while at their lower ends the pitmen *b* are conducted down through the reed board or frame, so as to operate the valves *m*, which are kept up in position, as will be readily understood, by means of springs *n*, or other suit-

able mechanism. *j* is a slide operated by a stop, and arranged to move backward and forward, as desired, on pins or guides *j*<sup>1</sup>, passing up through slots *j*<sup>2</sup> in the slide *j*. The slide *j* is provided with a cam surface or groove, *j*<sup>3</sup>, so formed that, when the slide *j* is drawn backward or forward by its stop, it shall cause a pin or stud, *k*, affixed in the end or rim *f*<sup>1</sup> of the platform *f*, to raise or lower the front end *f*<sup>3</sup> thereof, and cause the platform *f* and coupler-bar *e* to turn on the hinge *h*, and tilt the coupler-bar *e* and levers *c*, so that they shall be brought into or out of position, so that the ends of the levers *c* may be operated by the keys *a*, and actuate the levers *d*. The levers *c d* are so arranged that the angle at which they are placed in respect of one another and the keys *a* is such that any pair of levers *c d* shall operate a pitman, *b*, exactly one octave from the pitman *b* operated by the key *a* for the time in action. They may, however, be arranged to couple at other intervals, if necessary. On their under side the keys *a* are provided with buttons or extensions *a*<sup>1</sup>, (one of which is shown separately at Fig. 5,) formed at one end with screws or pins *a*<sup>2</sup>, for the purpose of holding the buttons in position beneath the keys *a*, as shown by dotted lines in Fig. 1, while they are provided with suitable clothing *a*<sup>3</sup> at their opposite ends, which come in contact with the ends of the levers *c*.

Figs. 6 and 7 show a slight modification of the mode of pivoting the levers *c d* in their gains or channels in the bar *e*. In this case the levers *c d*, in place of being pivoted on separate short screws or axes, are pivoted on continuous rods or axes *o*, placed along the bar *e*, and resting in the saw cuts or grooves *o*<sup>1</sup>, while the levers *c d* are formed with notches or recesses *o*<sup>2</sup> to receive the rods *o*.

Although I have shown my improved coup-

ler-action attached to parts of a parlor or reed organ, it may readily be applied to other organs and similar keyed instruments, as will be readily understood by those acquainted with the manufacture of musical instruments.

Having thus described my invention, what I claim, and desire to secure by Letters Patent, is—

1. A coupler-bar, *e*, constructed with a double tier or series of gains or channels, *e*<sup>1</sup> *e*<sup>2</sup>, arranged at reverse angles to and one above the other, and adapted to receive and support the levers *c d*, substantially as shown and described.

2. The combination, with a coupler-bar, *e*, provided with a double tier or series of gains or channels, *e*<sup>1</sup> *e*<sup>2</sup>, arranged at reverse angles to and one above the other, of the levers *c d* and hinged platform *f*, substantially as shown and described.

3. An organ-coupler embodying in its construction a series of levers, *c d*, interspaced between the pitmen *b*, and supported at opposite angles, the one to the other, within a coupler-bar, *e*, having a double tier or series of gains or channels, *e*<sup>1</sup> *e*<sup>2</sup>, arranged at reverse angles to and one above the other, substantially as shown and described.

4. The combination, with the keys *a*, of the levers *c d*, coupler-bar *e*, gains *e*<sup>1</sup> *e*<sup>2</sup>, hinged platform *f*, pitmen *b*, and valves *m*, all constructed and arranged to operate substantially as shown and described.

In testimony that I claim the foregoing as my own I affix my signature in presence of two witnesses.

JOSEPH R. PERRY.

Witnesses:

C. L. BULKELEY,  
M. F. McCARG.