

A. V. S. SMITH.  
 Pocket Blank-Book.

No. 168,796.

Patented Oct. 11, 1875.

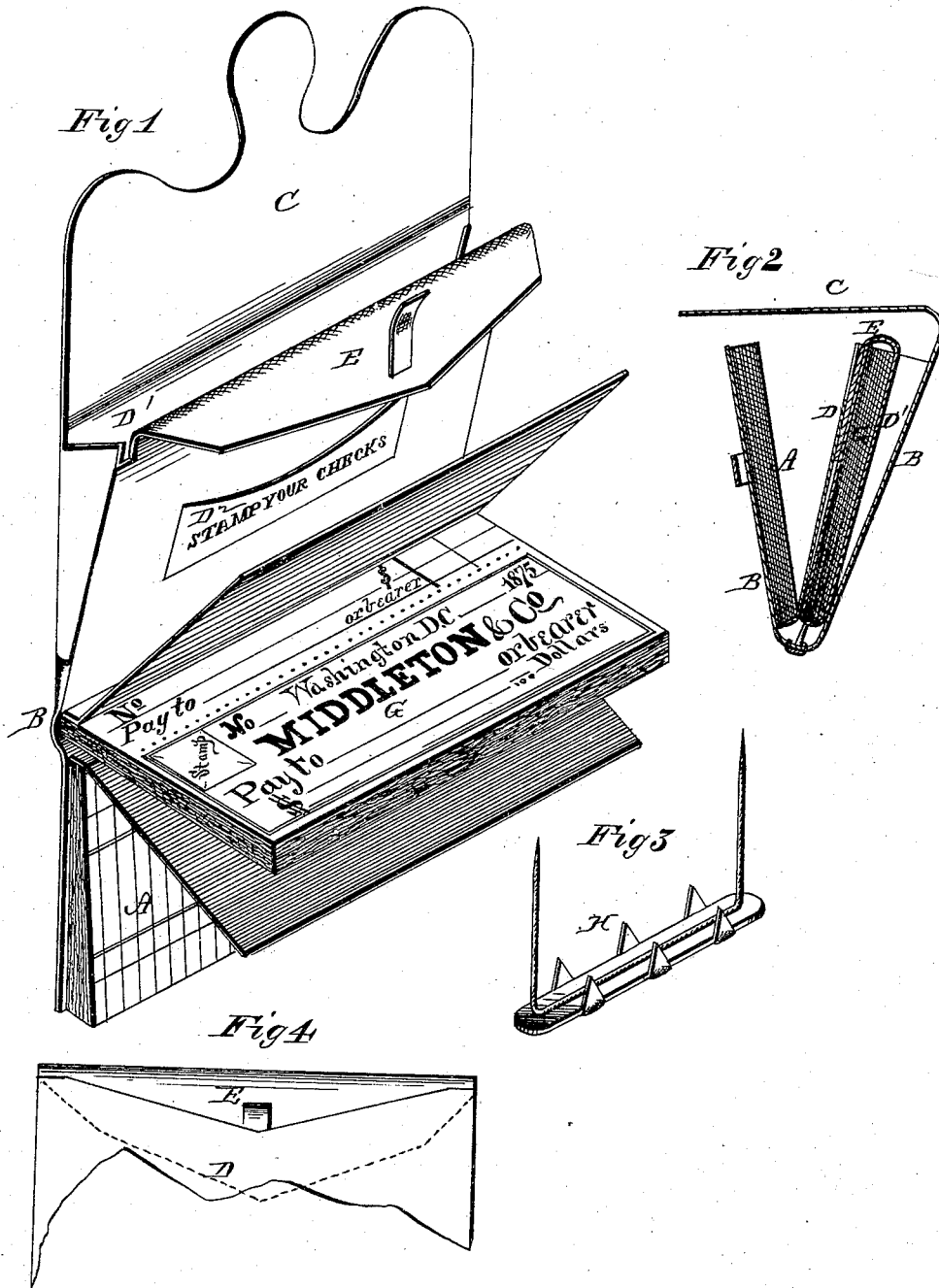

WITNESSES  
*Frank L. Overland*  
 By  
 C. L. Eversh.

INVENTOR  
*A. V. S. Smith*  
*Alexander D. ...*  
 Attorney

# UNITED STATES PATENT OFFICE.

ANDREW V. S. SMITH, OF WASHINGTON, DISTRICT OF COLUMBIA.

## IMPROVEMENT IN POCKET BLANK-BOOKS.

Specification forming part of Letters Patent No. **168,796**, dated October 11, 1875; application filed June 8, 1875.

*To all whom it may concern:*

Be it known that I, ANDREW V. S. SMITH, of Washington, in the county of Washington and in the District of Columbia, have invented certain new and useful Improvements in Combined Bank, Check, and Pocket Book; and do hereby declare that the following is a full, clear, and exact description thereof, reference being had to the accompanying drawings and to the letters of reference marked thereon, making a part of this specification.

The nature of my invention consists in a bank-book provided with a pocket containing a check-book detachably secured to the bank-book, as will be hereinafter more fully set forth.

In order to enable others skilled in the art to which my invention appertains to make and use the same, I will now proceed to describe its construction and operation, referring to the annexed drawing, in which—

Figure 1 is a perspective view of my combined bank and check book. Fig. 2 is a cross-section of the same. Fig. 3 is a perspective view of the device for fastening the check-book. Fig. 4 is a view of the pocket in my combined bank and check book.

A represents an ordinary bank-book, permanently attached to one side of the cover B, made of any suitable material, the other side of said cover being formed with a flap, C, to close over the outer edge of the book. The inner side of the bank-book A, which is not fastened to the cover B, is made of suitable thickness to form a pocket, D. In the loose part of the cover B is formed another pocket, D<sup>1</sup>, with a flap, E, as shown. In the space

left between the two pockets D and D<sup>1</sup> is placed a check-book, G, which is fastened to the back of the cover B by means of a fastener, H, constructed substantially as shown in Fig. 3, or in any other suitable or convenient manner.

The flap E is passed or laid over the outer edge of the check-book and inserted in the pocket D, thus concealing, as it were, the check-book, while allowing free access to the pocket D<sup>1</sup> when the bank-book is opened. On the pocket D<sup>1</sup> is a small pocket, D<sup>2</sup>, for revenue-stamps.

This device is convenient, as it combines in one book a bank-book, a check-book, and a pocket for deposit-slips, thus obviating the inconvenience of having the bank and check books separate. While making a deposit the check-book is concealed from view, and when all the checks have been used the stubs are easily detached and a new check-book inserted in its place.

Having thus fully described my invention, what I claim as new, and desire to secure by Letters Patent, is—

As an article of manufacture, the within-described bank and check book, consisting of the cover B, with flap C, the check-book G, bank-book A, pocket D, and flap E, all substantially as and for the purposes herein set forth.

In testimony that I claim the foregoing I have hereunto set my hand this 1st day of June, 1875:

A. V. S. SMITH.

Witnesses:

H. A. HALL,  
C. L. EVERT.