

E. SIRRET.
Muff Block Former.

No. 168,849.

Patented Oct. 19, 1875.

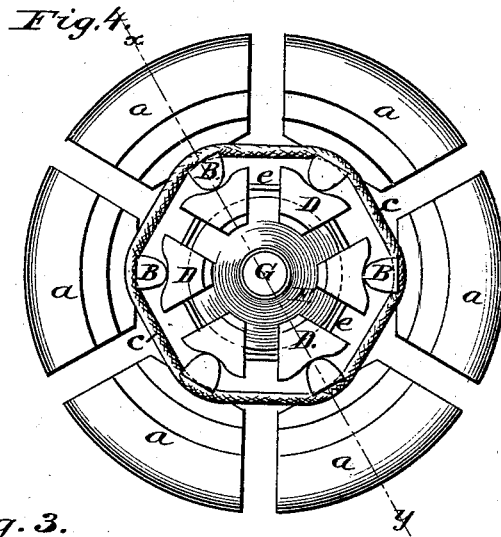
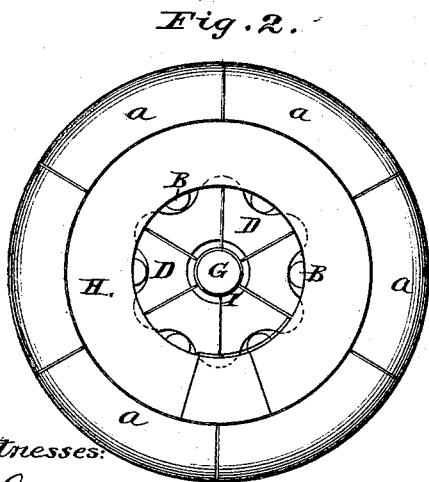
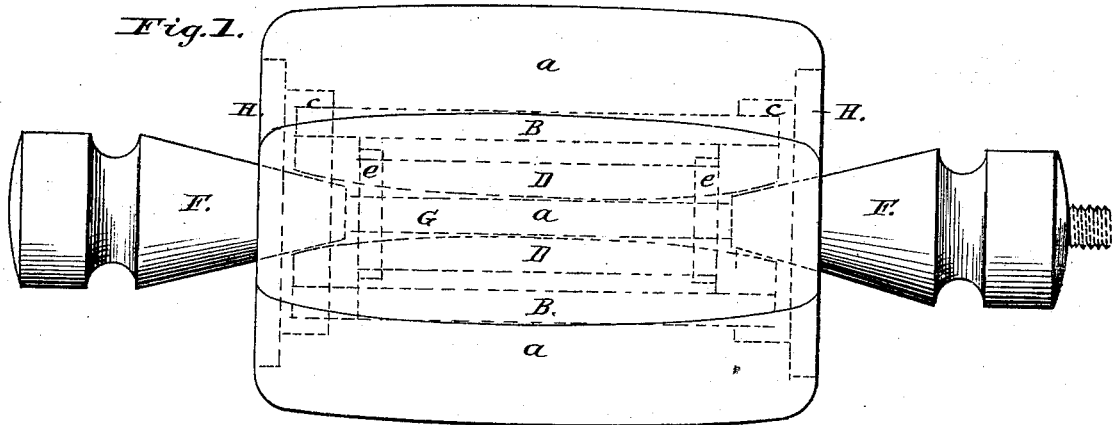

Witnesses:

Lawrence McDonald, Fig. 3.

Emile G. Sirret.

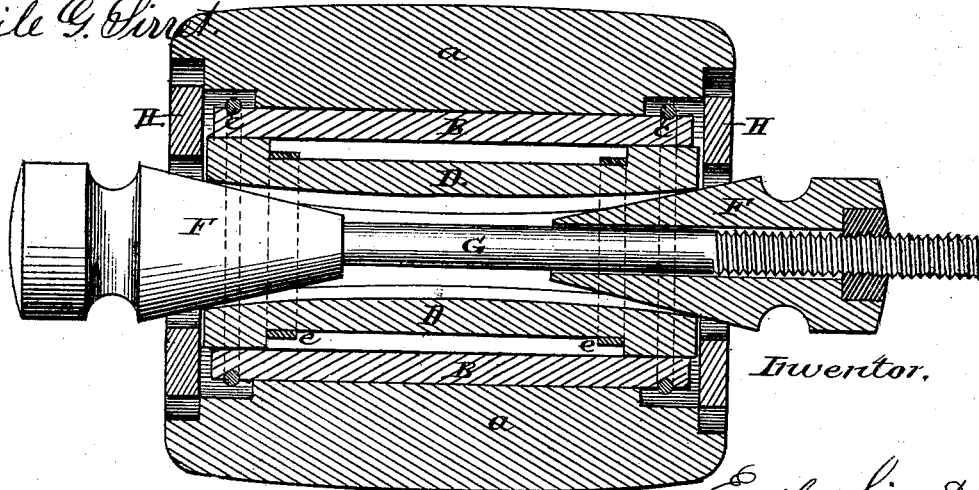

Inventor.

Emile Sirret.

UNITED STATES PATENT OFFICE.

EMILÉ SIRRET, OF BUFFALO, NEW YORK.

IMPROVEMENT IN MUFF-BLOCK FORMERS.

Specification forming part of Letters Patent No. **168,849**, dated October 19, 1875; application filed June 26, 1875.

To all whom it may concern:

Be it known that I, EMILÉ SIRRET, of the city of Buffalo, in the county of Erie and State of New York, have invented new and useful Improvements in Fur-Block Formers, which improvements are fully set forth in the following specification, reference being had to the accompanying drawing.

The object of my invention is to so construct and arrange the pieces composing a muff-block former that the same may, with greater facility, be inserted into and removed from a muff through the end openings; and, also, that either end of said muff may be expanded independently of the other, or the whole length evenly expanded, if desired, by means of a screw-rod and two conical handles.

Figure 1 is a plan view of my device, with internal parts dotted. Fig. 2 is an end view, with the end piece H on. Fig. 3 is a longitudinal section of the same when enlarged, and Fig. 4 is an end view when the end piece H is removed.

I construct my fur-block former of any desired size, by making six pieces out of wood, or any suitable material, of equal size, shape, and dimension, as shown in Figs. 2 and 4, and so that these six pieces will form the whole of the external shell of the block-former. These pieces *a* are held together by two india-rubber bands, *c*, placed in the interior of the block near each end. These bands *c* surround the extending ends of strips B, which are secured to the internal surface of piece *a*. Six other pieces, D, are held together by two elastic collars, *e*, making one piece, that I shall call the central part of the block, as shown by Figs. 1, 2, 3, 4. This central part has run through its central hole the screw-rod G, Figs. 1 and 3. Said hole is widened at both ends, so as to admit properly the introduction of

the conical part of the handle F F. Each of the pieces D composing the central part is provided with a shoulder or raised bearing at both ends, with grooves corresponding to the ends of strips B, upon which these bear, Figs. 3 and 4.

The operation of my invention is as follows: The block being compressed, the wetted skin is drawn over it and around the ends, and fastened to the end pieces H. The screw-rod is then run through the center of the block, and the loose handle screwed on at the ends. Both handles being turned to the right will cause said handles to move toward each other, and their conical parts to enter the block at each end and expand it. By resisting the entrance of the cone at one end, by placing the hand which holds the handle against the block, the opposite end alone will expand. By reversing the operation a contrary result is obtained. The whole length will expand evenly if both handles are turned equally. The skin having attained a proper and permanent shape, the block is then removed from the muff through the opening at each end—first the screw-rod G, then the end pieces H H, the central part D, the elastic bands *c c*, and the pieces *a*. When the elastic bands are off, the blocks may be easily readjusted to a muff already made and needing re-forming.

I claim—

The muff-former composed of the blocks *a*, having strips B, the blocks D, screw-rod G, and conical handles F F, all constructed, combined, and arranged to operate substantially as and for the purpose set forth.

EMILÉ SIRRET.

Witnesses:

GEO. G. NEWMAN,
EMILÉ G. SIRRET.