

# J. B. FULLER. Magneto-Electric Machine.

No. 168,893.

Patented Oct. 19, 1875.

FIG. 1.

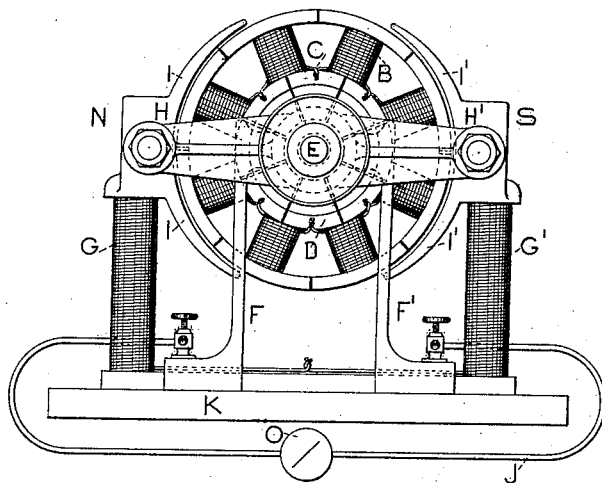

FIG. 2.

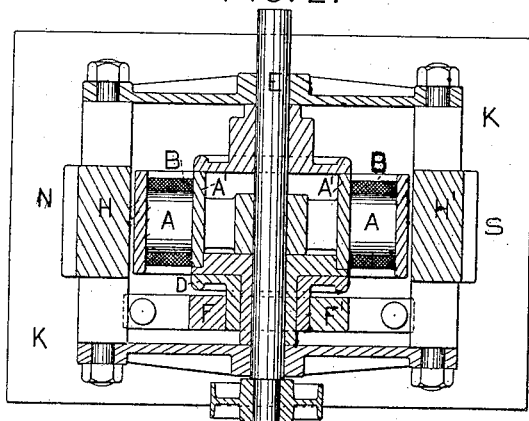

FIG. 3.

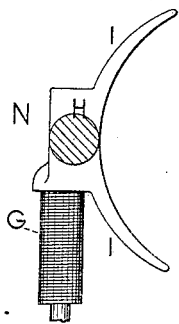
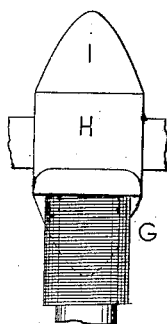

FIG. 4.



WITNESSES.

*Saml. F. Hay*  
*W. A. Goodchild*

*Jim. Billings, Fuller*

INVENTOR.

J. B. FULLER.  
Magneto-Electric Machine

No. 168,893.

Patented Oct. 19, 1875.

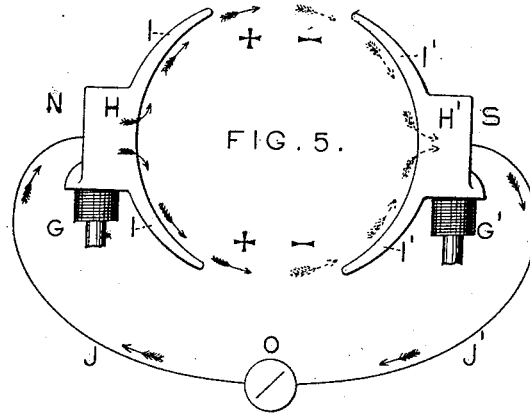

FIG. 6.

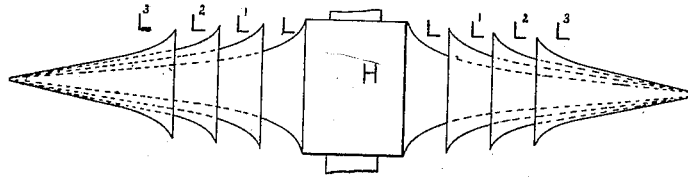

FIG. 7.

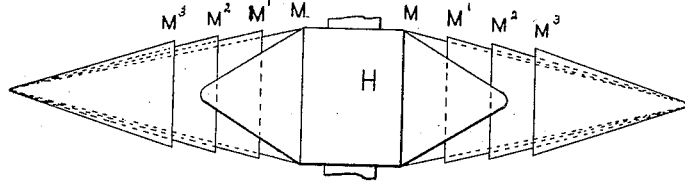
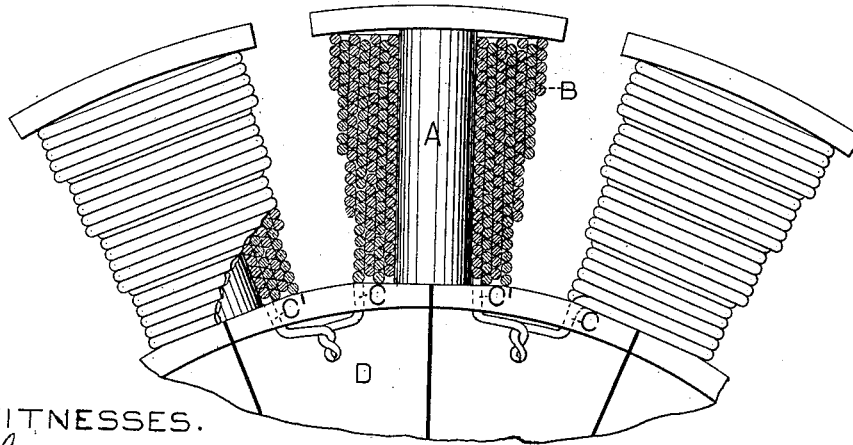

FIG. 8.



WITNESSES.

*Saml. F. Hay*  
*W. A. Goodchild.*

*J. B. Fuller*  
INVENTOR.

# UNITED STATES PATENT OFFICE.

JIM BILLINGS FULLER, OF BROOKLYN, NEW YORK.

## IMPROVEMENT IN MAGNETO-ELECTRIC MACHINES.

Specification forming part of Letters Patent No. **168,893**, dated October 19, 1875; application filed July 30, 1875.

*To all whom it may concern:*

Be it known that I, JIM BILLINGS FULLER, of Brooklyn, New York, have invented certain Improvements in Magneto-Electric Machines, which improvements are fully set forth in the following specification, reference being had to the accompanying drawings, in which similar letters indicate corresponding parts in each figure.

I am aware that induced electric currents have been generated in sectional coils of insulated wire surrounding a ring or cylinder of iron, and caused to revolve between magnetic poles, as described in Letters Patent No. 120,057; but it will be evident to those familiar with magneto-electricity that in a coil so constructed the magnetic lines of force operating upon said coil, inducing currents therein, will cause said currents, thus induced at the magnetic poles, to meet each other at points midway between said poles, where there is but little magnetic or electric effect.

My improvement consists in combining together the electric waves or impulses induced alternately in opposite directions in the armature of a magneto-electric machine, and forming them into constant currents flowing uniformly in one direction, by the employment of radial arms arranged around a shaft or cylinder and wound with coils of insulated wire, the ends of which are so joined as to form a series of connected radial electro-magnetic coils, communicating at proper points with corresponding parts of a sectional commutator, and caused to revolve between or near alternately-opposite magnetic poles, whereby said electric waves thus induced in the said coils are collected together in two equal electric currents of similar name, and caused to flow each in opposite directions from one of said poles, through all the intermediate coils, to a point in said wire nearest the next opposite pole, where said currents meet and combine, passing through an external circuit in one direction, and whereby said currents are also delivered at the points in the armature which, for the time being, are situated nearest the said magnetic poles, where the magnetic and electric energy is the strongest.

My improvement also consists in pointed or tapering or angular magnetic poles, as here-

inafter described, whereby the abrupt falling off of the magnetic force is prevented and the resulting current rendered more uniform.

A A represent several radial iron arms or cores arranged around and secured to the cylinder A' in any convenient manner, each being covered with a coil of insulated wire, B B. C represents the outer end of one coil, and C' the inner end of the next coil, these ends being joined together and connected to a section of the commutator D, as shown. This commutator is made, in any convenient form, into the number of sections corresponding to the number of radial arms, each section being insulated from the other, and also from the shaft and armature. E is the shaft, upon which the arms revolve in suitable bearings, and it may be provided with any convenient means for receiving rotary motion. F F' are metal springs, which bear on the commutator for conveying the currents through the external circuit J. G and G' are fixed magnets. H is the positive pole, and H' the negative. The magnetic poles are situated diametrically opposite each other. These poles are pointed or tapered toward the neutral point, as indicated by I I I'. K is the bed-plate on which the apparatus rests, being made of wood or other non-magnetic material.

Any desired number of arms may be employed, and may be placed in line with the shaft, or at any desired angle therefrom; and, although I prefer to set them radially, the outer ends may be inclined either forward or back.

Any number of fixed, permanent, or electro magnets may be used, and currents from a galvanic battery, from a magneto-electric machine, or a suitable number of coils from the above-described machine, may be employed for magnetizing the electro-magnets; or two coils may be placed on each arm, the outer coils connected to one commutator, and the inner coils connected to the other commutator. One set of coils may be employed for exciting the above-named fixed electro-magnets, while the other set send their currents through an external circuit, to be used as desired.

There should be as many commutator-springs for each commutator as there are

magnetic poles, and each spring should bear on the section of the commutator which, for the time being, communicates with the radial arms nearest the poles. Each set of springs will deliver separate currents, which may be used separately or together, as desired.

It is well known that magnetic force is weakened in proportion to the square of the distance from the poles; therefore, it will be seen that the tapering poles herein shown prevent this abrupt falling off of magnetic force, as applied to the revolving armature, and cause the electric waves to be gradually reduced on one side of the poles, and gradually increased on the other. The difference in the waves may be compared by reference to Fig. 6, corresponding with the straight pole, and Fig. 7, corresponding with the tapering one.

L and L', Figs. 1, 2, and 3, represent the electric waves formed from straight-faced magnetic poles. M and M', Figs. 1, 2, and 3, represent the waves as formed by the tapering poles, the latter, when lapped together, forming currents sufficiently uniform for all practical purposes.

I prefer to have these poles taper from both ends to a point at or near the center; but the taper may be all on one side, so that one end of the armature will leave the poles before the other end, and in that way gradually lose its magnetic influence; or the magnetic poles may be set at any angle from the axis-line which will produce the same effect.

In a machine used for telegraphic purposes, having several sets of magnets and springs, and consequently several complete circuits, each circuit may be employed separately for separate lines of telegraph; or several circuits may be combined together for long lines, and one circuit may be used, instead of a local battery, for operating the sounder while a number of circuits combined are working the main line.

The operation of this apparatus and the formation of currents therein are as follows: Each arm, in its revolution, receives increasing magnetic strength while passing from the neutral point to the most intense magnetic point in the poles; and this increase induces in the surrounding coil an electric wave of increasing intensity in one direction, dependent upon the direction of motion of the armature. Now, the instant the arm, in its revolution, passes by and moves away from this point, and its magnetic strength begins to decrease, this wave instantly breaks, and another wave of the same polarity, but in opposite direction, and at first of maximum intensity, is commenced in the coil, which intensity decreases as the arm approaches the next neutral point. The tendency of the two negative waves thus induced would be (the circuit being closed) to meet and oppose or neutralize each other; but as this meeting takes place under the commutator-springs, both waves, being of the same polarity, leave the coil and pass through the spring into the

external circuit. The tendency of the two positive waves would be to neutralize each other by separation; but, the spring acting upon two sections of the commutator at that point, and at the same moment, the said waves pass in opposite directions around the coils. At the neutral point a change in these waves thus formed takes place, not in direction, but from positive (+) to negative (-), and that change greatly intensifies the waves. Thus it will be seen that a current passing from the external circuit divides at the section of the commutator then nearest the north pole into two lesser currents, one of which passes to the right and the other to the left through all the intermediate connected coils, meeting again in the section of the commutators nearest the south pole, and combining in the external circuit in one current.

Fig. 5 represents the direction in which the currents flow while in the armature, and also through the external circuit. The whole arrows show the positive (+) and dotted arrows the negative (-) currents.

There are constantly one series of positive (+) and one series of negative (-) waves passing in the direction of rotation of the armature. There are also one series of positive (+) and one of negative (-) waves passing in the opposite direction; and these waves are the most energetic when the coils in which they are induced are nearest the poles.

While one positive (+) wave grows positively weaker as the coil in which it is induced is passing away from the north pole, another positive (+) wave will be growing positively stronger as the coil in which it is induced approaches the opposite side of the north pole. At the same time, while one negative (-) wave grows negatively weaker as the coil in which it is induced moves away from the south pole, another negative (-) wave will be growing negatively stronger as the coil in which it is induced approaches the opposite side of the south pole. Therefore, waves thus formed, flowing through the whole series of coils, and combined together in the external circuit, tend to give uniformity to the current.

It will be seen, also, that there will be many of these waves passing through the series at the same moment, each lapping over the next, and thereby giving additional uniformity to the current.

The magnetic poles tapering toward the neutral point prevent the strength of the waves from falling off abruptly, and equalize the strength of the resulting current.

The springs should be so set as to bear on at least two sections of the commutator at the same moment, so as to prevent any break in the current.

These machines may be employed for electroplating, electric light, or other industrial purpose, but are especially intended for producing currents uniform in quantity, inten-

sity, and constancy suitable for telegraph purposes.

I claim—

1. The combination of the arms *a*, the coils *b*, and the sectional commutator *d*, when the ends of the wire forming said coils are connected together, and to the commutator, substantially as set forth, said coils being caused to revolve between or near alternately opposite magnetic poles, developing electric waves or currents in said coils, and the currents developed being received and discharged con-

tinuously at the points in the wire forming said coils nearest said poles, or where the magnetic force is strongest.

2. The magnetic poles *h* and *h'*, having points or angles tapering toward the neutral magnetic point, substantially as and for the purpose specified.

JIM BILLINGS FULLER.

Witnesses:

MARTIN BAUER,  
PHILIP S. PENTZ.