

J. H. PLUMMER.
Scroll-Sawing Machine.

No. 168,920.

Patented Oct. 19, 1875.

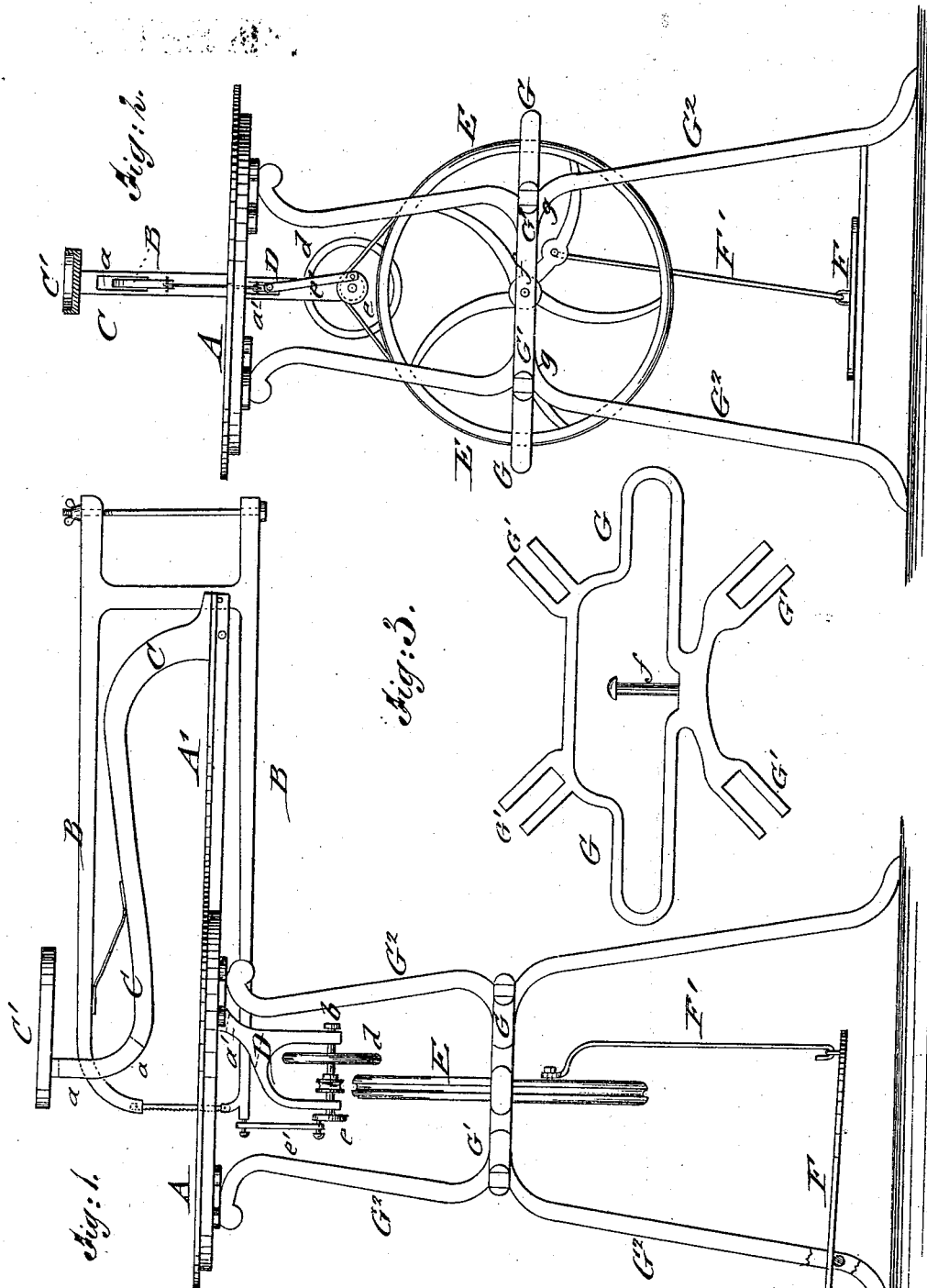

WITNESSES:

Chas. Nide
Alex F. Roberts

INVENTOR

J. H. Plummer

BY

Mum & Co

ATTORNEYS.

UNITED STATES PATENT OFFICE.

JEROME H. PLUMMER, OF BROOKLYN, NEW YORK.

IMPROVEMENT IN SCROLL-SAWING MACHINES.

Specification forming part of Letters Patent No. 168,920, dated October 19, 1875; application filed August 14, 1875.

To all whom it may concern:

Be it known that I, JEROME H. PLUMMER, of Brooklyn, in the county of Kings and State of New York, have invented an Improvement in Scroll-Sawing Machines, of which the following is a specification:

In the accompanying drawing, Figure 1 represents a side elevation of the machine; Fig. 2, a front elevation; and Fig. 3, a detail top view of the leg connecting frame.

Similar letters of reference indicate corresponding parts.

The invention will first be described in connection with drawing, and then pointed out in the claims.

In the drawing, A represents the table of my improved scroll-saw, which is made of suitable size and strength, and provided with a horizontal rear extension, A', to the rear end of which the reciprocating saw-frame B is pivoted. The saw-frame B is made of parallel arms with a lateral connecting-piece, one arm extending above, the other below, the table, both being provided with curved front ends of steel and with clamp-screws to hold the saw, that runs in a recess of table A. The rear ends of the arms of the saw-frame are provided with a connecting screw-rod for setting the saw taut in the frame. A curved arm, C, extends from the rear end of extension-arm A' to a point at suitable height above the center part of the same, and terminates in a small shelf, C', for the oiler's wrench, saw, &c., which is very convenient for the ready working of the apparatus. The top arm C has a slotted recess, a, at its front end, through which the upper arm of the saw-frame passes to be guided steadily thereby. A band-spring is interposed between the curved top arm C and the upper arm of the saw-frame to assist the upward motion of the frame and prevent the contact of the saw-frame with the upper end of the guide-recess. A curved arm, D, of shorter length than the top arm C is securely applied to the under side of the table, and provided below the point of connection with a similarly-slotted recess, a', for guiding the lower arm of saw-frame B. The bottom arm D is extended downward and forked in U-shape to support

the revolving shaft b of the motion-transmitting gear of the saw. Shaft b is rotated by pulley and belt connection with a large balance-wheel, E, that is again set in motion by a treadle, F, and connecting crank-rod F'. A small fly-wheel, d, of shaft b assists the motion of the latter, while a crank-disk, e, at the front end, and crank-rod e' form the connection with the front end of the lower arm of the saw-frame, and impart thereby reciprocating motion to the same. The balance-wheel E revolves on a stationary shaft, f, of a horizontal frame, G, that extends around the wheel, and forms, by forked or recessed socket-arms G¹, the connection with the table-supporting legs G. The legs G² are screwed rigidly, by flanged top ends, to the under side of the table A, and constructed, at the height of frame G, with inwardly-projecting lugs g, that are grooved at the sides and fitted into the socket-arms of the wheel-frame, so as to interlock firmly therewith and produce a rigid support of the table and operating mechanism. The treadle is hinged to a connecting-rod of the front legs and extended to such distance that the connecting crank-rod F' may be pivoted to the rear side of the same and swing freely in the wider part of the wheel-frame G.

A compact support and connection for the table, saw-frame, and operating parts are thus furnished, which admit the convenient shipping of the saw in detached parts, and its convenient putting together for use.

Having thus described my invention, I claim as new and desire to secure by Letters Patent—

1. A reciprocating saw-frame, B, combined with and pivoted to a table-extension, A', whose slotted arms C D form a guide thereto above and below the table, as and for the purpose set forth.
2. A rear table-extension, A', provided with a curved arm, C, supporting a shelf, C', as and for the purpose specified.

JEROME H. PLUMMER.

Witnesses:

PAUL GOSPEL,
T. B. MOSHER.