

L. K. SCOTFORD.  
Lathes for Turning Ovals.

No. 168,928.

Patented Oct. 19, 1875.

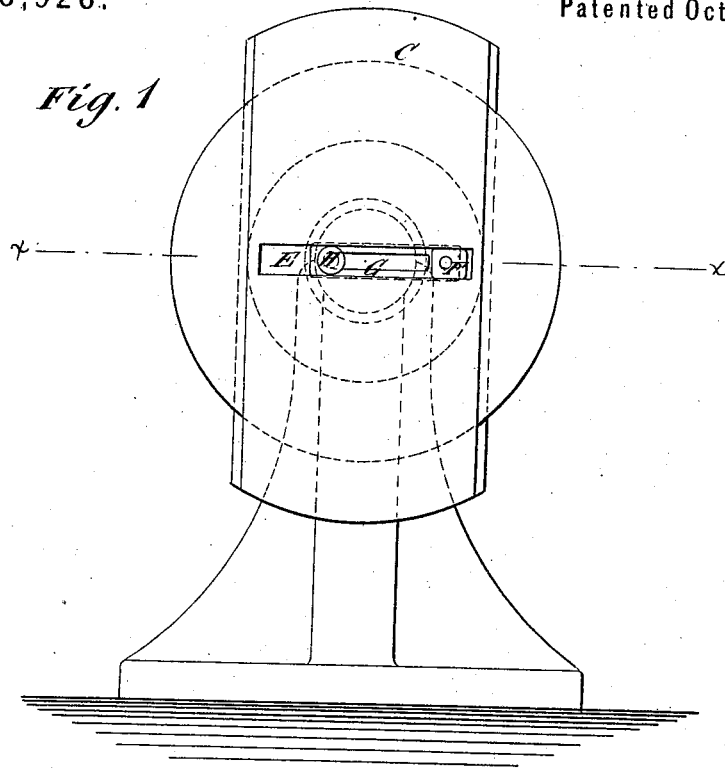

*Fig. 2*

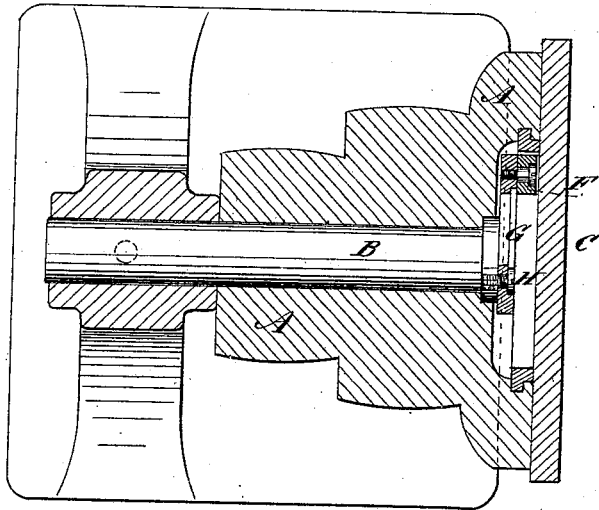

WITNESSES:

*C. Nevell*  
*A. J. Terry*

INVENTOR:

*L. K. Scotford*  
BY *Munnell*  
ATTORNEYS.

# UNITED STATES PATENT OFFICE.

LOUIS K. SCOTFORD, OF BURLINGAME, KANSAS.

## IMPROVEMENT IN LATHES FOR TURNING OVALS.

Specification forming part of Letters Patent No. **168,928**, dated October 19, 1875; application filed September 25, 1875.

*To all whom it may concern:*

Be it known that I, LOUIS K. SCOTFORD, of Burlingame, in the county of Osage and State of Kansas, have invented an Improvement in Lathes for Turning Ovals, of which the following is a specification:

My improvement consists of a sliding plate in the revolving disk having a slot, in which is a stationary stud, placed eccentrically to the axis of the disk, causing the slide to work forward and backward in the disk, the said stud being attached to a stationary center, around which the disk revolves, and being adjustable toward and from the axis of the disk to vary the movements of the slide, as required, for making ovals of different forms.

Figure 1 is a front elevation of my improved oval-turning lathe, and Fig. 2 is a horizontal section taken on line *xx* of Fig. 1.

Similar letters of reference indicate corresponding parts.

A A are the revolving cone-pulleys, turning on the stationary center B, and having the

face-plate C fitted in its face, so as to slide freely forward and backward. This slide, which is to carry the work, has a slot, E, which works on a stud, F, projecting from the stationary center B, and being attached thereto by the slotted arm G and bolt H, so that it can be shifted toward and from the axis. This causes the plate C to slide, more or less, according to the distance the stud is located from the center. The arrangement is a very simple one for oval-turning.

Having thus described my invention, I claim as new and desire to secure by Letters Patent—

The combination of the adjustable stud F with the stationary center B, rotating cone-pulleys A A, and sliding plate C, substantially in the manner described.

LOUIS K. SCOTFORD.

Witnesses:

S. D. WRIGHT,  
GEORGE W. DOTY.