

D. J. FARMER.

Machines for Drawing and Polishing Bars.

No. 168,975.

Patented Oct. 19, 1875.

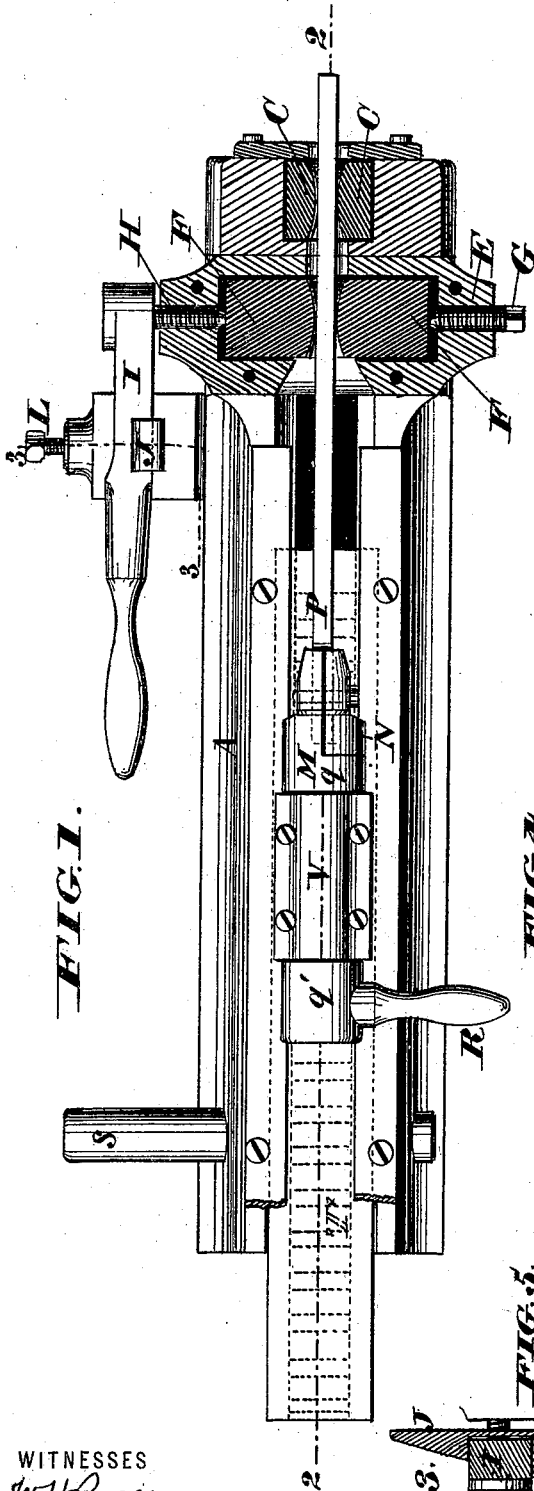

FIG. 1.

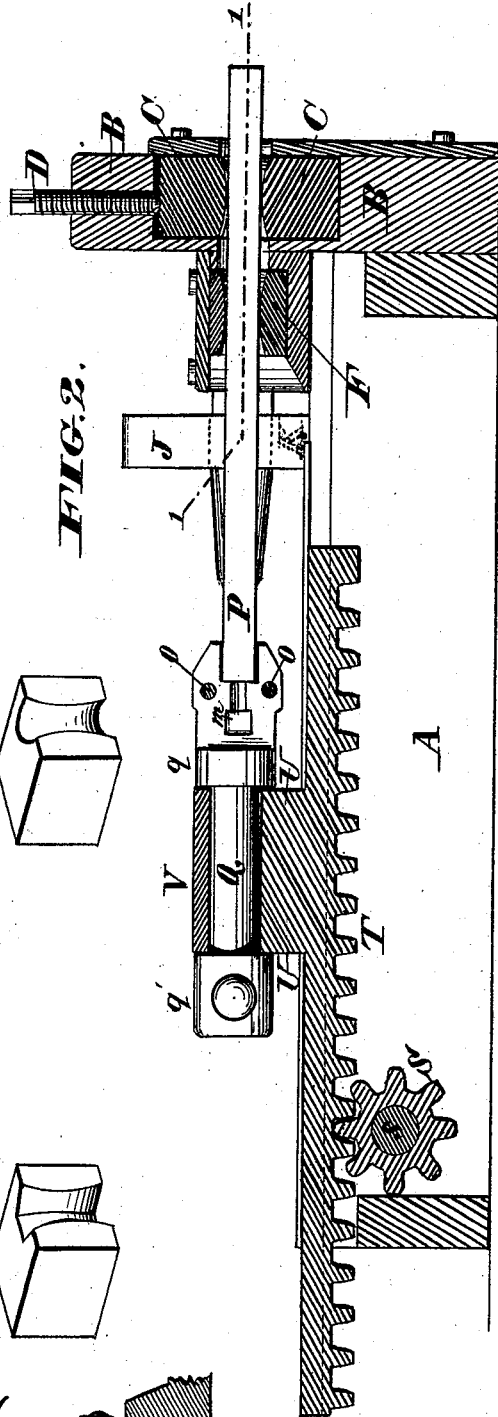

FIG. 2.



FIG. 3.

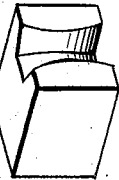

FIG. 4.



FIG. 5.

WITNESSES  
*W. H. Kearce*  
*Henry Tanner*

INVENTOR

*David J. Farmer.*  
 By *Knights* Attorneys

D. J. FARMER.

Machines for Drawing and Polishing Bars.

No. 168,975.

Patented Oct. 19, 1875.

FIG. 6.

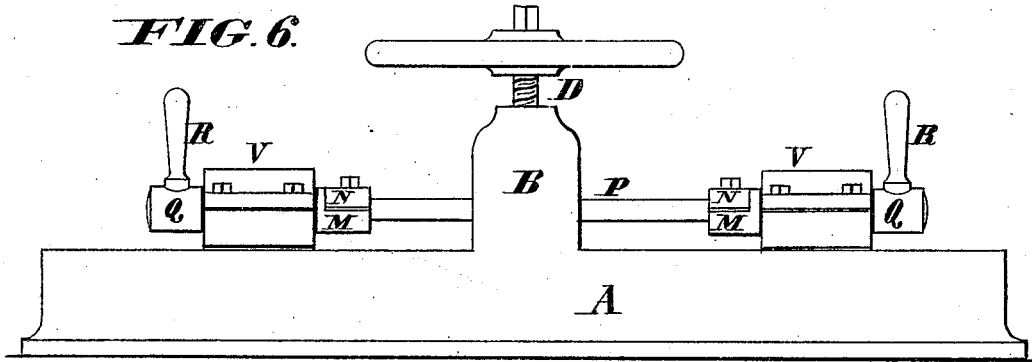

FIG. 8.

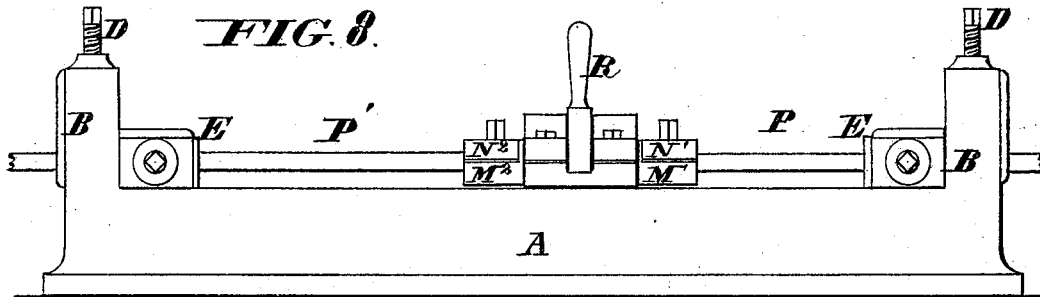
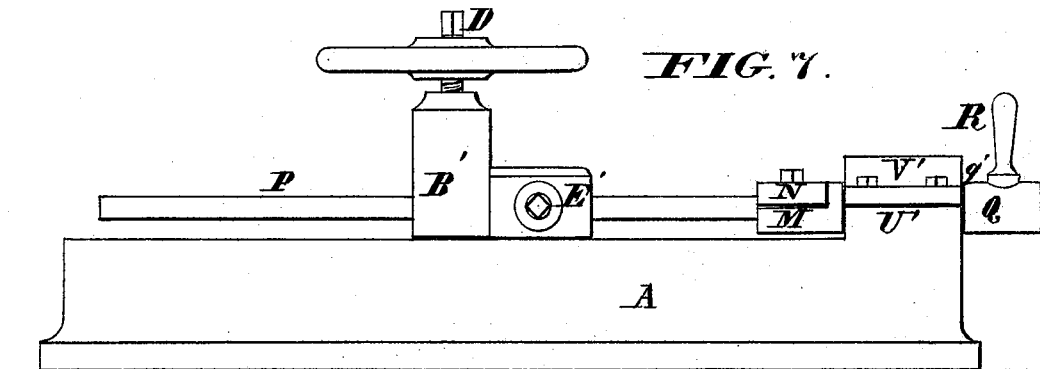

FIG. 7.



WITNESSES

*W. H. Pearce*  
*Henry Gannet*

INVENTOR

*David J. Farmer*  
*By Knight & Co. Attorneys*

# UNITED STATES PATENT OFFICE

DAVID J. FARMER, OF PENN YAN, NEW YORK.

## IMPROVEMENT IN MACHINES FOR DRAWING AND POLISHING BARS.

Specification forming part of Letters Patent No. **168,975**, dated October 19, 1875; application filed May 7, 1875.

*To all whom it may concern:*

Be it known that I, DAVID J. FARMER, of Penn Yan, in the county of Yates and State of New York, have invented a new and Improved Process and Apparatus for Condensing, Smoothing, and Polishing Metallic Bars or Plates, of which the following is a specification:

My invention consists, first, in providing a machine for drawing iron and steel bars with divided converging dies, constructed in such a manner as to be brought together by screws or equivalent means to a pressure, so as to reduce gradually iron and steel bars to any desired size, and finish them to a polish while being reduced. My invention consists, secondly, in providing a machine for drawing iron and steel bars with two or more adjustable converging dies, arranged one in advance of the other, and on opposite angles. My invention consists, thirdly, in combining in a machine for drawing iron and steel bars a base-frame, die-blocks, gripping-jaws, and intermediate die-blocks. My invention consists, fourthly, in combining in a machine for drawing iron and steel bars die-blocks, an operating-arm, and vertically-adjustable stock, carrying a spring-catch, for setting up the dies. My invention consists, fifthly, in providing a machine for drawing iron and steel bars with a box, holding-jaws of peculiar construction, having a journal and retaining collars, combined with suitable rotating and longitudinally-adjusting mechanism.

In the accompanying drawing, Figure 1 is a plan of an apparatus illustrating the invention, partly in horizontal section, in line 1, Fig. 2. Fig. 2 is a vertical longitudinal section on line 2, Fig. 1. Fig. 3 is a vertical transverse section of the peculiar die-adjusting mechanism on line 3, Fig. 1. Fig. 4 is a perspective view of one of the dies. Fig. 5 is a perspective view of another die. Figs. 6, 7, and 8 are elevations illustrating modifications hereinafter described.

A represents a bed-piece, to which are attached die-blocks B, holding dies C C, which are arranged in pairs, as shown, and are pressed together by set-screws D. E are die-blocks, holding dies F, which are adjusted by

set-screws G and H, the latter being fixed to an operating-arm, I, held down by a spring-catch, J, which is attached to a vertically-adjustable stock, K, fixed in any position to which it may be adjusted by a set-screw, L. The working faces of the dies C and F are formed, as illustrated in Figs. 4 and 5, so as to produce, when brought together, bell-shaped openings, flaring in each direction, and cause the dies to burnish and compress the bar or plate P, which is drawn through them. For the purpose of drawing the bar or plate it is gripped by one or more pairs of dies, M N, M representing the stationary jaw, and N the movable jaw, fixed thereto by screws O. The holder, made up of the jaws M N, is upon the end of a journal, Q, which may be rotated by an arm, R, so as to turn the bar or plate P on its axis, as required. The longitudinal movement of the holder *m* is imparted by a pinion, S, and rack T, to which rack is permanently fixed the box U, within which the receiving shaft or journal Q of the holder is held by a cap, V. Heads or collars *q q'*, at the extremities of the journal Q, confine the latter longitudinally within the box U.

The rotation of the bar between its passes through the dies is especially adapted for round or square bars, which may thus be treated effectively by means of a single pair of dies, a new surface being presented to the working faces of the dies at every pass.

The jaws M N are, preferably, constructed with a recess, *m*, at back, for the purpose of receiving a collar or flange, or projection of any form, which may be produced on the extremity of the bar to be drawn, by turning, hammering, or any means.

The object of this device is to enable the jaws more readily to hold the bar or plate under treatment without the possibility of its escape.

The pinion-shaft *s* will, in practice, be driven either by belt or gearing in connection with a fly-wheel, or by chain or screw gearing, or any suitable mechanical means which will give the requisite power.

The use of two pairs or sets of dies, as illustrated in Figs. 1 and 2, is advantageous in

treating bars of regular shape, as well as objects of irregular form. One pair or set of dies acts on the flat sides, while the other acts on the edges of the iron, so that the whole surface may be treated in a single pass.

The die is intended to be formed so as to burnish or polish and reduce the iron to the required size at the same time. If preferred, their flaring mouths or openings may be on one side only. For some purposes, dies may be used without the concave or excavated faces shown in this illustration.

The divided dies, arranged adjustably, form a most essential part of the improvement, together with the series of dies, one set being placed in advance of the other and arranged on an opposite angle, as shown.

The machine-bed is shown in Figs. 1 and 2, with die-blocks at its extreme end. It may, if preferred, be made of double length, with die-blocks B in the center, as illustrated in Fig. 6, and two sets of holders, M N, with their described accessories, to gripe the respective ends of the bar or plate under treatment. This modification permits the treatment of the bar or plate at both its back and forward stroke. The machine under this modification may have either one or more sets of die-blocks and dies.

If preferred, the holders M N, one or more, with their revolving heads or journals Q, may be held in boxes U', fixed permanently to the bed-plate A, as illustrated in Fig. 7, while the die-blocks B' E' are made to travel by the mechanism described, or any equivalent means, so as to act on the surfaces of a fixed plate or bar, P.

Fig. 8 illustrates another modification, in which die-blocks B E, with their accessories, already described, are applied to the respective extremities of the bed-plate A, and a double holder, M<sup>1</sup> N<sup>1</sup> M<sup>2</sup> N<sup>2</sup>, is employed for the purpose of treating two bars or plates, P P', at the same time. In this case either the dies and die-blocks or the holding-jaws may be arranged stationary or movable, as before stated.

The operation is as follows: The scale of the iron is first removed in the ordinary manner—that is, by any well-known means—and the end of the iron bar is prepared for the nippers or jaws, if found necessary. The iron bar is then placed in the machine, the dies drawn together, and the machine started, which draws the iron bar through the dies to its end, when the motion of the slide is reversed, and the iron bar brought back to its former position, the dies adjusted, and, when necessary, the jaw and bar are turned to a different angle, and again set in motion as before, and this is repeated until the iron bar is thoroughly polished and reduced to the proper size.

The advantages of the invention are as follows:

First, it is a simple and effective means of

polishing and smoothing the surfaces of bars and plates of iron or steel, without taking off the surface or injuring the fiber, and at a much less cost and manipulation than turning or planing, and is a more rapid and effective method than rolling.

Second, the iron bar being subject to a heavy tension by drawing through dies, and reduced at a heavy pressure, the fiber of the iron is drawn out and compressed, so as to bring it closer together, which gives solidity and a toughness to the iron, and adds much to its strength. In the turning or planing process the surface is necessarily taken off and the fiber injured, and thus the iron becomes weakened. In the rolling process the iron is not subject to a tensile strain, which I claim as an advantage. Where the iron is much reduced the rolling is more likely to crush the iron and make it hollow in reducing it cold.

Third, in drawing the bars through fixed or stationary dies, every inch of the bar or plate successively passes over the same surface of the die or dies, consequently a uniform evenness is produced with much less manipulation; whereas, in rolling, if either of the rolls should be left untrue in the turning, or should become so by use, the iron or metal run through the rolls would not be uniform. It would be smaller and larger alternately at each revolution of the rolls; and, further, if there are any soft places on the surfaces of the rolls, the pressure necessary in reducing the iron will cause indentations to form in the grooves, which produce prominences on the surface of the iron and make it very uneven; and there is generally more or less looseness in the bearings of the rolls, which allows the rolls to follow the soft places that are sometimes found in bars of iron and other metal, and thus produce an unevenness.

Fourth, the iron being subjected to a heavy tensile strain, it is given a severe test, so that any flaw or breach in the iron will cause the iron to separate, and the defect will thus be discovered. In the turning, planing, and rolling processes, the iron is not brought under tension, and a breach or flaw may be so covered by the process of smoothing as not to be detected until used.

Fifth, flat bars and angle iron, or bars of irregular and peculiar shapes, may be finished at the one process; whereas, in the rolling process, it has been the custom to plane the edges or sides where the rolls cannot be brought to act on the iron.

Sixth, the divided and adjustable dies reduce the iron or steel bars to any desired size, and produce a polished surface by pressure, caused by bringing the dies together similar to rolling, in the one or more sets of dies arranged at opposite angles, without changing the iron or steel bars to different-sized holes or dies.

The following is what I claim as new, and desire to secure by Letters Patent—

1. In a machine for drawing iron and steel bars, the divided converging dies, the parts of which are capable of being brought together by means of screws, as and for the purpose set forth.

2. In a machine for drawing bars of iron or steel, two or more adjustable converging dies, arranged one in advance of the other, and on opposite angles, as shown and described.

3. In a machine for drawing iron and steel bars, the combination of base-frame A, die-blocks B, griping-jaws M, and intermediate die-blocks E, as and for the purpose set forth.

4. In a machine for drawing iron and steel

bars, the combination of die-blocks E, operating-arm I, and vertically-adjustable stock K, carrying spring-catch J, as and for the purpose set forth.

5. In a machine for drawing iron and steel bars, the box U, jaws M N, having journal Q and collars *q q'*, in combination with suitable rotating and longitudinally-adjusting mechanism, as and for the purposes set forth.

DAVID J. FARMER.

Witnesses:

OCTAVIUS KNIGHT,  
CHAS. J. GOOCH.