

P. GIFFARD.
Air Spring for Car.

No. 168,980.

Patented Oct. 19. 1875.

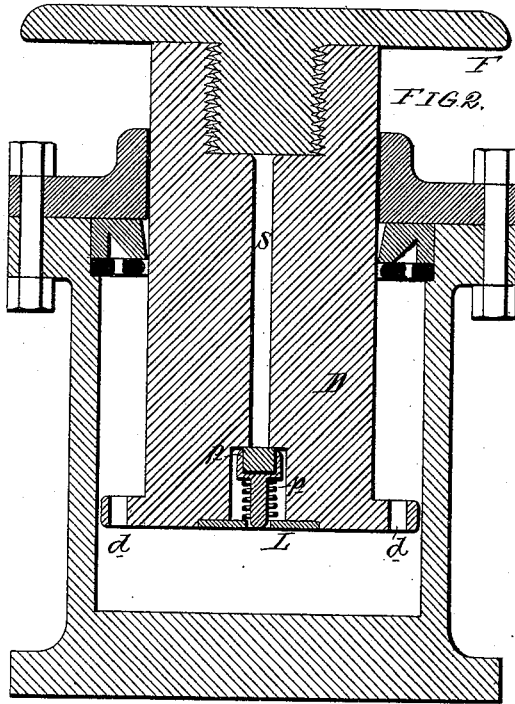
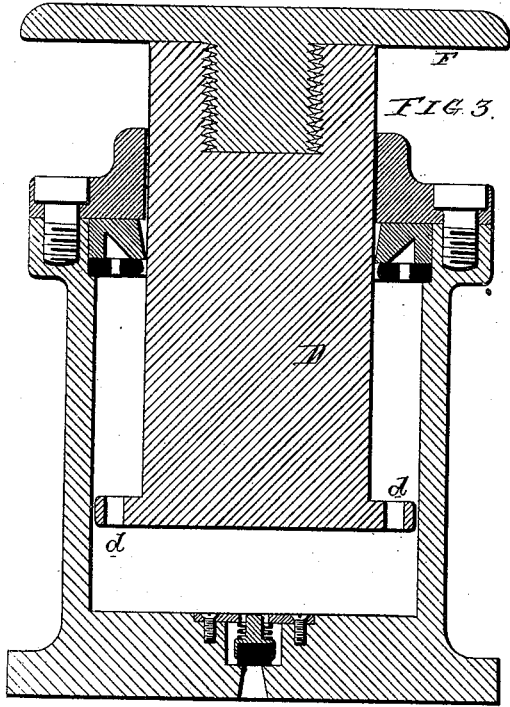

FIG. 1.

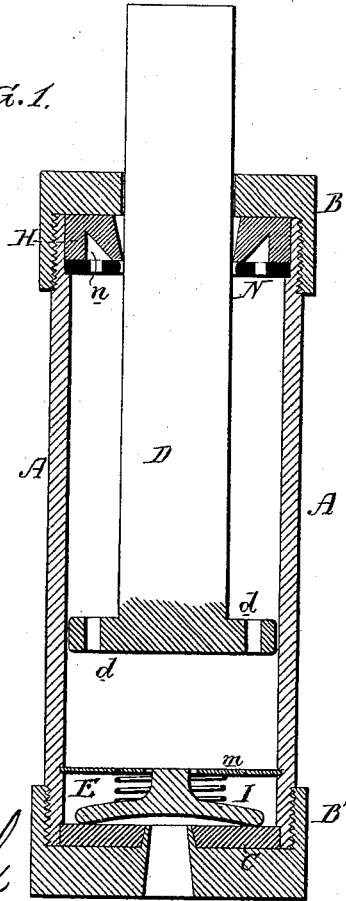
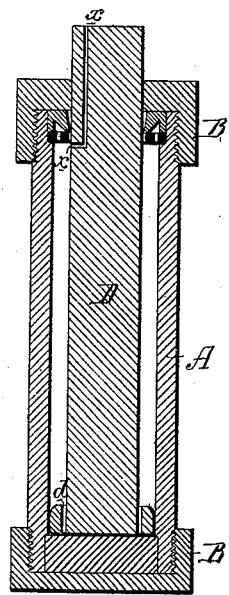

FIG. 4.



Witnesses,
Henry Smith
Hubert Howson

Paul Giffard
by his attorneys
Howson and Son.

UNITED STATES PATENT OFFICE.

PAUL GIFFARD, OF PARIS, FRANCE, ASSIGNOR TO CHARLES JAMES ADOLPH DICK, OF PHILADELPHIA, PENNSYLVANIA.

IMPROVEMENT IN AIR-SPRINGS FOR CARS.

Specification forming part of Letters Patent No. 168,980, dated October 19, 1875; application filed June 9, 1875.

To all whom it may concern:

Be it known that I, PAUL GIFFARD, of Paris, France, have invented certain Improvements in Air-Springs; and I do hereby declare the following to be a full and exact description of the same, reference being had to the accompanying drawing, in which—

Figures 1, 2, 3, and 4 represent vertical sections of my improved air-spring, the different views showing different modifications, but all containing the important feature of my invention.

In Fig. 1, A is a vessel, by preference of cylindrical form, and to the upper end of the vessel is secured a head, B, and to the lower end a base, B'. D is a plunger passing freely through and guided by the head B, and having at its lower end a perforated flange, *d*, the object of which is to aid the head B in steadying the said plunger laterally, so that it may always retain a position concentric with the vessel, the perforations in the flange *d* affording a free communication between the upper portion of the interior of the cylinder on one side of the flange and the lower portion on the opposite side. At a short distance from the upper edge of the vessel A, and within the same, is a ledge for supporting an annular perforated plate, N, and between the latter and the head B is confined a packing-ring, H, which I prefer to make of vulcanized rubber, the perforations in the said plate N permitting the free access of the compressed air in the cylinder to the packing. The opening in this packing-ring for receiving the plunger is largest in diameter above, and is tapered so as to bear at and near its lower edge only against the plunger. In the under side of the packing-ring is an annular recess, *n*, by preference of the angular shape shown, so that one side of the recess is vertical, or nearly so, and the other side inclined, the recess being directly above perforations in the plate N. Within the cylinder, and bearing on the base B', is a ring, C, of rubber, which serves the twofold purpose of packing for insuring a tight joint between the said base and cylinder, and of a seat for the valve E, between which and the plate *m* within the cylinder intervenes a spring, I, the latter tend-

ing to maintain the valve in contact with its seat on the ring. The device thus constructed is converted into a spring by charging it with compressed air or gases through an opening in the base by means of an air-pump or other suitable means. The gradual increase in the pressure of the spring can be regulated by varying the diameter of the plunger D in respect to that of the vessel and the amount of resistance by varying the pressure of air or gases in the cylinder A. The air in the vessel, being under constant pressure, must maintain the packing H in forcible contact with the said plunger, and keep the latter perfectly air-tight, and as the compression of the air increases the tighter will be the joint produced by this packing.

In Fig. 2 the spring is so constructed that the vessel can be charged with compressed air or gases through the plunger D, which is provided with a screw-cap, F, the removal of the latter exposing a central opening, S, which terminates below in a chamber, *p'*, containing a spring-valve, *p*, the stem of which is guided by a plate, L, secured to the bottom of the plunger, the valve closing the central opening S, excepting when compressed air or gas is being forced through the same into the vessel.

The modification shown in Fig. 3 is the same as that illustrated in Fig. 2, excepting that a foot-valve is arranged in the bottom of the vessel A.

The vessel may be charged with compressed air or gas without the aid of a foot-valve, and in the manner illustrated in Fig. 4, in which an opening, *x*, extends from the top of the plunger, first vertically and then laterally. When the plunger is depressed, as shown, this opening communicates with the interior of the vessel below the packing, and hence can be employed as a channel through which compressed air or gas can be forced into the said vessel; but as soon as the latter has been fully charged, and before the charging operation ceases, the plunger must be permitted to rise until the lateral position of its opening *x* is above the packing, when the avenue for the escape of compressed air or gas will be effectually closed, and will remain closed until the plunger is again so far depressed that the

lateral position of the opening x is below the packing. Washers of leather or other analogous substances impregnated with lubricating material may be advantageously employed above and below the packing; or, in order to insure a constant lubrication of the plunger, a supply of lubricant may be deposited in the interior of the vessel. This lubricant will find its way through the perforations of the guiding-flange d to the packing in the top of the vessel. Air-springs thus constructed may be used in different connections as substitutes for ordinary springs—for instance, the modifications shown in Figs. 2 and 3 are well adapted for use as railroad-car springs.

Two main features are essential in carrying out my invention: First, the spring should consist of a plunger and a vessel combined with a fixed packing confined to the vessel, in contradistinction to the combination of a packed piston with a vessel, for the latter will not admit of such easy construction of the spring to suit different degrees of resiliency or rigidity for different purposes as the use of a plunger in the manner described. Moreover, a perfectly-tight packing is more easily

insured and maintained when confined to the vessel, and combined with a plunger in the manner described, than when it is applied to a constantly-moving piston. The second important feature essential to my invention is the proper lateral steadying of the plunger, partly by the head of the vessel and partly by the guiding-flange d , for to permit the plunger to have any considerable lateral play might cause it to so act on the packing as to render the latter liable to leak.

I claim as my invention—

1. The recessed packing-ring H, confined to the vessel A, between the head B and annular perforated plate N, and adapted to the plunger, all substantially as set forth.
2. The combination of the plunger D and its perforated guiding-flange d with the vessel A and its packing.
3. The combination of the vessel A, plunger D, and opening x in the latter, for the purpose specified.

PAUL GIFFARD.

Witnesses:

DESBOIX,
Z. LEVERGEON.