

G. P. HARDING.  
Breech-Loading Ordnance.

No. 168,990.

Patented Oct. 19, 1875.

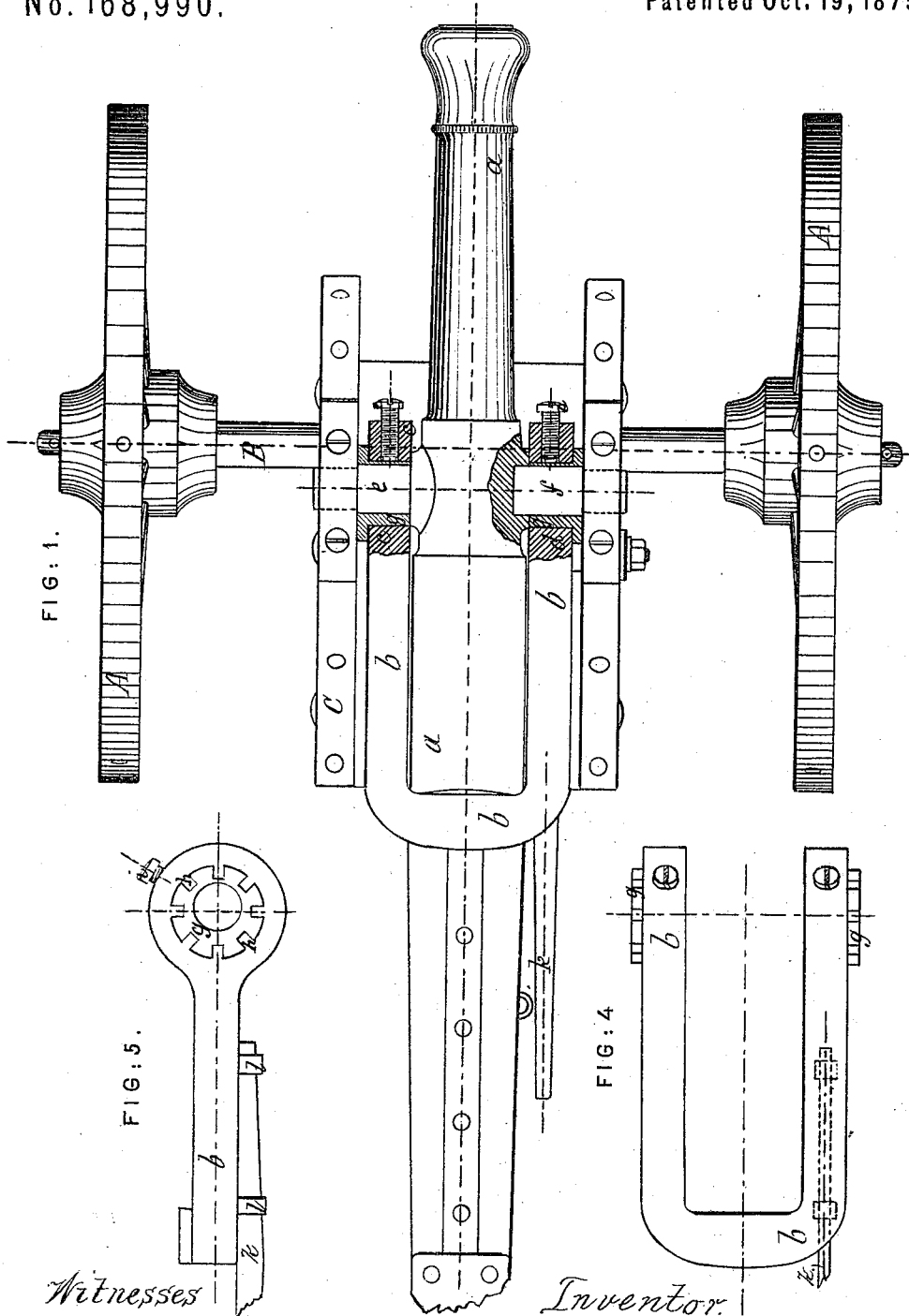

Witnesses  
 Geo. T. Smallwood, Jr.  
 John Robey Jr.

Inventor:  
 Gustavus P. Harding  
 By John J. Halsted  
 his Atty.

G. P. HARDING.  
Breech-Loading Ordnance.

No. 168,990.

Patented Oct. 19, 1875.

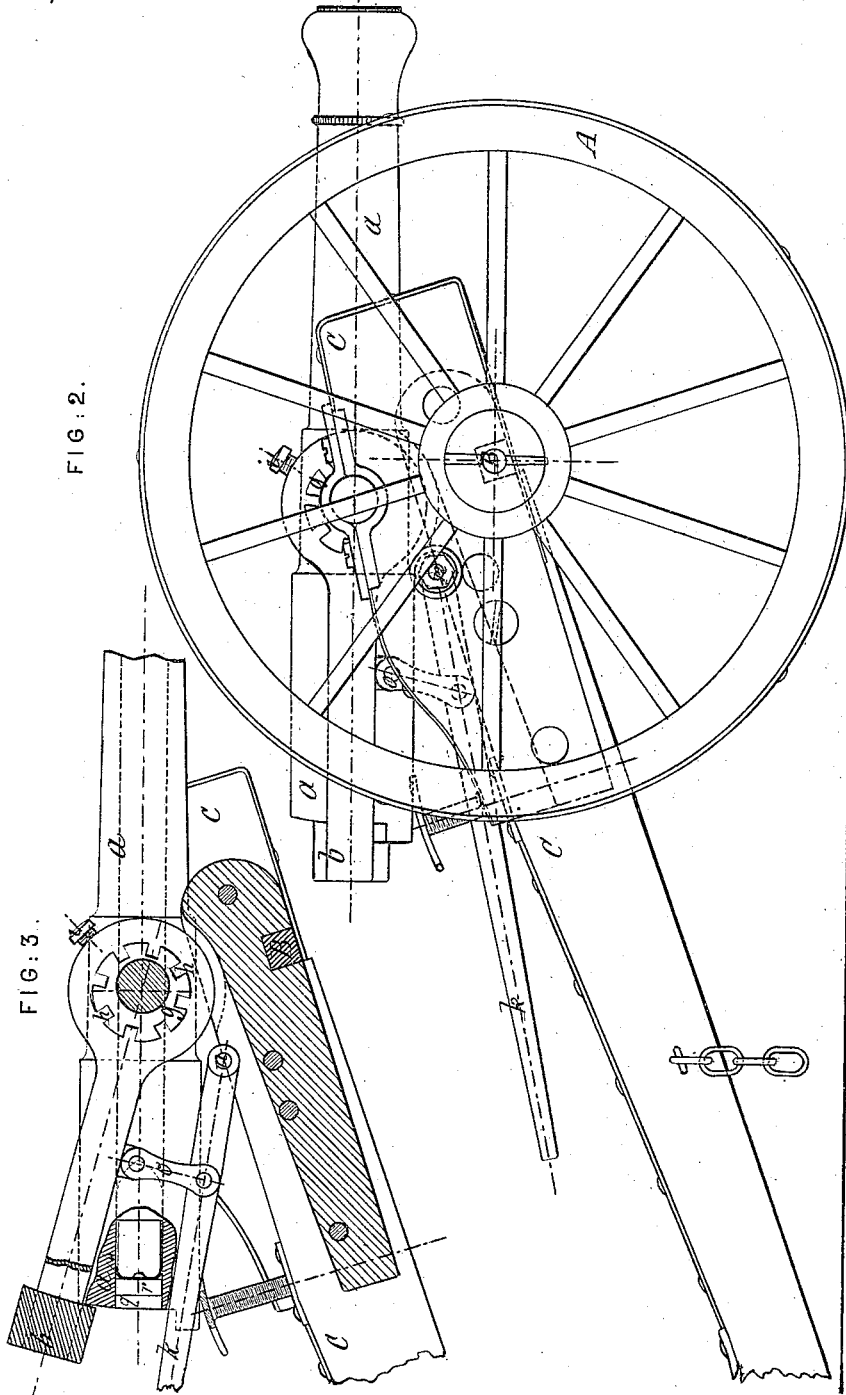

Witnesses.

Geo. T. Smallwood, Jr.  
John Robey Jr.

Inventor.

Gustavus P. Harding  
By John J. Halsted  
his Atty.

# UNITED STATES PATENT OFFICE.

GUSTAVUS P. HARDING, OF PARIS, FRANCE.

## IMPROVEMENT IN BREECH-LOADING ORDNANCE.

Specification forming part of Letters Patent No. 168,990, dated October 19, 1875; application filed August 27, 1875.

*To all whom it may concern:*

Be it known that I, GUSTAVUS PALMER HARDING, engineer, of No. 3 Rue du Helder, Paris, France, have invented certain new and useful Improvements in Breech-Loading Cannon; and I do hereby declare that the following is a full and exact description thereof, reference being made to the five figures of the two accompanying drawings, and to the letters of reference marked thereon.

These improvements relate to that class of cannon which are made in two parts—viz, a tubular part and a breech part, which forms the rear end of the cannon; and they consist in a special method of mounting the trunnions to compensate the elongation of the metal composing the breech-piece, consequent upon repeated percussions; in a special mode of adjusting the breech-piece by means of eccentric bushes; and in the devices for raising and lowering the breech-piece.

In order to compensate the elongation of the metal composing the breech-piece to which the repeated percussions of the powder may give rise, and to maintain the relative positions of the breech and the cannon, a metallic eccentric bush may be adapted round each trunnion of the cannon, and inserted in each eye of the breech, and, by the aid of a lever adapted to the said bush, it may be turned sufficiently to bring the breech in contact with the cannon. This arrangement is also advantageous to facilitate placing the breech-bar over the trunnions, for the diameter of the hole in the eye of the breech-bar, in which the eccentric bush is inserted, is sufficiently large for first passing the breech-bar on the trunnions, after which the eccentric bushes may be put in place.

The breech-bar may also be attached to the carriage instead of to the cannon, and in such case the cannon would not require trunnions, but merely slightly projecting rings cast with the central re-enforce of the same. Short cylindrical metallic blocks, of about the same diameter as the trunnions, would be placed in appropriate bearings adapted on either side of the carriage, and the extremities of these blocks facing the cannon would enter cavities bored for the purpose in the said dwarf trunnions. The breech-piece would, in this case,

be articulated on the short cylindrical blocks, and attached to the carriage in the same manner as when fixed to the trunnions of the carriage; but in such case the cannon itself must be firmly attached to the bottom of the carriage, so that it cannot be displaced by the force of the explosion or projected forward by the friction of the projectile in the case of rifled ordnance, while the tendency would be for the carriage to be driven back by the recoil. The cannon can also be attached to the carriage in such a manner that it can be brought nearer to or farther from the breech-piece in order to compensate the elongation or the contraction of the bar.

In order to prevent any escape of the gases at the moment of the explosion, at the place where the cannon and the above-described breech-piece unite I make use of an obturator or wad, in wood or other appropriate material, which I insert in the rear end of the cannon, with one end facing the charge and the other the breech-piece. On the front face of this wad may be attached a metallic disk, formed in such a manner that it will be distended or expanded by the explosion, and thus close the cannon hermetically at the breech; or to this said metallic disk may be substituted a metallic cartridge or a partially-metallic cartridge, producing the same result. The wad also serves to diminish considerably the force of the percussion of the powder on the breech. It prevents the contact and the instantaneous action of the explosion on the breech-bar, and diminishes the recoil.

Having thus explained my improvements in general terms, I will describe them more amply in a practical point of view, conjointly with the five figures of the two sheets of drawing hereto annexed, of which—

Figure 1 is a plan of a field-piece constructed according to my new system; Fig. 2, a longitudinal elevation of the same; Fig. 3, a longitudinal elevation, in section, of the cannon and of a part of the carriage; Fig. 4, a plan of the breech detached; and Fig. 5, a longitudinal elevation of the same.

In these figures, A A represent the wheels, B the axle, and C the carriage, of an ordinary field-piece, to which I have adapted my new system of cannon *a*, consisting in a metallic

tube, open at its two ends, and a breech, *b*, in the form of a stirrup, the two arms of which are, at their extremities, provided with eyes *c* *d*, containing eccentric bushes *g g*. The one, *c*, represents my system of articulating the breech to the trunnion of the cannon. This trunnion *e* is made of two different diameters, the largest of which is inserted in the eye *c* of the breech, while the smaller one rests on the carriage *C*. The one, *d*, represents my system of breech articulated to the carriage *C* by means of a strong stud, *f*, having also two diameters, the largest of which is passed in the hole of *d*, and partly in a small recess formed in the dwarf trunnion of the cannon, while the smaller one rests on the carriage. *g g* are the eccentric bushes mounted in the holes *c d*. A maximum eccentricity of about one-eighth of an inch is sufficient for the adjustment of the breech to the cannon in a field-piece of the caliber indicated. To set the breech-piece by means of these bushes I make use of a toothed wrench, adapted in notches *h* cut out in the flanges of the said eccentric bushes, and after such adjustment I fix them by means of the screw *i*; and in order to maintain the parallelism of these two eccentrics I trace, if required, on the two external faces of the arms *c* and *d* circular scales, with which are made to correspond similar scales engraved on the flanges of the eccentrics.

At Fig. 3 I have indicated the breech-piece lifted for charging, and in Figs. 1 and 2 its position during the explosion. The motion to be imparted to this breech-piece is, as may be seen, very slight, and might be, if required, effected easily by hand, for field-pieces, by means of a movable lever, *k*, inserted in the eyes *l l* adapted underneath one of the arms of the breech-piece. (See Fig. 5.) However, to facilitate this action, especially for pieces of heavier caliber, I prefer making use of a lever, *k*, jointed to the carriage at *n*, (see Figs. 1, 2, and 3,) and connected, by a link, *o*, to the under part of the breech, and by these devices the breech-piece may be readily and positively raised or lowered relatively to the gun without disturbing or altering the position of the latter; as the lever, its link, and its fulcrum-bearing have no direct connection

with the gun, and the lever has to overcome the weight of the breech-piece alone.

My obturator consists in a disk of wood, *r*, or any other appropriate material, inserted in the rear end of the cannon, preferably at a slight distance from the breech-piece *b*, so as to form a small air-chamber, *g*, and provided on its front face with a metallic disk, *s*, with a small flange turned up at right angles to fit the bore of the gun, as shown, in such a manner that it is distended or expanded by the explosion, and thus closes the cannon hermetically at the breech. This kind of obturator also serves to diminish considerably the force of the percussion of the powder on the breech. It also prevents the contact and the instantaneous action of the explosion on the breech-bar, and diminishes the recoil. The disk of wood *r*, without the metallic disk *s*, employed conjointly with a metallic cartridge or a partially-metallic cartridge, will also produce similar results.

Having thus described the nature of my improvements, as also the best means that I am acquainted with for putting the same into practice, I do not restrict myself to the exact details above described and illustrated on the accompanying sheets of drawing.

I claim as my invention—

1. The described method of mounting the trunnions of cannon, consisting in making them of two diameters, and inserting the larger diameter in a bush in the eye of the breech, and resting the smaller diameter on its bearing on the carriage.

2. The described mode of adjusting the breech-piece by means of the eccentric bushes *g*, constructed, applied, and operated as described.

3. The combination, with the breech-piece, of the lever *k*, pivoted at its forward end to the carriage at *n*, and connected, by a rigid link, *o*, to the under part of the breech-piece, as and for the purpose set forth.

GUSTAVUS PALMER HARDING.

Witnesses:

P. PARBURY,

13 Rue Gaillon.

ROBT. M. HOOPER.